

Filters And Strainers

INLINE AND SIDE ENTRY



Provided by:

Holland[®]
APPLIED TECHNOLOGIES

www.hollandapt.com

Phone: 800-800-8464

ISO 9001
CERTIFIED

➤ **Waukesha Cherry-Burrell**[®]

These filter and strainer types are designed primarily for removal of particles of various sizes from a product. They are not intended to remove odors or impurities. Capabilities vary according to line pressure, size and amount of particles in product, etc.

Be sure to protect unit from damage when used with high speed or positive pump by using bypass or pressure relief system.

SPX FLOW, Inc. (NYSE:FLOW) is a leading manufacturer of innovative flow technologies, many of which help define the industry standard in the market segments they serve. From its headquarters in Charlotte, North Carolina, it operates a sales and support network, centers of manufacturing excellence, and advanced engineering facilities, throughout the world. Its cutting-edge flow components and process equipment portfolio includes a wide range of pumps, valves, heat exchangers, mixers, homogenizers, separators, filters, UHT, and drying technology that meet many application needs. Its expert engineering capability also makes it a premium supplier of customized solutions and complete, turn-key packages to meet the most exacting of installation demands.

Incorporating many leading brands, SPX FLOW has a long history of serving the food and beverage, power and energy, and industrial market sectors. Its designs and engineered solutions help customers drive efficiency and productivity, increase quality and reliability, and meet the latest regulatory demands. In-depth understanding of applications and processes, state-of-the-art Innovation Centers, and advanced pilot/testing technology further assist in optimizing processes and reducing timescales to reliably meet production targets.

To learn more about SPX FLOW capabilities, its latest technology innovations and complete service offerings, please visit www.spxflow.com.

Inline and Side Entry Filters and Strainers

PRODUCT FEATURES AND BENEFITS:

Waukesha Cherry-Burrell® stainless steel filters and strainers offer: sanitary, efficient flow design; flexibility in installation; and quick and simple cleanup. Strainers and filters are available in 316 or 316L stainless steel.

Filters provide a reliable means of removing fine particles from liquids. Filtering media must be removed and disposed periodically. Strainers, on the other hand, are coarse filters that remove larger particles. The straining mesh can be reused after cleaning.



Inline Strainers
1" (25 mm) through
3" (76 mm)



Side Entry Strainers
1" (25 mm) through
4" (76 mm)

DIMENSIONS:

| | Inches (mm) | SHORT | | | LONG | | | |
|---------------------------|----------------|----------------|----------------|----------------|----------------|----------------|----------------|---------------|
| | | A | B | C | A | B | C | D |
| BUTT WELD / S-LINE | 1.00 (25) | 15.75 (400) | 14.22 (361) | 12.41 (315) | 35.37 (898) | 33.81 (858) | 32.00 (812) | 3.50 (88) |
| | 1.50 (38) | 15.75 (400) | 14.22 (361) | 12.16 (309) | 35.37 (898) | 33.81 (858) | 31.75 (806) | 3.50 (88) |
| | 2.00 (50) | 15.75 (400) | 14.22 (361) | 11.91 (303) | 35.37 (898) | 33.81 (858) | 31.50 (800) | 3.50 (88) |
| | 2.50 (63) | 15.75 (400) | 14.22 (361) | 11.66 (296) | 35.37 (898) | 33.81 (858) | 31.25 (793) | 3.50 (88) |
| | 3.00 (76) | 15.75 (400) | 14.22 (361) | 11.41 (290) | 35.37 (898) | 33.81 (858) | 31.00 (787) | 3.50 (88) |
| | 4.00 (101) | N/A | 14.22 (361) | 10.91 (277) | N/A | 33.81 (858) | 30.50 (774) | 3.50 (88) |
| BEVEL | 1.00 (25) | 16.18 (410) | 14.47 (368) | 12.66 (322) | 35.81 (909) | 34.06 (865) | 32.25 (819) | 3.75 (95) |
| | 1.50 (38) | 16.31 (414) | 14.60 (371) | 12.53 (319) | 35.93 (912) | 34.18 (868) | 32.12 (815) | 3.87 (98) |
| | 2.00 (50) | 16.34 (415) | 14.60 (371) | 12.28 (311) | 35.97 (914) | 34.18 (868) | 31.87 (809) | 3.87 (98) |
| | 2.50 (63) | 16.72 (425) | 14.84 (377) | 12.28 (311) | 36.34 (923) | 34.43 (874) | 31.87 (809) | 4.12 (104) |
| | 3.00 (76) | 17 (431) | 14.84 (377) | 12.03 (304) | 36.62 (930) | 34.43 (874) | 31.62 (803) | 4.12 (104) |
| | 4.00 (101) | N/A | 14.84 (377) | 11.53 (292) | N/A | 34.43 (874) | 31.12 (790) | 4.12 (104) |
| FEMALE I | 1.00 (25) | 16.56 (420) | 14.84 (384) | 13.03 (331) | 36.18 (918) | 34.44 (874) | 32.63 (829) | 4.13 (105) |
| | 1.50 (38) | 16.78 (426) | 15.12 (376) | 13.06 (331) | 36.41 (925) | 34.71 (881) | 32.66 (829) | 4.41 (112) |
| | 2.00 (50) | 17.20 (436) | 15.40 (391) | 13.09 (332) | 36.78 (934) | 35.00 (889) | 32.69 (830) | 4.69 (119) |
| | 2.50 (63) | 17.46 (444) | 15.59 (395) | 13.03 (331) | 37.09 (942) | 35.19 (894) | 32.63 (829) | 4.88 (124) |
| | 3.00 (76) | 18.87 (479) | 15.78 (400) | 12.97 (329) | 38.50 (977) | 35.37 (898) | 32.56 (827) | 5.06 (129) |
| | 4.00 (101) | N/A | 16.09 (409) | 12.78 (324) | N/A | 35.69 (906) | 32.38 (822) | 5.38 (137) |
| MALE I | 1.00 (25) | 16.17 (411) | 14.65 (372) | 12.84 (326) | 36.80 (934) | 33.87 (860) | 32.44 (824) | 3.94 (100) |
| | 1.50 (38) | 16.39 (416) | 14.94 (379) | 12.87 (327) | 36.02 (915) | 34.00 (863) | 32.47 (824) | 4.22 (107) |
| | 2.00 (50) | 16.66 (423) | 15.16 (385) | 12.84 (326) | 36.26 (921) | 33.93 (861) | 32.44 (824) | 4.44 (113) |
| | 2.50 (63) | 16.84 (427) | 15.28 (388) | 12.71 (323) | 36.47 (926) | 34.12 (866) | 32.31 (821) | 4.57 (116) |
| | 3.00 (76) | 18.25 (464) | 15.47 (393) | 12.65 (321) | 37.88 (962) | 34.12 (866) | 32.25 (819) | 4.75 (121) |
| | 4.00 (101) | N/A | 15.78 (401) | 12.47 (317) | N/A | 34.12 (866) | 32.06 (814) | 5.06 (128) |

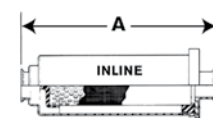
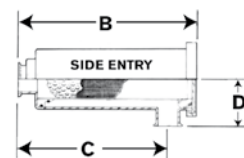

Dimensions are measured from this step



HOW TO BUILD YOUR PART NUMBER:

For ease in ordering, please see the features and options below to select the filter or strainer that fits your needs. Go on-line to our eSales website and order your filter or strainer using the options you selected.

1. Style:

- In-Line
- Side Entry

2. Size:

- Long
- Short

3. Line Size:

- 1" (25mm)
- 1.5" (38 mm)
- 2" (50 mm)
- 2.5" (63 mm)
- 3" (76 mm)

4. Back Up Tube:

- 1/4" (6.35mm) Holes
- 1/8" (3.17mm) Holes
- 1/4" (6.35mm) Holes HD
- None

5. Port Inlet:

- S-Line (S)
- Weld (W)
- Bevel Seat (B)
- Female I-Line (I)
- Male I-Line (MI)
- Q-Line (Q)
- SMS (SMS)
- Din (Din)

6. Port Outlet:

- S-Line (S)
- Weld (W)
- Bevel Seat (B)
- Female I-Line (I)
- Male I-Line (MI)
- Q-Line (Q)
- SMS (SMS)
- Din (Din)

7. Overscreen:

- Cotton (300 Micron)
- Nylon (800 Micron)
- Rayon (25-30 Micron)
- S.S. mesh (6, 8, 10, 12,16, 20, 24, 30, 40, 50, 60, 80, 100, 150, 200, 325)
- None

8. Elastomer:

- Buna
- FKM
- Silicone
- EPDM
- EPDM SF

9. Tags:

- None
- Stainless Steel Tags
- Paper Tags

Typical product applications

Food

- Baby Foods, Soups, Stews
- Tomato Paste
- Fruit Puree
- Vegetables, Diced, Slurries
- Puddings, Jams, Jellies
- Salad Dressings, Mayonnaise



Beverage

- Beer, Wort, Yeast
- Soft Drinks
- Fruit Concentrates
- Fruit Drinks



REPLACEMENT PARTS - HOW TO ORDER:

Part Numbers for Clamp Type and Buna (N):

- For Bevel Connections – Add "T" to Part No. i.e. 129-431TX
- For Female Connections – Add "F" to Part No. i.e. 129-431FX
- For Male Connections – Add "M" to Part No. i.e. 129-431MX
- For Seals & O-Rings in Viton – Add "V" to Part No. i.e. 20-89V
- For Seals & O-Rings in EPDM – Add "E" to Part No. i.e. 20-89E
- For Seals & O-Rings in Silicone – Add "S" to Part No. i.e. 20-89S

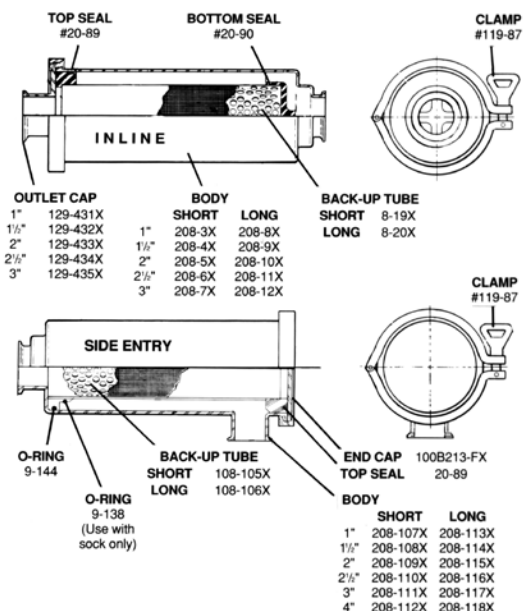



PART NUMBERS FOR SOCK AND MESH RATING:

| MESH | ORDER NUMBER | | MICRON RATING | SPACE BETWEEN WIRES | % OPEN | WIRE SIZE |
|------|--------------|--------|---------------|---------------------|--------|-----------|
| | SHORT | LONG | | | | |
| 6 | 8-137X | 8-138X | 3353 | 0.132 | 62.7 | 0.035 |
| 8 | 8-130X | 8-131X | 2540 | 0.100 | 64.0 | 0.025 |
| 10 | 8-126X | 8-127X | 1905 | 0.075 | 56.3 | 0.025 |
| 12 | 8-132X | 8-133X | 1524 | 0.060 | 51.8 | 0.023 |
| 16 | 8-83X | 8-84X | 1130 | 0.045 | 50.7 | 0.017 |
| 20 | 8-29X | 8-30X | 864 | 0.034 | 46.2 | 0.016 |
| 30 | 8-85X | 8-86X | 533 | 0.021 | 40.8 | 0.012 |
| 40 | 8-13X | 8-16X | 381 | 0.015 | 36.0 | 0.010 |
| 50 | 8-128X | 8-129X | 280 | 0.011 | 30.3 | 0.009 |
| 60 | 8-31X | 8-32X | 229 | 0.009 | 30.5 | 0.008 |
| 80 | 8-14X | 8-17X | 178 | 0.007 | 31.4 | 0.006 |
| 100 | 8-33X | 8-34X | 140 | 0.006 | 36.0 | 0.004 |
| 150 | 8-15X | 8-18X | 104 | 0.004 | 37.4 | 0.003 |
| 200 | 8-103X | 8-104X | 73 | 0.003 | 33.6 | 0.002 |
| 325 | 8-119X | 8-120X | 43 | 0.002 | 30.0 | 0.014 |

| | ORDER NUMBER | | |
|---------------|--------------|------|---------------|
| Socks | Short | Long | Micron Rating |
| Cotton | 8-23 | 8-26 | 300 |
| Nylon | 8-24 | 8-27 | 800 |
| Rayon | 8-25 | 8-28 | 25-30 |

FILTER/STRAINER PRESSURE DROP CURVE FOR LONG AND SHORT UNITS

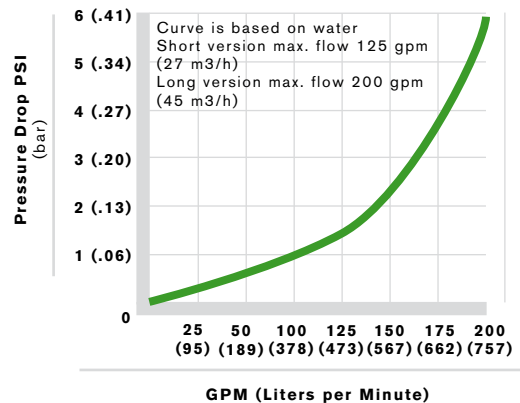

Pressure Rating: 200 PSI (14 BAR) at 70°F (21°C)
Filter Area: Short- 1 ft² (.09 m²) or Long- 2 ft² (.18 m²)

Based in Charlotte, North Carolina, SPX FLOW, Inc. (NYSE: FLOW) is a multi-industry manufacturing leader. For more information, please visit www.spxflow.com

SPX FLOW

611 Sugar Creek Road
 Delavan, WI 53115
 P: (262) 728-1900 or (800) 252-5200
 E: wcb@spxflow.com

Provided by:



SPX FLOW, Inc. reserves the right to incorporate our latest design and material changes without notice or obligation.

Design features, materials of construction and dimensional data, as described in this bulletin, are provided for your information only and should not be relied upon unless confirmed in writing. Please contact your local sales representative for product availability in your region. For more information visit www.spxflow.com.

The green "y" and "x" are trademarks of SPX FLOW, Inc.

ISSUED 10/2019 FH-1843

COPYRIGHT © 2019 SPX FLOW, Inc.