

Instruction Manual

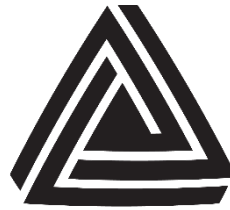

Anderson Instrument Co. Inc.
156 Auriesville Road
Fultonville, NY 12072
1-800-833-0081
www.anderson-negele.com

ANDERSON-NEGELE

Instrument Model Number _____

Instrument Serial Number _____



BC110 Controller

Proprietary Notice

The information contained in this publication is derived in part from proprietary and patent data. This information has been prepared for the expressed purpose of assisting operating and maintenance personnel in the efficient use of the instrument described herein. Publication of this information does not convey any rights to use or reproduce it or to use for any purpose other than in connection with the installation, operation and maintenance of the equipment described herein.

Printed in USA. All Rights Reserved.



WARNING!

This instrument contains electronic components that are susceptible to damage by static electricity. Proper handling* procedures must be observed during the removal, installation, or handling of internal circuit boards or devices.

*Handling Procedure

1. Power to unit must be removed.
2. Personnel must be grounded, via wrist strap or other safe, suitable means, before any printed circuit board or other internal device is installed, removed or adjusted.
3. Printed circuit boards must be transported in a conductive bag or other conductive container. Boards must not be removed from protective enclosure until the immediate time of installation. Removed boards must be placed immediately in protective container for transport, storage, or return to factory.

Comments

This instrument is not unique in its content of ESD (electrostatic discharge) sensitive components. Most modern electronic designs contain components that utilize metal oxide technology (NMOS, CMOS, etc.). Experience has proven that even small amounts of static electricity can damage or destroy these devices. Damaged components, even though they appear to function properly, may exhibit early failure.



SAFETY INSTRUCTIONS

The following instructions must be observed.

- This instrument was designed and is checked in accordance with regulations in force EN 60950 ("Safety of information technology equipment, including electrical business equipment"). A hazardous situation may occur if this instrument is not used for its intended purpose or is used incorrectly. Please note operating instructions provided in this manual.
- The instrument must be installed, operated and maintained by personnel who have been properly trained. Personnel must read and understand this manual prior to installation and operation of the instrument.
- This instrument is internally fused. Replace the internal fuse with the following specified type and rating only:

<u>Input Power</u>	<u>Recommended Fuse</u>
115 VAC	160 mA slow blow fuse

Disconnect power supply before replacing fuse!

- The manufacturer assumes no liability for damage caused by incorrect use of the instrument or for modifications or changes made to the instrument.

Symbols Used on Unit

Number	Symbol	Publication	Description
1	===	IEC 417, No. 5031	Direct current
2		IEC 417, No. 5172	Equipment protected throughout by DOUBLE INSULATION or REINFORCED INSULATION (equivalent to Class II of IEC 536—see annex H)
3		ISO 3864, No. B.3.1	Caution (refer to accompanying documents)

Technical Improvements

The manufacturer reserves the right to modify technical data without prior notice.

Table of Contents

1 Description	5
1.1 Unit Description:	5
1.2 Unit Features:	5
1.3 Specifications:	5
1.4 Dimensions:	9
2 Installation	10
2.1 General Mounting Hints:	10
2.2 Mounting Diagrams:	10
3 Applications	11
3.1 Liquid Volume	11
3.2 Batching	12
4 WIRING	13
4.1 Typical Batcher Wiring:	13
4.2 Typical Rate/Total Wiring:	13
5 UNIT OPERATION	14
5.1 Front Panel Operation Concept for Run Mode	14
5.2 General Operation	14
5.3 Ratemeter/Totalizer Operation	15
5.3.1 Password Protection for Rate/Total mode	15
5.3.2 Relay Operation in Rate/Total mode	15
5.3.3 Pulse Output in Rate/Total mode	15
5.3.4 Analog Output in Rate/Total mode	15
5.3.5 RS-232 Serial Port Operation in Rate/Total mode	16
5.4 Batcher Operation	16
5.4.1 Batcher Configuration	16
5.4.2 Password Protection for Batcher Mode	17
5.4.3 Relay Operation in Batcher mode	18
5.4.4 Pulse Output in Batcher mode	18
5.4.5 Analog Output in Batcher mode	18
5.4.6 RS-232 Serial Port Operation in Batcher mode	18
6 PROGRAMMING	19
6.1 Front Panel Operation Concept for Program Mode	19
6.2 EZ Setup	20
6.3 Setup Menus	21
6.4 Setup Sub-Menu	22
6.4.1 SELECT EZ SETUP	22
6.4.2 INSTRUMENT TYPE	22
6.4.3 SETUP INDICATORS (Total)	23
6.4.4 SETUP INDICATORS (Rate)	23
6.4.5 SETUP FLOW INPUT (Pulse – chA & chA=chB)	24
6.4.6 SETUP FLOW INPUT (Pulse – Quadrature, Qx1 or Qx2)	25
6.4.7 SETUP PULSE OUTPUT	26
6.4.8 SETUP ANALOG OUTPUT	26
6.4.9 SETUP RELAYS	27
6.4.10 SETUP CONTROL INPUTS (Rate/Total)	28
6.4.11 SETUP CONTROL INPUTS (Batch)	28
6.4.12 SETUP REALTIME CLOCK (Time)	29
6.4.13 SETUP REALTIME CLOCK (Date)	29
6.4.14 SERIAL USAGE	30
6.4.15 SETUP DATALOG/PRINT (Configure)	31
6.4.16 SETUP DATALOG/PRINT (Select_list)	32
6.4.17 ADMINISTRATIVE SETUP	32
6.4.18 SETUP NETWORK CARD	33
7 Principals of Operation	34
7.1 General:	34
7.2 Flow Equations:	34
7.3 Linearization Table	34
7.3.1 Linearization Table General Information	34
7.3.2 Linearization Table for Pulse Inputs	34
7.3.3 Linearization Table Interpolation	34

8 Test, Service and Maintenance	35
8.1 Test Menus.....	35
8.2 Test Sub-Menus.....	36
8.2.1 Audit Trail.....	36
8.2.2 Error History.....	36
8.2.3 Print System Setup.....	36
8.2.4 Keypad test.....	37
8.2.5 Display test.....	37
8.2.6 Calibrate 0 mA Out.....	37
8.2.7 Calibrate 20mA Out.....	37
8.2.8 Pulse input test.....	38
8.2.9 Analog out test.....	38
8.2.10 Excitation out test.....	38
8.2.11 Pulse out test.....	38
8.2.12 Relay test.....	39
8.2.13 Control inputs test.....	39
8.2.14 Data logger utility.....	39
8.3 Internal Fuse Replacement.....	40
9 RS-232 Serial Port	41
9.1 RS-232 Port Description:.....	41
9.2 Instrument Setup by PC's over Serial Port.....	41
9.3 Operation of Serial Communication Port with Printers.....	41
9.4 BC110 RS-232 Port Pinout.....	41
10 Glossary of Terms	42
11 Diagnosis and Troubleshooting	45
11.1 Response of BC110 on Error or Alarm:.....	45
11.2 Diagnosis Flow Chart and Troubleshooting.....	46
11.3 Error & Warning Messages:.....	47
11.3.1 Sensor/Process Alarms.....	47
11.3.2 Self Test Alarms.....	47
12 Appendix a	48
12.1 Setup Menu Flowchart.....	48
13 Warranty and Return Statement	49
Warranty.....	49
Limitations.....	49
Returns.....	49

1 DESCRIPTION

1.1 UNIT DESCRIPTION:

The BC110 Flow Computer satisfies the rate, total and batching instrument requirements for a variety of pulse producing flowmeter types in liquid applications. Multiple flow equations and instrument functions are available in a single unit with many advanced features.

The alphanumeric display shows measured and calculated parameters in easy to understand format. Single key direct access to measurements and display scrolling is supported.

The versatility of the BC110 permits a wide measure of versatility within the instrument package. The various hardware inputs and outputs can be "soft" assigned to meet a variety of common application needs. The user "soft selects" the usage of each input/output while configuring the instrument. Consider the following illustrative examples.

The user can assign the standard RS-232 Serial Port for data logging, transaction printing, or for connection to a modem for remote meter reading.

1.2 UNIT FEATURES:

The BC110 Flow Computer offers the following features:

Compatible with Pulse Producing Flowmeters

Multiple Instrument Functions; Rate, Total, Batching

Menu Selectable Hardware & Software Features

Two Line OLED Display

Automatic Batch Overrun Compensation

Isolated Pulse Output Standard

Isolated Analog Output Standard

Versatile RS-232 Port Standard

Linearization Capability Standard

DIN Enclosure with Two Piece Connectors

EZ Setup Feature

Advanced Batching Features

1.3 SPECIFICATIONS:

Environmental

Indoor Use

Altitude up to 2000m

Operating Temperature: 0°C to +50°C
(-20°C to 55°C optional)

Storage Temperature: -40°C to +85 C

Maximum Relative Humidity: 80% for
temperatures up to 31°C decreasing linearly
to 50% RH at 40°C

Main supply voltage fluctuations not to exceed
±10% of the nominal voltage

Transient overvoltage according to
INSTALLATION CATEGORY II (see UL 3101-1
Annex J)

POLLUTION DEGREE 2 in accordance with IEC
664 (see 3.7.3)

Materials: UL, CSA, VDE approved

Approvals

CE Compliant Light Industrial, UL File #:
E192404, C/UL

Display

Type: 2 lines of 20 characters

Types: Backlit LCD, VFD or OLED

Character Size: 0.2" nominal

User selectable label descriptors and units of
measure

Keypad

Keypad Type: Membrane Keypad

Keypad Rating: Sealed to Nema 4

Number of keys: 16

PAGE 6

Enclosure

Size: See Dimensions (section 2.2)
Depth behind panel: 6.5" including mating connector
Type: DIN
Materials: Plastic, UL94V-0, Flame retardant
Bezel: Textured per matt finish
Equipment Labels: Model, safety, and user wiring

Power Input

The factory equipped power option is internally fused.
An internal line to line filter capacitor is provided for added transient suppression.
110VAC: 85 to 127 Vrms, 50/60 Hz

Flow Inputs / Pulse Inputs:

Number of Flow Inputs: one
Configurations supported: single input with or without quadrature (menu selectable)
Input Impedance: 10 K Ω nominal
Pullup Resistance: 10 K Ω to 5 VDC (menu selectable)
Pull Down Resistance: 10 K Ω to common Trigger Level: (menu selectable)
High Level Input
Logic On: 3 to 30 VDC
Logic Off: 0 to 1 VDC Low Level Input (mag pickup)
Selectable sensitivity: 10 mV & 100 mV
Minimum Count Speed: User selectable down to 1 pulse in 99 sec.
Maximum Count Speed: Selectable: 0 to 20kHz
Overvoltage Protection: 50 VDC
Fast Transient: Protected to 500 VDC (Capacitive Clamp)

Control Inputs

Switch Inputs are menu selectable for Start, Stop, Reset, Lock, Inhibit, Alarm Acknowledge, Print or Not Used.
Control Input Specifications
Input Scan Rate: 10 scans per second Logic 1: 4 - 30 VDC
Logic 0: 0 - 0.8 VDC
Transient Suppression: 500 V fast transient (Capacitive Clamp)
Input Impedance: 100 K Ω
Control Activation: Positive Edge or Pos. Level based on product definition

Excitation Voltage

110/220 VAC Powered Units
Menu Selectable: 5, 12 or 24 VDC @ 100mA
24 VDC Powered Units
Menu Selectable: 5 or 12 VDC @ 100mA
12 VDC Powered Units
5 VDC @ 100mA

Relay Outputs

The relay outputs are menu assignable to (Individually for each relay) Low Rate Alarm, Hi Rate Alarm, Prewarn Alarm, Preset Alarm, General purpose warning (security), overrun or not used.
Number of relays: 2 (4 optional)
Contact Style: Form C contacts
Contact Ratings: 250 VAC @ 5 amps
30 VDC @ 5 amps
Fast Transient Threshold: 1000 V

Serial Communication

The serial port can be used for printing, datalogging, modem connection and communication with a computer.
RS-232:
Device ID: 01-99
Baud Rates: 300, 600, 1200, 2400, 4800, 9600, 19200
Parity: None, Odd, Even
Handshaking: None, Software, Hardware
Print Setup: Configurable print list and formatting

Analog Output

The analog output is menu assignable to correspond to the Rate or Total.
Type: Isolated Current Sourcing Isolated I/P/C: 500 V
Available Ranges: 4-20 mA, 0-20 mA
Resolution: 12 bit
Accuracy: 0.05% FS at 20 Degrees C
Update Rate: 1 update/sec minimum
Temperature Drift: Less than 200 ppm/C
Maximum Load: 1000 ohms (at nominal line voltage)
Compliance Effect: Less than .05%
Span 60 Hz rejection: 40 dB minimum
Calibration: Operator assisted Learn Mode
Averaging: User entry of DSP Averaging constant to cause a smooth control action.

Isolated Pulse output

The isolated pulse is assigned to Volume Total.

Isolation I/O/P: 500 V

Pulse Output Form: Isolated Photomos Relay

Maximum On Current: 125 mA

Maximum Off Voltage: 30 VDC

Saturation Voltage: 1.0 VDC

Maximum Off Current: 0.1 mA

Pulse Duration:

User selectable: 10mSec, 100mSec

Pulse output buffer: 8 bit

Fault Protection

Reverse polarity: Shunt Diode

Transient Protection: 500 VDC

(Capacitive Clamp)

Operating Mode

The Flow Computer can be thought of as making a measurement of flow and then performing calculations which are then updated periodically on the display as rate and total. The pulse output, analog output and the alarm relays are also updated. The cycle then repeats itself.

Step 1: Update the measurements of input signals- Raw Input Measurements are made at each input.

Step 2: Compute the Volumetric Flow- Uncompensated flow is the term given to the flow in volume units. The value is computed based on the flowmeter input type selected and augmented by any performance enhancing linearization that has been specified by the user.

Step 3: Check Flow Alarms- The flow alarm functions have been assigned to flow rate during the setup of the instrument. A comparison is now made by comparing the current flow rates against the specified hi and low limits.

Step 4: Compute the Flow Totals by Summation- A flow total increment is computed for each flow rate. This increment is computed by dividing the pulses by the K-Factor and then summing. The totalizer format also includes provisions for total rollover.

Step 5: Total Preset Comparisons- The total associated with a preset function is then compared against the corresponding preset value and any required control actions taken.

Step 6: Pulse Output Service- The pulse output is next updated by scaling the total increment which has just been determined by the pulse output scaler and summing it to any residual pulse output amount.

Step 7: Compute the Analog Output- This designated flow rate value is now used to compute the analog output.

Step 8: Update Display and Printer Output- The instrument finally runs a task to update the various table entries associated with the front panel display and serial outputs.

Setup Mode

The setup mode is password protected by means of a numeric lock out code established by the user. In addition, a secret, manufacturers numeric unlock entry sequence is available.

The system also provides a minimum implementation of an "audit trail" which tracks significant setup changes to the unit. This feature is increasingly being found of benefit to users or simply required by Weights and Measurement Officials in systems used in commerce, trade, or "custody transfer" applications.

A Worksheet is provided to assist the user in setting up the instrument. An Easy Setup (EZ Setup) feature is offered in the setup menu. The EZ Setup routine is a quick and easy way to configure the unit for the most commonly used instrument functions.

The setup mode has numerous subgrouping of parameters needed for flow calculations. There is a well-conceived hierarchy to the setup parameter list. Selections made at the beginning of the setup affect offerings further down in the lists.

In the setup mode, the flow computer activates the correct setup variables based on the instrument configuration, the flow equation, and the hardware selections, the flow transmitter type, and meter

PAGE 8

enhancements (linearization) options selected. All required setup parameters are enabled. All setup parameters not required are suppressed.

A help line prompt is provided for each entry. In addition, a help message is available which may be accessed by depressing the "HELP" key.

Also note that in the setup mode are parameter selections which have preassigned industry standard values. The unit will assume these values unless they are modified by the user.

Maintenance (Test) Mode:

The Maintenance Mode of the BC110 provides a number of specialized utilities required for instrument checkout on start-up, setup documentation and data logger access.

A password is required to gain access to this specialized mode of operation. Quality and maintenance personnel will find this mode of operation very useful. It is also useful for factory testing.

Many of these tests may be used during start-up of a new system. Inputs signals may be read, and output signals may be exercised to verify the electrical interconnects before the entire system is put on line.

The following action items may be performed in the Maintenance Mode:

Print Setup Report

Examine Audit Trail

Examine Error History

Perform Keypad Checkout

Perform Display Checkout

Perform Pulse Input Checkout

Perform Pulse Output Checkout

Perform Control Input Checkout

Perform Relay Output Checkout

Perform Analog Output Checkout

Calibrate Analog Output using the Learn Feature

Perform Excitation Output Test

Examine or Dump Data Logger

RS-232 Serial Port

The BC110 has a general-purpose RS-232 Port which may be used for any one of the following purposes:

Transaction Printing

Data Logging

Remote Metering by Modem (optional)

Computer Communication Link

Configuration by Computer

Print System Setup

Print Malfunction History

Operation of Serial Communication Port with Printers

BC110's RS-232 channel supports a number of operating modes. One of these modes is intended to support operation with a printer in metering applications requiring transaction printing, data logging and/or printing of maintenance reports.

For transaction printing, the user defines the items to be included in the printed document. The user can also select what initiates the transaction print generated as part of the setup of the instrument. The transaction document may be initiated via a front panel key depression, a remote contact closure, upon completion of a batch, time of day or at a timed interval.

In data logging, the user defines the items to be included in each data log as a print list. The user can also select when or how often he wishes a data log to be made. This is done during the setup of the instrument as either a time of day or as a time interval between logging.

The system setup and maintenance report lists all the instrument setup parameters and usage for the current instrument configuration. In addition, the Audit trail information is presented along with a status report listing any observed malfunctions which have not been corrected.

PAGE 9

The user initiates the printing of this report at a designated point in the menu by pressing the requested key on the front panel.

Operation of Serial Port with Modems (optional) The BC110 RS-232 channel supports a number of operating modes. One of these modes is intended to support operation with a modem in remote metering applications.

An external modem is intentionally being used with the BC110. This permit use with the variety of modem standards worldwide while avoiding the specialized approvals required for equipment that is deemed to fall under the category of telecommunication equipment.

In the modem mode, the BC110 is assumed to be operating in a remote metering role. In addition, the BC110 will be capable of initiating a call to a designed telephone number in the event of a metering malfunction.

1.4 DIMENSIONS:

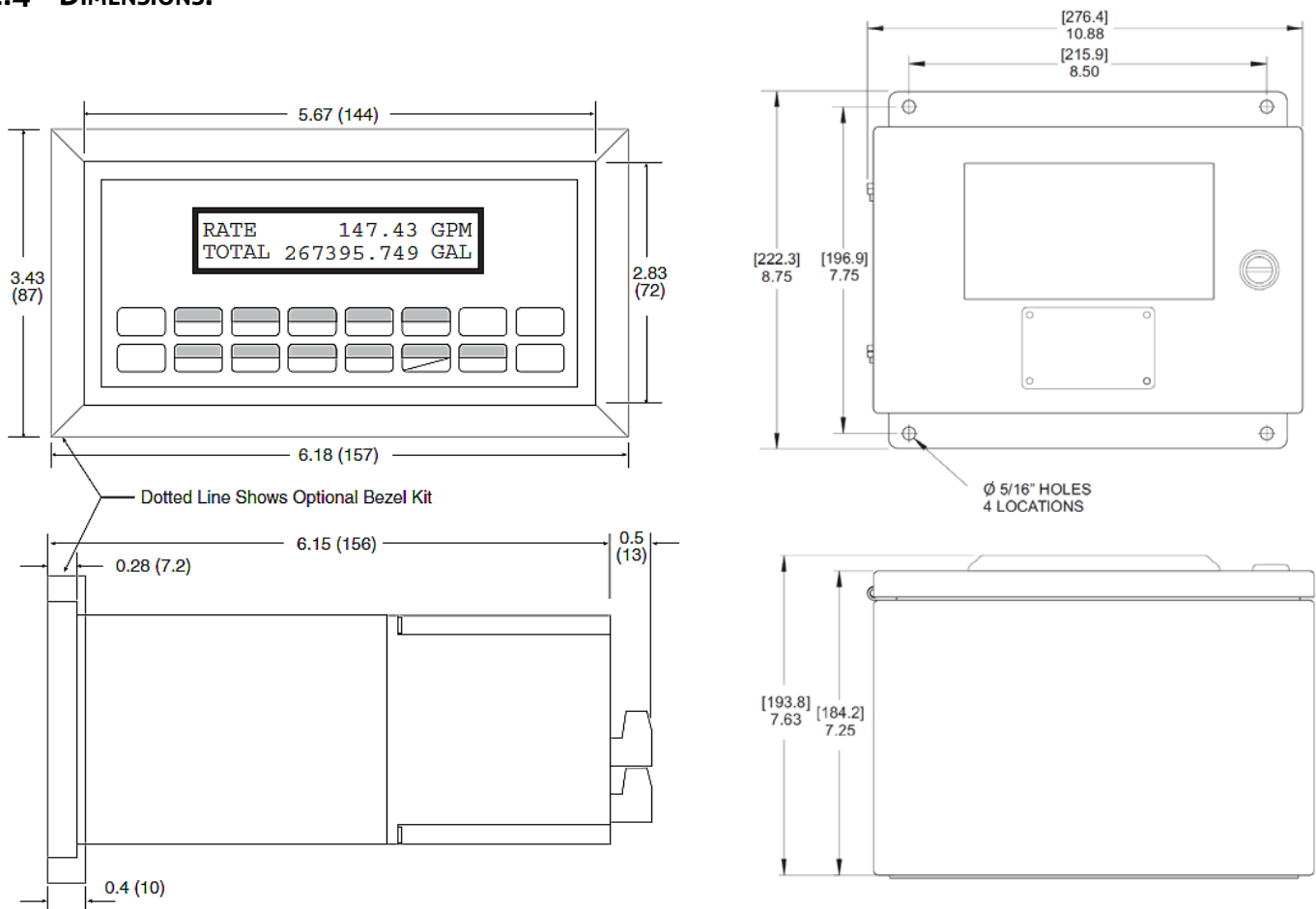

2 INSTALLATION

2.1 GENERAL MOUNTING HINTS:

The BC110 Flow Computer should be located in an area with a clean, dry atmosphere which is relatively free of shock and vibration. The unit is installed in a 5.43" (138mm) wide by 2.68" (68mm) high panel cutout. (see Mounting Dimensions) To mount the Flow Computer, proceed as follows:

- a. Prepare the panel opening.
- b. Slide the unit through the panel cutout until it touches the panel.
- c. Install the screws (provided) in the mounting bracket and slip the bracket over the rear of the case until it snaps in place.
- d. Tighten the screws firmly to attach the bezel to the panel. 3 in. lb. of torque must be applied and the bezel must be parallel to the panel.

Termination Connectors:

Minimum Wire Gauge: 22 AWG
 Maximum Wire Gauge: 14 AWG
 Voltage/current limits are limited by unit specifications.

Permanently Connected Equipment:

UL 3101-1, Section 6.12.2.1 specifies that:

- A switch or circuit breaker shall be included in the building installation;
- It shall be in close proximity to the equipment and within easy reach of the OPERATOR;
- It shall be marked as the disconnecting device for the equipment.

NOTE: Ensure that the switch or circuit breaker chosen is suitable for the power requirements of the unit.

2.2 MOUNTING DIAGRAMS:



IMPORTANT!

To provide protection type IP65/NEMA 4X, the unit must be mounted with the bezel adaptor and the gasket (supplied with the mounting kit). The bezel must be glued to the unit with silicon. (see Instructions supplied with the mounting kit)

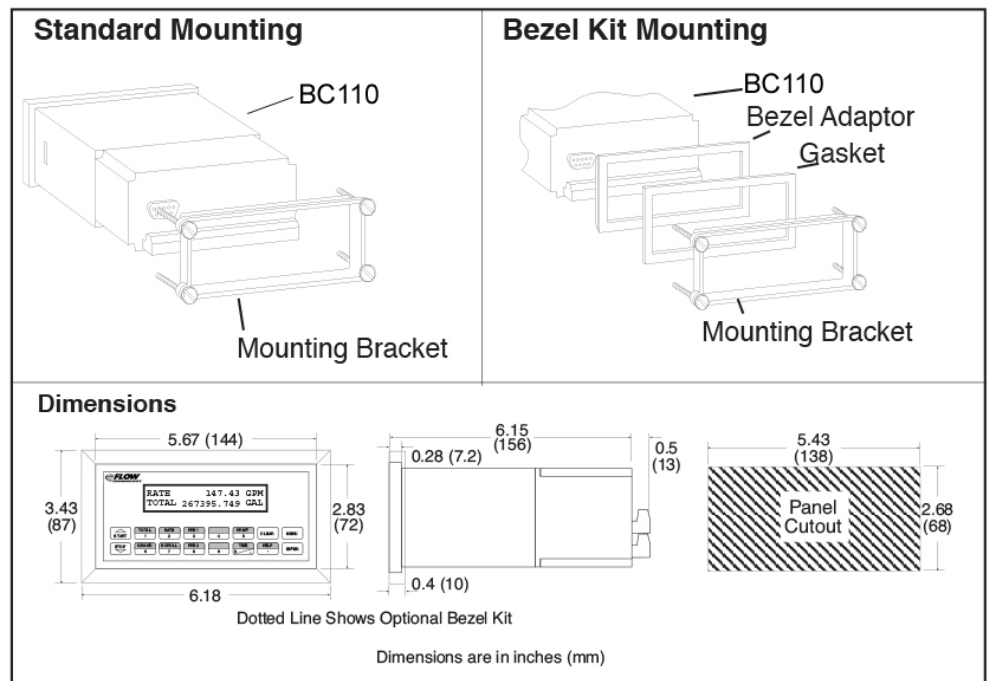

3 APPLICATIONS

3.1 LIQUID VOLUME

Measurements:

A flowmeter measures the actual volume in a liquid line.

Calculations:

For Flowmeters with Pulse Outputs, Volume flow is calculated using the flowmeter frequency output and the user entered K-Factor or Linearization Table.

Output Results:

- Display Results
Flow Rate, Resettable Total, Non-Resettable Total
- Pulse Output
Total
- Analog Output
Rate or Total
- Relay Outputs
Rate or Total Alarms

Applications:

The Flow Computer can monitor actual volume flow and total of any liquid. Flow alarms are provided via relays and datalogging is available via serial outputs.

Liquid Volume Illustration

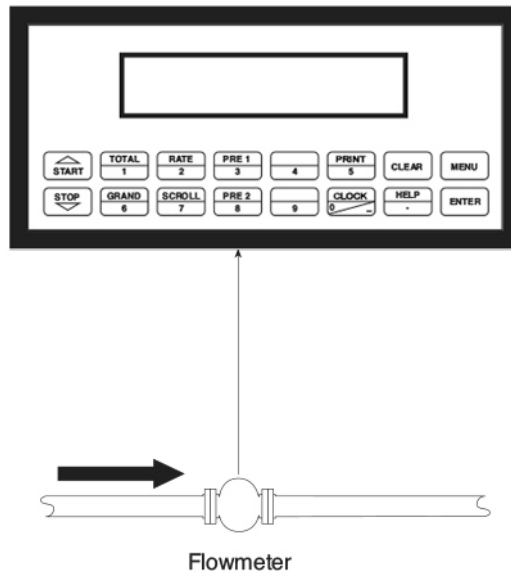

Calculations

Pulse Input; Average K-Factor or Linearization Table

$$\text{Volume Flow} = (\text{input frequency} * \text{time scale factor}) / \text{K-Factor}$$

3.2 BATCHING

Measurements:

A flowmeter measures the actual volume in a liquid line.

Calculations:

For Flowmeters with Pulse Outputs, Volume flow is calculated using the flowmeter frequency output and the user entered K-Factor or Linearization Table.

Output Results:

- Display Results
- Flow Rate, Batch Total, Non-Resettable Total
- Pulse Output
- Total
- Analog Output
- Rate or Total
- Relay Outputs
- Batch Total, Rate, or Alarms

Applications:

Batching and monitoring flow and total of any liquid. Batching is accomplished via relays and datalogging is available via serial outputs.

Batching Illustration

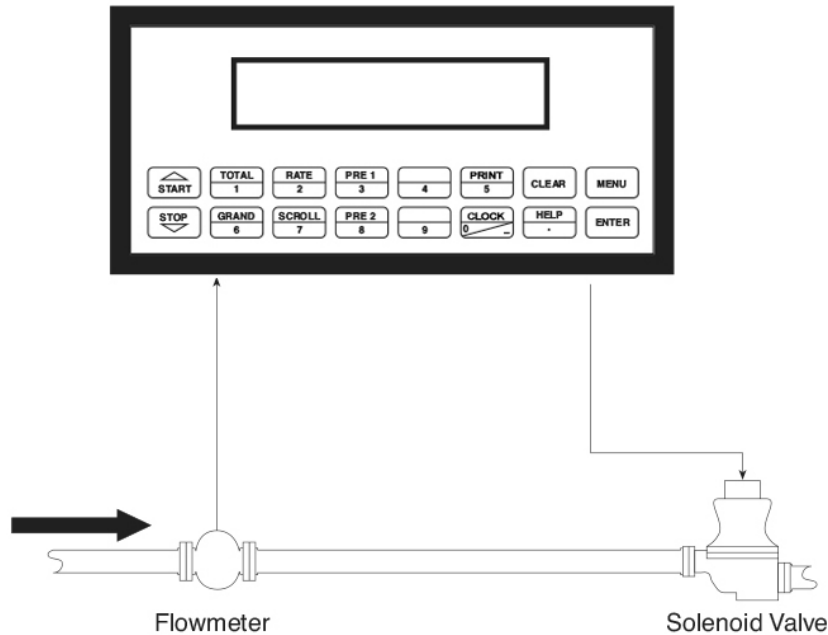

Calculations

Pulse Input; Average K-Factor or Linearization Table
Volume Flow = (input frequency * time scale factor) / K-Factor

4 WIRING

4.1 TYPICAL BATCHER WIRING:

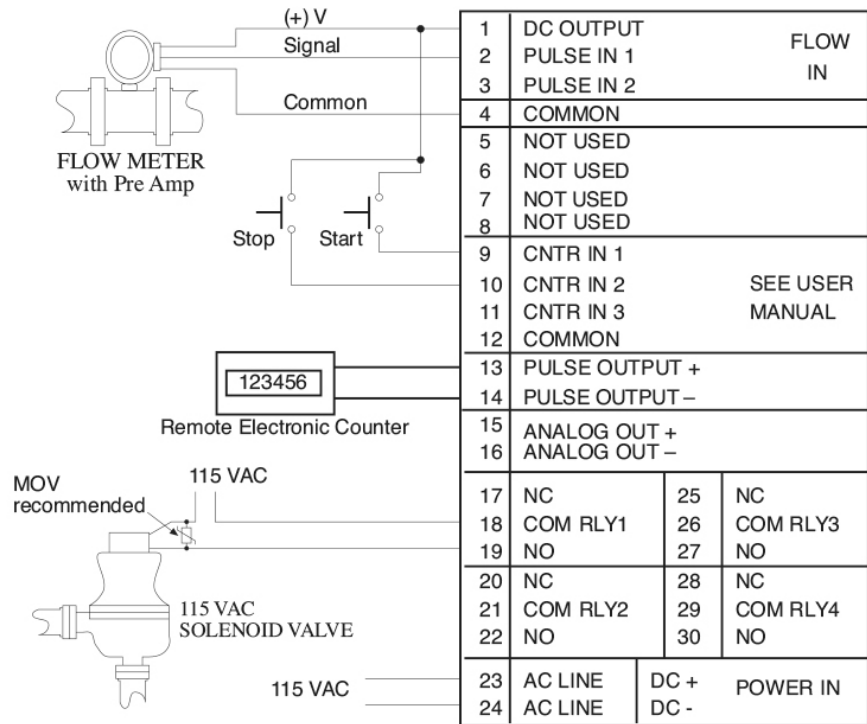

4.2 TYPICAL RATE/TOTAL WIRING:

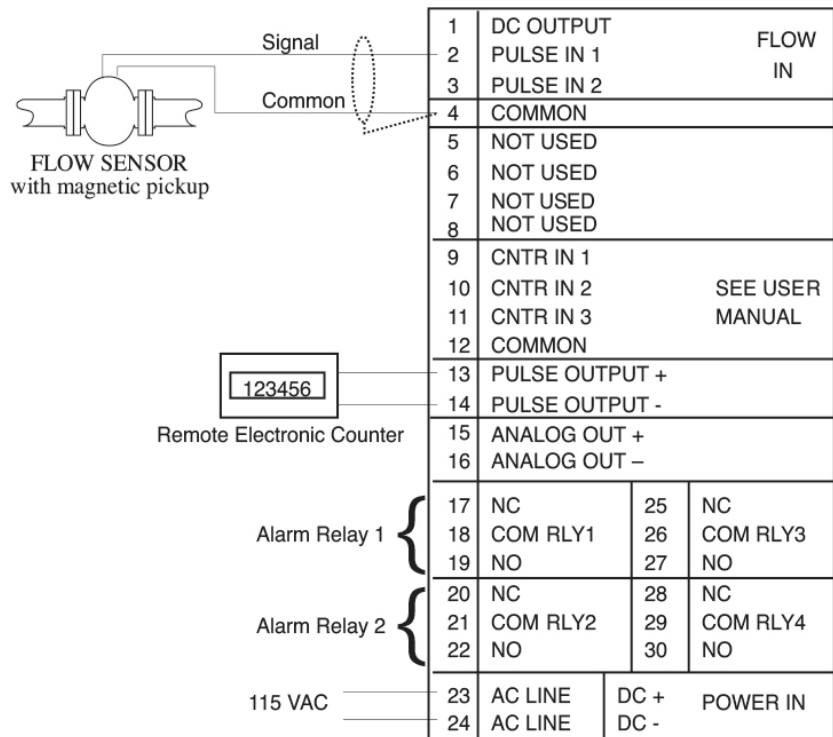

5 UNIT OPERATION

5.1 FRONT PANEL OPERATION CONCEPT FOR RUN MODE

The BC110 is fully programmable through the front panel. Please review the following usage summary before attempting to use the instrument.

HELP

On-line help is provided to assist the operator in using this product. The help is available during RUN and SETUP modes simply by pressing the HELP key. The HELP key is used to enter decimals when entering numeric values.

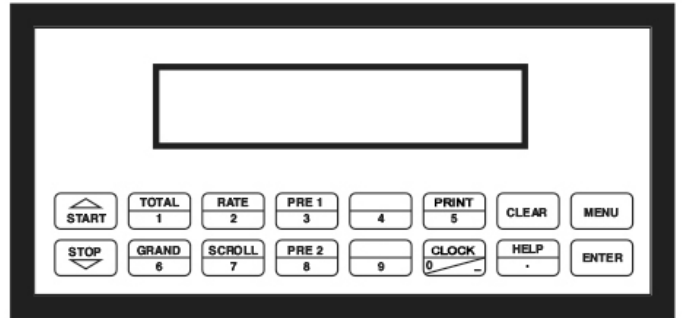

FUNCTION KEYS

In the RUN mode, several keys have a special, direct access feature, to display an item of interest (i.e. RATE, TOTAL, PRE 1, etc.). Press the key to view your choice. Press the SCROLL key to return to scrolling display.

CLEARING TOTALIZER

To clear the total, you must press the TOTAL Function Key 3 times quickly to select the total. Once the total is selected, press the CLEAR key to reset the total. The operator will be prompted to enter password if the unit is locked.

NOTE: In the Batcher Mode, simply press the CLEAR key to reset the total (the batcher must be stopped or finished batching). It is not necessary to press the TOTAL Function Key first.

CLEARING GRAND TOTAL

To clear the grand total, you must press the GRAND Function Key 3 times quickly to select the grand total. Once the grand total is selected, press the CLEAR key to reset the grand total. The operator will be prompted to enter password if the unit is locked.

PRESET KEYS

In the RUN mode, PRE 1, PRE 2, keys are used to view and/or change the preset setpoints. To view the Presets, simply press the desired Preset key once. Rapidly press the Preset keys 3 times, then press the Clear key for direct editing of the preset setpoints.

SCROLL

Rapidly press the Scroll key 3 times to setup a display list. Press the CLEAR key to remove old scroll list.

Press the function key for the item you wish to add Use the keys to assign the line.

Press the ENTER key to save scroll list.

PRINT

The PRINT key is used to print on demand. When the PRINT key is pressed, a user defined list of data (TOTAL, RATE, PRE 1, etc.) is sent to the RS232 port. A timed message of "PRINTING" will be displayed to acknowledge the print request.

SPECIAL BATCHING KEYS

The START and STOP keys are used only when batching to start and stop batches. The CLEAR key will clear the total without first pressing the TOTAL key (unit must be stopped). All other keys work the same in both Rate/Total mode and Batch mode. The Start and Stop keys operation are set by the control input settings. The Start options are: START or RESET/START. The Stop options are: STOP or STOP/RESET.

MENU KEY

The MENU key is used to enter the Setup and Test modes. Press the MENU key to enter the Setup and Test modes. The user will be prompted to enter a password if the unit is locked. (See section 6 for Setup mode, section 8 for Test mode). The MENU key is also used as "escape" in Setup and Test Programming. Pressing the MENU key while programming in the Sub-Menu groups will backup the display to that Sub-Menu group heading. Pressing the MENU key while viewing the Sub-Menu groups will backup the display to the Top Level Menu.

ACKNOWLEDGING ALARMS

Most alarm messages are self-clearing. Press the ENTER key to acknowledge and clear alarms.

NOTE: Some keys and functions are password protected. Enter the password to gain access.

The passwords are factory set as follows: Operator = 0; Supervisor = 2000

TIME/DATE

The TIME key is reserved for displaying Time and Date. To View the Time or Date, press the TIME key once.

5.2 GENERAL OPERATION

The unit can display: Rate, Total, Grand Total, Presets and Time of Day. The unit can be programmed to perform Ratemeter/Totalizer or Batching functions.

5.3 RATEMETER/TOTALIZER OPERATION

The Ratemeter/Totalizer mode is used primarily to monitor flowrate and accumulated total. The relays can be used to trigger on flow rate, total, or alarms.

5.3.1 Password Protection for Rate/Total mode

After an Operator and/or Supervisor Password is entered in the setup mode (see section 6.3, SETUP PASSWORD submenu), the unit will be locked. The unit will prompt the user for the password when trying to perform the following functions:

- Clear Total
- Clear Grand Total Enter Menu
- Edit Preset 1 (PRE 1 Key)
- Edit Preset 2 (PRE 2 Key)
- Edit Preset 3 (4 Key)
- Edit Preset 4 (9 Key)

The Supervisor password should be reserved for supervisors. The Supervisor password will allow access to restricted areas of the Setup and Test menus.

5.3.2 Relay Operation in Rate/Total mode

Up to four relays are available (two standard) for alarm outputs. The relays can be assigned to trip according to rate, total or general system alarms. The relays can be programmed for low or high alarms.

Preset 1 (RLY1) and Preset 2 (RLY2) are easily accessible by pressing the PRE 1 or PRE 2 key on the front panel. Preset 3 and Preset 4 are accessible by pressing the 4 or 9 keys.

5.3.3 Pulse Output in Rate/Total mode

The isolated pulse output (open collector) is assigned to Volume Total. The pulse output duration can be set for 10mS (50 Hz max) or 100mS (5 Hz max). A pulse output scale factor (pulse value) can be set to scale the pulse output. The pulse output is ideal for connecting to remote totalizers or other devices such as a PLC. See section 1.3 for electrical specifications.

5.3.4 Analog Output in Rate/Total mode

The analog output is menu assignable to correspond to the Volume Rate or Volume Total. The analog output is ideal for "trend" tracking using strip chart recorders or other devices.

5.3.5 RS-232 Serial Port Operation in Rate/Total mode

The RS-232 serial port can be used for programming (using the Setup Disk) or for communicating to printers and computers in the Operating Mode (Run Mode).

PC Communications:

The Setup Disk also allows the user to query the unit for operating status such as Flow Rate, Flow Total, Presets, etc.

Operation of RS-232 Serial Port with Printers:

Transaction Printing

For transaction printing, the user defines the items to be included in the printed document (see section 6.4.16 SET DATA OUTPUT, Select_list). The transaction document can be initiated by pressing the PRINT key or by a remote contact closure.

Data Logging

In data logging, the user defines the items to be included in each data log (see section 6.4.16 SET PRINTER OUTPUT, Select_list). The user can also select when (time of day) or how often (print interval) the data log is to be made (see section 6.4.15 SET PRINTER OUTPUT, Configure).

System Setup and Maintenance Report

The system setup and maintenance report lists all of the instrument setup parameters and usage for the current instrument configuration. The audit trail information and a status report is also printed. This report is initiated in the Test menu (see section 8.2.3 PRINT SYSTEM SETUP).

5.4 BATCHER OPERATION

The Batcher mode is used primarily to control batches. The main difference between the Batch mode and Rate/Total mode is the relay operation. The Batch mode allows the operator to "START" the unit via the front panel or remote input. Once started, the relays (RLY1 & RLY2) will energize and send a contact to a flow control device (i.e. solenoid valve or pump). The flow sensor will send a signal to the unit and total accumulation will begin. Just before the end of batch, when the Prewarn value (PRE 2) is reached, Relay 2 will drop out (this is ideal for flow slow down). When the final Batch amount (PRE 1) is reached, Relay 1 will drop out and the Batch is complete.

Several messages will be displayed during normal batch operation (i.e. Batch Fill, Batch Stopped). The keypad is disabled for the duration of these timed messages (approx. 2 sec).

5.4.1 Batcher Configuration.

When the unit is programmed for batch mode, several batch operation choices are available. These choices include: EZ Preset, Up or Down Counting, Maximum Batch Preset, Batch Overrun Compensation, Auto Batch Restart, Time Delay, Flow Signal Timeout, Maximum Drain Time, Slow Start Quantity, Start or Reset/Start, and Stop or Stop/Reset.

EZ Preset

A selectable mode of batching where user can press "PRE 1", then "ENTER" then the quantity to be batched, then "START" for a quick enter-start sequence.

Batch Count Mode

The Batch Count Mode allows the user to choose whether the unit will batch up to a preset value or batch down from a preset value to zero.

Maximum Batch Preset

The Maximum Batch Preset allows the user to program the Maximum Batch value allowed to be entered by the operator. If an operator should try to program a batch higher than this value, the unit will not allow the value to be entered and will prompt the user with an error message saying that the permitted Maximum Batch Preset size has been exceeded.

Batch Overrun

The Batch Overrun is used for batch applications that have slow responding valves and a consistent batching

flowrate. When the Batch Overrun is set, the unit will compensate for batch overruns by computing an averaged overrun value from the last four batches. This average is used to internally adjust the batch setpoint to minimize overrun. The maximum drain time must be set greater than the slowest valve response time for proper operation of this feature.

Auto Batch Restart

The Auto Batch Restart function allows the user to set an amount of time to automatically restart a batch after the completion of a batch. This time can be set from 1 to 99 seconds.

Flow Signal Timeout

The Flow Signal Timeout allows the user to enter a timeout of 0 to 99 seconds. If a batch is "Filling" and zero flow persists for more than the user entered time then the batch will be aborted. This prevents over flows due to faulty flow sensors and/or wiring.

Maximum Drain Time

The unit declares that a batch is "done" when the flow rate equals "0". A flow rate may be present long after the Preset Relay de-energizes due to slow reacting valves or leaky valves. The Maximum Drain Time allows the user to enter an amount of time (0 to 99 seconds) to wait before declaring "Batch Done". After the Preset Batch quantity is reached, the unit will declare "Batch Done" when the flow rate is "0" or the Maximum Drain Time has expired. The batch data will then be available for printing and datalogging.

Slow Start Quantity

The Slow Start Quantity is a function that allows an amount to be entered for a Slow Start of fill. This function requires two stage valve control. RLY 1 (slow flow) will energize for Slow Start and RLY 2 (fast flow) will energize after the Slow Start Quantity has been delivered. This helps reduce turbulence when filling an empty container.

Start, Reset/Start and Stop, Stop/Reset

When configuring the control inputs, Control Input1 can be set for START or RESET/START. When set for START, the unit will start batching when a signal is applied to Control Input 1 or the front panel Start key is pressed. A separate Reset signal or CLEAR key depression must be used to clear the previous batch total. When set for RESET/START, the unit will automatically reset then start when a signal is applied to Control Input1 or the front panel Start key is pressed (provided that the pervious batch was completed). If a previous batch was stopped during a batch cycle, the unit will Start from where it was stopped.

Control Input 2 can be set for STOP or STOP/RESET. When set for STOP, the unit will stop batching when a signal is applied to Control Input 2 or the front panel Stop key is pressed. A separate Reset signal or CLEAR key depression must be used to clear the batch total. When set for STOP/RESET, a running batch will stop when a signal is applied to Control Input 2 or the front panel Stop key is pressed. If the unit is Stopped or after a completed batch, the unit will reset when a signal is applied to Control Input 2 or the front panel Stop key is pressed.

NOTE: Applying a voltage level to Control Input 2 will inhibit and override all Start inputs in either mode.

5.4.2 Password Protection for Batcher Mode

After an Operator and/or Supervisor Password is entered in the setup mode (see section 6.3, SETUP PASSWORD Sub-menu), the unit will be locked. The unit will prompt the user for the password when trying to perform the following functions:

- Clear Grand Total
- Enter Menu

The Supervisor password should be reserved for supervisors. The Supervisor password will allow access to restricted areas of the Setup and Test menus.

The passwords are factory set as follows:

- Operator = 0
- Supervisor = 2000

NOTE: A password of "0" should not be used since it will leave the unit unlocked and open to accidental changes.

5.4.3 Relay Operation in Batcher mode

Up to four relays are available (two standard) for alarm outputs. Preset 1 (RLY1) is reserved for batch amount, Preset 2 (RLY2) is reserved for prewarn. (see section 5.4 Batcher Operation for Relay 1 & Relay 2 functions) Preset 1 (RLY1) and Preset 2 (RLY2) are easily accessible by pressing the PRE 1 or PRE 2 key on the front panel. Preset 3 and Preset 4 are accessible by pressing the 4 or 9 keys. Relays 3 and 4 can be assigned to trip according to rate, total, overrun or alarm. When Rate is selected, the relays can be programmed for low or high alarms. When N.A (not assigned) is selected, the relays may be tripped via serial commands. Alternately, Preset 2, 3 or 4 may be used to enter alternate information and can be printed in the print list for transaction history.

5.4.4 Pulse Output in Batcher mode

The isolated pulse output (open collector) is assigned to Volume Total. The pulse output duration can be set for 10mS (50 Hz max) or 100mS (5 Hz max). A pulse output scale factor (pulse value) can be set to scale the pulse output. The pulse output is ideal for connecting to remote totalizers or other devices such as a PLC. See section 1.3 for electrical specifications.

5.4.5 Analog Output in Batcher mode

The analog output is menu assignable to correspond to the Volume Rate or Volume Total. The analog output is ideal for "trend" tracking using strip chart recorders or other devices.

5.4.6 RS-232 Serial Port Operation in Batcher mode

The RS-232 serial port can be used for programming (using the Setup Disk) or for communicating to printers and computers in the Operating Mode (Run Mode).

PC Communications:

The Setup Disk also allows the user to query the unit for operating status such as Flow Rate, Flow Total, Presets, etc.

Operation of RS-232 Serial Port with Printers:

Transaction Printing

For transaction printing, the user defines the items to be included in the printed document (see section 6.4.16 SET DATA OUTPUT, Select_list). The transaction document can be initiated by pressing the PRINT key, by a remote contact closure or print at end of batch.

Data Logging

In data logging, the user defines the items to be included in each data log (see section 6.4.16 SET PRINTER OUTPUT, Select_list). The user can also select when (time of day) or how often (print interval) the data log is to be made (see section 6.4.15 SET PRINTER OUTPUT, Configure).

System Setup and Maintenance Report

The system setup and maintenance report lists all of the instrument setup parameters and usage for the current instrument configuration. The audit trail information and a status report is also printed. This report is initiated in the Test menu (see section 8.2.3 PRINT SYSTEM SETUP).

6 PROGRAMMING

6.1 FRONT PANEL OPERATION CONCEPT FOR PROGRAM MODE

The BC110 is fully programmable through the front panel. Please review the following usage summary before attempting to use the instrument.

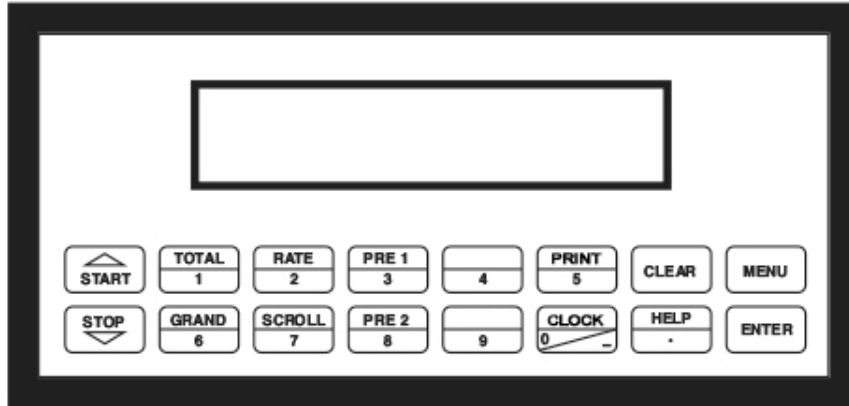

6.1.1 Setup Mode:

MODE CHANGES

Pressing the MENU key will offer selections of RUN, SETUP, TEST. RUN is the normal operating mode for the instrument. SETUP offers various sub-menus used for instrument setup. TEST offers various sub-menus for Test, Calibration and System Start-up testing.

Sub-menu GROUP NAVIGATION

Use the UP and DOWN arrow keys to navigate up and down through the Sub-Menu groups when in the SETUP or TEST mode. Press the ENTER key to enter a desired setup or test Sub-Menu group.

SELECTION OF ITEM

During setup, the unit will often offer multiple choices for a given topic. The topic prompt appears on the top line of the display. The choices are shown on the lower line of the display.

To select an item, press the key (in top row) beneath the desired choice. The selected choice will blink. Press the ENTER key to accept the selected choice.

NUMERIC ENTRY

The keys labeled "0 - 9", "-", ".", CLEAR and ENTER are used to enter numerical values. A leading 0 will assume that you intend to enter a minus "-" sign. Press the CLEAR key to clear the existing value and to enable editing. Enter the digits of your desired values, press ENTER to accept the value.

TEXT CHARACTER ENTRY

Some setup items (i.e. Descriptors, Units Label) require the user to enter text characters. Press CLEAR to enable editing. The UP and DOWN arrow keys are used to scroll through the available character sets for each individual character. Press the ENTER key to accept the character and advance to the next character.

6.2 EZ SETUP

The EZ Setup routine is a quick and easy way to configure the unit for the most commonly used instrument functions. This setup assumes that you are measuring Volumetric Flow using a high level, DC Pulsing flow sensor. Entering the EZ Setup mode automatically sets many features. This may cause any previously programmed information to be lost or reset. For a complete customized configuration, see sections 6.3 and 6.4.

<p>TOP LEVEL SETUP MENU</p> <p>EZ Setup Sub-menu Groups</p>	<pre> SELECT OPERATE STATE Run Setup Test </pre>	<p>Select Setup to enter the instrument setup routine.</p>
	<pre> </pre> <p style="text-align: center;">ENTER ↓</p>	
	<pre> SELECT EZ SETUP </pre>	<p>Press ENTER to begin EZ Setup routine.</p>
	<pre> </pre> <p style="text-align: center;">ENTER ↓</p>	
	<pre> CHANGES ALL SETUPS ! No Yes </pre>	<p>Confirm that you want to run EZ Setup. Caution: Any previous program settings may be lost or reset.</p>
	<pre> </pre> <p style="text-align: center;">ENTER ↓</p>	
	<pre> INSTRUMENT TYPE Rate/Tot Batch </pre>	<p>Instrument Type.</p>
	<pre> </pre> <p style="text-align: center;">ENTER ↓</p>	
	<pre> RATE TIME BASE Sec Min Hour Day </pre>	<p>Select the appropriate rate time base.</p>
	<pre> </pre> <p style="text-align: center;">ENTER ↓</p>	
	<pre> RATE DEC PLACES<0-4> </pre>	<p>Enter the desired rate decimal location. 0-4 decimal places allowed.</p>
	<pre> </pre> <p style="text-align: center;">ENTER ↓</p>	
	<pre> TOTAL VOLUME UNITS </pre>	<p>Enter the desired totalizer units label.</p>
	<pre> </pre> <p style="text-align: center;">ENTER ↓</p>	
<pre> TOT DEC PLACES <0-3> </pre>	<p>Enter the desired totalizer decimal location. 0-3 decimal places allowed.</p>	
<pre> </pre> <p style="text-align: center;">ENTER ↓</p>		
<pre> K_FACTOR TYPE Avg LinTbl </pre>	<p>Enter the desired K-Factor Type.</p>	
<pre> </pre> <p style="text-align: center;">ENTER ↓</p>		
<pre> AVERAGE KA-FACTOR ##### P/gal </pre>	<p>If Average selected, Enter the desired Average K-Factor.</p>	
<pre> </pre> <p style="text-align: center;">ENTER ↓</p>		
<pre> LINEAR TABLE KA Fre01:##### Hz </pre>	<p>If LinTbl selected, Enter the desired frequency/ K-Factor pair for each point in the Linearization Table.</p>	
<pre> </pre> <p style="text-align: center;">ENTER ↓</p>		
<pre> LINEAR TABLE KA KA--01:##### </pre>	<p>Enter a frequency of 0 for any point other than Fre01 to exit Linearization Table setup.</p>	
<pre> </pre> <p style="text-align: center;">ENTER ↓</p>		
<pre> FS ANALOG OUT 20mA #####gal/m </pre>	<p>Enter the desired full scale setting for the analog output.</p>	
<pre> </pre> <p style="text-align: center;">ENTER ↓</p>		
<pre> RATE 00.0 gal/m TOTAL 0 gal </pre>	<p>Return to Run Mode</p>	

Through 16 Points

6.3 SETUP MENUS

Top Level Setup Menu

Sub-menu Groups

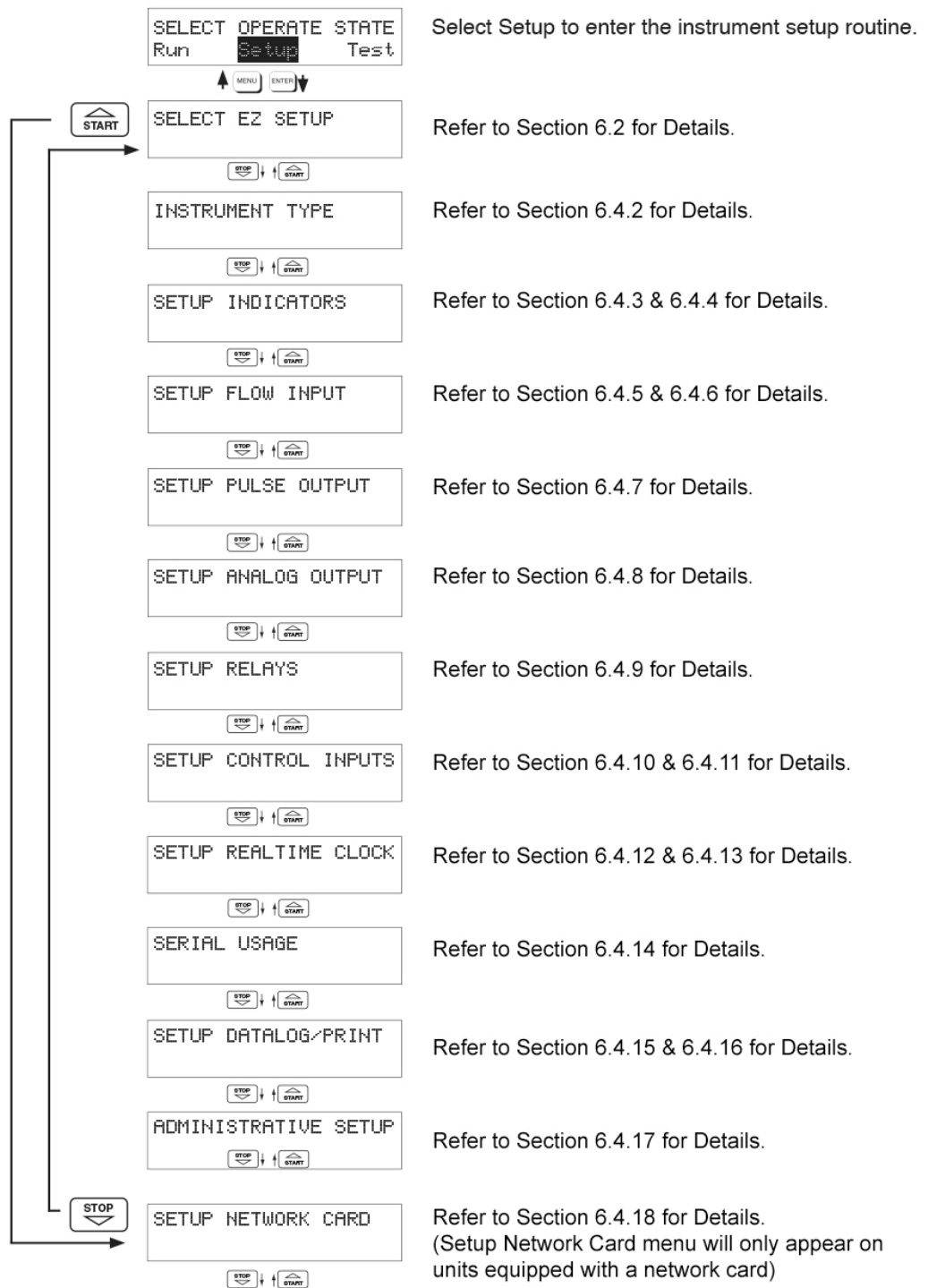

6.4 SETUP SUB-MENU

6.4.1
SELECT EZ SETUP

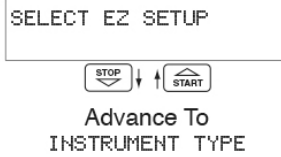

Refer to section 6.2 for EZ Setup routine.

Press the DOWN (stop) key to advance to Instrument Type. Press the UP (start) key to advance to Administrative Setup.

6.4.2
INSTRUMENT TYPE

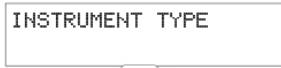

Press ENTER to enter Instrument Type sub-menus.

Rate/Tot

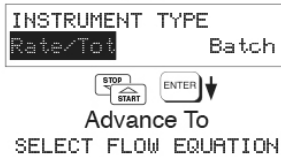

Press ENTER when Rate/Total is flashing to configure the instrument as a Ratemeter/Totalizer.

If Rate/Tot selected, advance to Setup Indicators.

Batch



Press ENTER to enter Instrument Type sub-menus.



Press ENTER when Batch is flashing to configure the instrument as a Batcher.

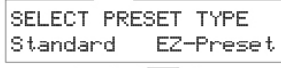

Select Standard for standard preset operation. Select EZ-Preset for quick preset editing mode. (see section 5.4.1 Batcher Configuration.)



Select UP to Reset to 0 and count up to preset. Select DOWN to reset to Preset and count down to 0.



Enter the maximum allowable Batch Preset. The operator will not be able to enter a batch preset larger than this value.



Select ON to set the unit to operate using a Batch Overrun Compensation routine. Select OFF to inhibit Batch Overrun Compensation routine.



Select On to enable the Auto Batch Restart. This will automatically restart the unit at the end of each batch run (after programmed timeout). Select Off to disable.



Enter Time Delay for Auto Batch Restart. When a batch is completed, the next batch will start automatically after the amount of time entered here has elapsed.



Enter a timeout of 0 to 99 seconds. If a batch is "Filling" and zero flow persists for more than this time, the batch filling will be stopped.



Enter time (0-99 sec.) for Max. Drain Time. After batch quantity is reached, "Batch Done" is declared when the flow rate is "0" or the Maximum Drain Time has expired.



Enter a quantity for a Slow Start up. RLY 1 (slow flow) will energize for Slow Start and RLY 2 (fast flow) will energize after the Slow Start Quantity has been delivered. Both RLY 1 and RLY 2 are energized during "fast fill".

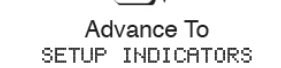

NOTE: Max Drain time value must be greater than the slowest valve response time when using Batch Overrun Comp.

<p>6.4.3 SETUP INDICATORS (Total)</p>	<pre> SETUP INDICATORS ENTER ↓ SETUP INDICATORS Total Rate ENTER ↓ TOTAL DESCRIPTOR TOTAL ENTER ↓ TOTAL VOLUME UNITS gal ENTER ↓ TOT DEC PLACES <0-3> 0 ENTER ↓ Advance To SETUP INDICATORS (Rate) </pre>	<p>Press ENTER to begin setup of the Indicators</p> <p>Press ENTER when Total is flashing to configure the Totalizer Indicators</p> <p>Enter the desired Total Descriptor text</p> <p>Enter the desired Volume Units Label text for the Totalizer.</p> <p>Select the desired Total Decimal Place. 0-3 decimal places allowed.</p>
<p>6.4.4 SETUP INDICATORS (Rate)</p>	<pre> SETUP INDICATORS Total Rate ENTER ↓ RATE TIME BASE Sec Min Hour Day ENTER ↓ RATE DESCRIPTOR RATE ENTER ↓ RATE DEC PLACES<0-4> 4 ENTER ↓ RATE AVG FILTER 0 ENTER ↓ QUICK UPDATE % 5 ENTER ↓ Advance To SETUP FLOW INPUT </pre>	<p>Press ENTER when Rate is flashing to configure the Ratemeter Indicators</p> <p>Select the desired Rate Time Base.</p> <p>Enter the desired Descriptor text for the Ratemeter.</p> <p>Select the desired Rate Decimal Place. 0-4 decimal places allowed.</p> <p>Enter desired Rate Averaging Filter. (see Definitions for more details)</p> <p>Enter desired Percent of Change for Quick Update. If the current flowrate deviates by an amount greater than the percentage value entered, the Rate Averaging is inhibited. (See Definitions for more details.)</p>

**6.4.5
SETUP FLOW INPUT**
(Pulse - chA &
chA=chB)

NOTE:
chA = Single Pulse
chA=chB = Pulse
checking
for
missing
pulses
Qx1 = Quadrature
Qx2 = Quadrature x 2

<pre> SETUP FLOW INPUT (ENTER) ↓ EXCITATION VOLTAGE 5v 12v 24v (ENTER) ↓ PULSE INPUT TYPE chA chA=chB Qx1 Qx2 (ENTER) ↓ PULSE TRIGGER LEVEL 10mV 100mV 2.5V (ENTER) ↓ LOW PASS FILTER 40Hz 3KHz 20KHz (ENTER) ↓ INPUT TERMINATION Pullup Pulldown None (ENTER) ↓ MAX WINDOW <1-99> 1 (ENTER) ↓ K_FACTOR TYPE Avg LinTbl (ENTER) ↓ AVERAGE KA-FACTOR ##### P/gal (ENTER) ↓ LINEAR TABLE KA Fre01:##### Hz LINEAR TABLE KA KA--01:##### P/gal (ENTER) ↓ LOW FLOW RATE ALARM ##### gal/m (ENTER) ↓ HIGH FLOW RATE ALARM ##### gal/m (ENTER) ↓ Advance To SETUP PULSE OUTPUT </pre>	<p>Press ENTER to begin setup of Flow Input.</p> <p>Select the desired Excitation Voltage for your flow sensor. Caution: Improper selection may cause damage to sensor</p> <p>Enter the desired Pulse type. See side note.</p> <p>Select the desired Input Pulse Trigger Level.</p> <p>Select the desired Low Pass Filter. (Max. Count Speed). Use 3kHz with turbine flowmeters.</p> <p>Select the proper input termination.</p> <p>Enter the desired Maximum Sample Window Time (1-99 sec) that can occur at the lowest flowrate. Use 1 second for turbine flowmeters.</p> <p>Enter the desired K-Factor Type.</p> <p>If Avg selected, Enter the desired Average K-Factor in the units requested.</p> <p>If LinTbl selected, Enter the desired frequency/ K-Factor pair for each point in the Linearization Table. NOTE: Enter 0 for Fre value of any point (other than Fre01) to exit the routine and use the values entered up to that point.</p> <p>Enter the desired volumetric Low Rate Alarm. This will trigger an alarm message if alarm conditions occur. The relays are not affected.</p> <p>Enter the desired volumetric High Rate Alarm. This will trigger an alarm message if alarm conditions occur. The relays are not affected.</p>
---	--

Through 16 Points

**6.4.6
SETUP FLOW INPUT**
(Pulse - Quadrature,
Qx1 or Qx2)

NOTE:
chA = Single Pulse
chA=chB = Pulse
checking
for
missing
pulses
Qx1 = Quadrature
Qx2 = Quadrature x 2

SETUP FLOW INPUT ENTER ↓	Press ENTER to begin setup of Flow Input.
EXCITATION VOLTAGE 5v 12v 24v ENTER ↓	Select the desired Excitation Voltage.
FLOW INPUT TYPE Pulse ENTER ↓	Press ENTER when Pulse is flashing to configure the flow input for Pulse signals.
PULSE INPUT TYPE chA chA=chB Qx1 Qx2 ENTER ↓	Enter the desired Pulse type. See side note.
PULSE TRIGGER LEVEL 10mV 100mV 2.5V ENTER ↓	Select the desired Input Pulse Trigger Level.
LOW PASS FILTER 40Hz 3KHz 20KHz ENTER ↓	Select the desired Low Pass Filter. (Max. Count Speed). Use 3kHz with turbine flowmeters.
INPUT TERMINATION Pullup Pulldown None ENTER ↓	Select the proper input termination.
MAX WINDOW (1-99) 1 ENTER ↓	Enter the desired Maximum Sample Window Time (1-99 sec) that can occur at the lowest flowrate. Use 1Hz for turbine flowmeters.
K_FACTOR TYPE Avg LinTbl ENTER ↓	Enter the desired K-Factor Type.
AVERAGE KA-FACTOR ##### P/gal ENTER ↓	If Avg selected, Enter the desired Average K-Factor (KA for channel A).
AVERAGE KB-FACTOR ##### P/gal ENTER ↓	Enter the desired Average K-Factor (KB for channel B).
LINEAR TABLE KA Fre01:##### Hz ENTER ↓	If LinTbl selected, Enter the desired frequency/ K-Factor pair for each point in the Linearization Table. (channel A) NOTE: Enter 0 for Fre value of any point (other than Fre01) to exit the routine and use the values entered up to that point.
LINEAR TABLE KA KA--01:##### P/gal ENTER ↓	
LINEAR TABLE KB Fre01:##### Hz ENTER ↓	Enter the desired frequency/ K-Factor pair for each point in the Linearization Table. (channel B) NOTE: Enter 0 for Fre value of any point (other than Fre01) to exit the routine and use the values entered up to that point.
LINEAR TABLE KB KA--01:##### P/gal ENTER ↓	
LOW FLOW RATE ALARM ##### gal/m ENTER ↓	Enter the desired volumetric Low Rate Alarm. This will trigger an alarm message if alarm conditions occur. The relays are not affected.
HIGH FLOW RATE ALARM ##### gal/m ENTER ↓	Enter the desired volumetric High Rate Alarm. This will trigger an alarm message if alarm conditions occur. The relays are not affected.
Advance To SETUP PULSE OUTPUT	

<p>6.4.7 SETUP PULSE OUTPUT</p>	<pre> SETUP PULSE OUTPUT (ENTER) ↓ PULSE OUTPUT USAGE Off Volume (ENTER) ↓ PULSE WIDTH 10mS 100mS (ENTER) ↓ PULSE VALUE 1000 gal/P (ENTER) ↓ Advance To SETUP ANALOG OUTPUT </pre>	<p>Press ENTER at this prompt to setup the Pulse Output.</p> <p>Select the desired Pulse Output Usage.</p> <p>Select the desired Pulse Width for the Pulse Output.</p> <p>Enter the desired Pulse Value for the Pulse Output (Volume Units per Pulse).</p>
<p>6.4.8 SETUP ANALOG OUTPUT</p>	<pre> SETUP ANALOG OUTPUT (ENTER) ↓ ANALOG OUTPUT USAGE Rate Total (ENTER) ↓ ANALOG OUTPUT RANGE 4-20mA 0-20mA (ENTER) ↓ LS ANALOG OUTPUT 0.0 gal/m (ENTER) ↓ FS ANALOG OUT 20mA 1000.0 gal/m (ENTER) ↓ ANALOG OUT DAMPING 0.0 (ENTER) ↓ Advance To SETUP RELAYS </pre>	<p>Press ENTER when Analog is flashing to setup the Analog Output.</p> <p>Select the desired Analog Output Usage.</p> <p>Select the desired current range for the Analog Output.</p> <p>Enter desired Analog Output Low Scale Value. NOTE: Units label will correspond with output usage type selected.</p> <p>Enter desired Analog Output Full Scale Value.</p> <p>Enter the desired Analog Output Damping Constant. See Definitions for additional information.</p>

**6.4.9
SETUP RELAYS**

(Relay 1 & Relay 2)

NOTE:

In Batch mode, Relay 1 is reserved for Preset, Relay 2 is reserved for Prewarn or NA (not assigned).

SETUP RELAYS

(Relay 3 & Relay 4)

NOTE:

Settings for Relays 3 & 4 may be entered even if relays are not supplied. The settings will still trigger display alarm messages if applicable.

```

SETUP RELAYS
R1y1 R1y2 R1y3 R1y4
    
```

ENTER ↓

```

RELAY 1  USAGE
RATE    TOTAL    NA
    
```

ENTER ↓

```

RELAY 1 DELAY    sec
                0
    
```

ENTER ↓

```

RELAY 1 DURATION    #####
    
```

ENTER ↓

```

RELAY 1 MODE
LO_ALARM  HI_ALARM
    
```

ENTER ↓

```

RELAY 1 SETPOINT
                ##### gal
    
```

ENTER ↓

```

RELAY 1 HYSTERESIS
                ##### gal/m
    
```

ENTER ↓

```

SETUP RELAYS
R1y1 R1y2 R1y3 R1y4
    
```

ENTER ↓

```

RELAY 3  USAGE
Rate Tot Alrm Ovr NA
    
```

ENTER ↓

```

RELAY 4  USAGE
Rate Tot Alrm NA
    
```

ENTER ↓

```

RELAY 3 DELAY    sec
                0
    
```

ENTER ↓

```

RELAY 3 DURATION    #####
    
```

ENTER ↓

```

RELAY 3 MODE
LO_ALARM  HI_ALARM
    
```

ENTER ↓

```

RELAY 3 SETPOINT
                ##### gal
    
```

ENTER ↓

```

RELAY 3 HYSTERESIS
                ##### gal/m
    
```

ENTER ↓

Advance To
SETUP CONTROL INPUTS

Select the desired Relay for setup.
(Relays 3 & 4 Optional, menus will always appear even if option not installed)

If Relay 1 or Relay 2 Selected,
Select Rate, Total or NA.

If Rate selected, enter desired relay activation delay value. Alarm condition must be continuously present for this amount of time before alarm will activate.

If Total Selected, Enter desired Relay Duration.

Select the desired Relay Activation.
Low: Relay activates when reading is below setpoint.
High: Relay activates when reading is above setpoint.

Enter the desired Setpoint. The Setpoint can be edited in run mode using the PRE 1 key (PRE 2 key for Relay 2).

If Rate, selected, Enter desired Relay Hysteresis.

Select the desired Relay for setup.
(Relays 3 & 4 Optional)

If Instrument Type is set for BATCHER,
Choose Rate, Total, Alrm, Ovr or NA.

If Instrument Type is set for RATE/TOTAL,
Choose Rate, Total, Alrm or NA.

If Rate / Alrm selected, enter desired relay activation delay value.

If Total Selected, Enter desired Relay Duration.

Select the Relay Activation for Rate/Alrm.
Low: Relay activates when reading is below setpoint.
High: Relay activates when reading is above setpoint.

Enter the desired Setpoint. The setpoint 3 can be edited in the "Run Mode" using the 4 key (9 key for Relay 4).

If Rate, selected, Enter desired Relay Hysteresis.

RELAY NOTES & CONSIDERATIONS

1. Relay activation is based on the computed readings not the displayed value. Therefore, the display damping factor will not affect the relay response time. The RELAY DELAY feature allows the user to enter a time delay for relay activation. This feature is very useful in applications where short over/under range conditions are not considered alarm conditions.
2. When INSTRUMENT TYPE is set to batcher, Relay 1 is reserved for PRESET and Relay 2 is reserved for PREWARN or NA (not assigned).
3. Setting the relays to NA (Not Assigned), will allow the relay activation to be controlled via the RS- 232 Serial port. It also allows the Presets to be used for other numeric entry values via serial commands which can be part of the print list.
4. Relay 3 and Relay 4 settings may be used to trigger display alarm conditions even if the relays are not supplied.

<p>6.4.10 SETUP CONTROL INPUTS (RATE/TOTAL)</p>	<div style="border: 1px solid black; padding: 5px; margin-bottom: 5px;"> SETUP CONTROL INPUTS ENTER ↓ </div> <p>Press Enter to begin setup of the Control Inputs.</p> <div style="border: 1px solid black; padding: 5px; margin-bottom: 5px;"> SETUP CONTROL INPUTS Input1 Input2 Input3 ENTER ↓ </div> <p>Select the desired Control Input for setup.</p> <div style="border: 1px solid black; padding: 5px; margin-bottom: 5px;"> CONTROL INPUT1 USAGE INHIBIT_TOTAL NA </div> <p>If Control Input 1 Selected, Select Inhibit Total or NA (Not Assigned).</p> <div style="border: 1px solid black; padding: 5px; margin-bottom: 5px;"> CONTROL INPUT2 USAGE RESET_TOTAL NA </div> <p>If Control Input 2 Selected, Select Reset Total or NA (Not Assigned).</p> <div style="border: 1px solid black; padding: 5px; margin-bottom: 5px;"> CONTROL INPUT3 USAGE Prn Ack KeyLk NA ENTER ↓ </div> <p>If Control Input 3 Selected, Select Prn (Print), Ack (acknowledge), KeyLk (Keylock) or NA (Not Assigned). ACK will acknowledge and clear alarms and warning messages. Note: Alarms may reassert themselves if alarm conditions are still present.</p> <p>Advance To SETUP REALTIME CLOCK</p>
<p>6.4.11 SETUP CONTROL INPUTS (BATCH)</p>	<div style="border: 1px solid black; padding: 5px; margin-bottom: 5px;"> SETUP CONTROL INPUTS Input1 Input2 Input3 ENTER ↓ </div> <p>Select the desired Control Input for setup.</p> <div style="border: 1px solid black; padding: 5px; margin-bottom: 5px;"> CONTROL INPUT1 USAGE Start Rst/Start NA </div> <p>If Control Input 1 Selected, Select Start ,Reset/Start, NA (Not Assigned).</p> <div style="border: 1px solid black; padding: 5px; margin-bottom: 5px;"> CONTROL INPUT2 USAGE Stop Stop/Rst NA </div> <p>If Control Input 2 Selected, Select Stop, Stop/Reset, NA (Not Assigned).</p> <div style="border: 1px solid black; padding: 5px; margin-bottom: 5px;"> CONTROL INPUT3 USAGE Rst Prn KeyLk Ack NA ENTER ↓ </div> <p>If Control Input 3 Selected, Select Prn (Print), Ack (acknowledge), KeyLk (Keylock) or NA (Not Assigned). ACK will acknowledge and clear alarms and warning messages. Note: Alarms may reassert themselves if alarm conditions are still present.</p> <p>Advance To SETUP REALTIME CLOCK</p>

**6.4.12
SETUP REALTIME CLOCK
(Time)**

```
SETUP REALTIME CLOCK
```

Press Enter to begin setup of the Realtime Clock.

ENTER ↓

```
SETUP REALTIME CLOCK
Time          Date
```

Select Time to set the time.

ENTER ↓

```
CLOCK TYPE
24HR          12HR
```

Select 24Hr or 12Hr clock

ENTER ↓

```
SELECT CLOCK AM/PM
AM            PM
```

If 12Hr Clock,
Enter AM or PM

ENTER ↓

```
TIME OF DAY HH:MM:SS
           ##:##:##
```

Enter time of day.

ENTER ↓

```
Advance To
SETUP REALTIME CLOCK
(Date)
```

**6.4.13
SETUP REALTIME CLOCK
(Date)**

```
SETUP REALTIME CLOCK
Time          Date
```

Select Date to enter the date.

ENTER ↓

```
DATE: MONTH, DAY, YEAR
      ##/##/####
```

Enter the date. (Month, Day, Last two digits of Year, first two digits of year will adjust accordingly)

ENTER ↓

```
Advance To
SERIAL USAGE
```

**6.4.14
SERIAL USAGE**

SERIAL USAGE

ENTER ↓

Press Enter to begin setup of the Serial Port.

SERIAL HARDWARE
RS232

ENTER ↓

Select Serial Hardware type for standard port. RS-232 is standard.

DEVICE ID ##

ENTER ↓

Select the Device ID (0-99).

BAUD RATE
300 600 1200 <more>

ENTER ↓

Select the desired Baud Rate.

BAUD RATE
2400 4800 9600 19200

ENTER ↓

(If <more> selected, additional baud rates are offered. 9600 is standard)

PARITY
None Odd Even

ENTER ↓

Select the desired Parity. (NONE is standard)

HANDSHAKING
None Software Hardware

ENTER ↓

Set the Handshake. (NONE is standard)

DEVICE LINE FEED
<CR> <CR+LF>

ENTER ↓

Choose end of line termination. Only choose <CR> if your external device automatically assigns a line feed for every <CR> carriage return.

MODEM CONTROL
No Yes

ENTER ↓

Select "Yes" if the serial port will be used to control a Hayes compatible modem.

MODEM AUTO ANSWER
No Yes

ENTER ↓

Select the desired Modem Auto Answer mode. Select YES to setup modem to answer incoming calls.

CALL OUT PHONE # 0

ENTER ↓

Enter the Call Out Phone Number to be dialed at "Call Out Time" or upon "Call On Error/Alarm".

CALL OUT TIME ##:##:##

ENTER ↓

Enter the time of day to perform Call Out transmission.

CALL ON ERROR/ALARM
No Yes

ENTER ↓

Select "Yes" to have the unit perform a Call Out transmission upon error/alarm condition.

NUMBER OF REDIALS 0

ENTER ↓

Enter the number of redials to be performed on call out time if busy or no answer. (error/alarm tries until connected)

HANGUP IF 2MIN INACT
No Yes

ENTER ↓

Select "Yes" to perform hang-up if there is inactivity for more than 2 minutes for calls initiated by the BC110.

Advance To
SETUP DATALOG/PRINT

**6.4.15
 SETUP
 DATALOG/PRINT
 (Configure)**

```

  SETUP DATALOG/PRINT
  
```

Press Enter to setup the Datalog/Print information.

ENTER ↓

```

  SETUP DATALOG/PRINT
  Config Select_list
  
```

Select Config to configure the Datalog/Print information.

ENTER ↓

```

  OUTPUT FORMAT
  Printer Term Dbase
  
```

Select the type of Output Format.

ENTER ↓

```

  PAGE LENGTH [99 max]
                99
  
```

Enter the desired Page Length.
 If Printer selected above.

ENTER ↓

```

  TOP MARGIN [99 max]
                3
  
```

Enter the desired Top Margin.
 If Printer selected above.

ENTER ↓

```

  DATALOG ONLY
  No Yes
  
```

Select Yes to record events to the datalogger only.
 Events will not be sent to the serial port. Select NO to
 output immediately and also log data.

ENTER ↓

```

  PRINT TIME HH:MM:SS
             00:00:00
  
```

Enter Print Time, printer will print at this time every day.
 Enter 00:00:00 to inhibit print time.

ENTER ↓

```

  PRINT INTERVAL
             00:00:00
  
```

Enter Print Interval, (HH:MM:SS)
 Enter 00:00:00 to inhibit print interval.

ENTER ↓

```

  ENABLE PRINT KEY
  NO YES
  
```

Select YES to enable Print Key.
 Select NO to disable Print Key.

ENTER ↓

```

  PRINT END OF BATCH
  NO YES
  
```

Batch mode only.
 Select Yes to print at end of batch.

ENTER ↓

```

  Advance To
  SETUP DATALOG/PRINT
  (Select_list)
  
```

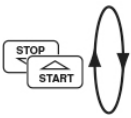
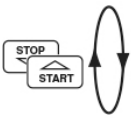
<p>6.4.16 SETUP DATALOG/PRINT (Select_list)</p> <p>List Items:</p> <ul style="list-style-type: none"> TOTAL RATE PRE1 PRE3 GRAND PRE2 PRE4 TIME 	<div style="display: flex; align-items: center;"> <div style="margin-right: 20px;">  </div> <div style="flex-grow: 1;"> <div style="border: 1px solid black; padding: 5px; margin-bottom: 5px;">SET DATALOG/PRINT</div> <div style="text-align: center; margin-bottom: 5px;">ENTER ↓</div> <div style="border: 1px solid black; padding: 5px; margin-bottom: 5px;">SET DATALOG/PRINT Config Select_list</div> <div style="text-align: center; margin-bottom: 5px;">ENTER ↓</div> <div style="border: 1px solid black; padding: 5px; margin-bottom: 5px;">PRINT LIST ITEMS TOTAL YES</div> <div style="text-align: center; margin-bottom: 5px;">ENTER ↓</div> <div style="border: 1px solid black; padding: 5px; margin-bottom: 5px;">PRINT LIST ITEMS RATE YES</div> <div style="text-align: center; margin-bottom: 5px;">ENTER ↓</div> <div style="border: 1px solid black; padding: 5px; margin-bottom: 5px;">PRINT LIST ITEMS PRE 1 YES</div> <div style="text-align: center; margin-bottom: 5px;">ENTER ↓</div> <div style="border: 1px solid black; padding: 5px; margin-bottom: 5px;">PRINT LIST ITEMS DataLog size =001489</div> <div style="text-align: center; margin-bottom: 5px;">ENTER ↓</div> <p style="text-align: center;">Advance To ADMINISTRATIVE SETUP</p> </div> </div> <div style="margin-top: 20px;"> <p>Press enter to begin Setup Datalog/Print routine.</p> <p>Press enter when Select_list is selected to setup print list.</p> <p>Use Up and Down arrow keys to view list status. Press the PRINT key to add or remove items from the list. Items marked with Yes will be added to the list, items marked with No will be removed from the list. Press ENTER to accept list when ready</p> <p>The Select Print List Information display shows the current possible Datalog size after your list has been entered.</p> </div>
<p>6.4.17 ADMINISTRATIVE SETUP</p> <p>NOTE: Accessed only with supervisor password.</p>	<div style="display: flex; align-items: center;"> <div style="margin-right: 20px;">  </div> <div style="flex-grow: 1;"> <div style="border: 1px solid black; padding: 5px; margin-bottom: 5px;">ADMINISTRATIVE SETUP</div> <div style="text-align: center; margin-bottom: 5px;">ENTER ↓</div> <div style="border: 1px solid black; padding: 5px; margin-bottom: 5px;">OPERATOR PASSWORD *****</div> <div style="text-align: center; margin-bottom: 5px;">ENTER ↓</div> <div style="border: 1px solid black; padding: 5px; margin-bottom: 5px;">SUPERVISOR PASSWORD *****</div> <div style="text-align: center; margin-bottom: 5px;">ENTER ↓</div> <div style="border: 1px solid black; padding: 5px; margin-bottom: 5px;">SOFTWARE VERSION Vxx.xxx</div> <div style="text-align: center; margin-bottom: 5px;">ENTER ↓</div> <div style="border: 1px solid black; padding: 5px; margin-bottom: 5px;">PRODUCT ORDER CODE SL90xxxxxxxx</div> <div style="text-align: center; margin-bottom: 5px;">ENTER ↓</div> <div style="border: 1px solid black; padding: 5px; margin-bottom: 5px;">UNIT SERIAL NUMBER 00000</div> <div style="text-align: center; margin-bottom: 5px;">ENTER ↓</div> <div style="border: 1px solid black; padding: 5px; margin-bottom: 5px;">SENSOR SERIAL NUMBER 00000</div> <div style="text-align: center; margin-bottom: 5px;">ENTER ↓</div> <p style="text-align: center;">Advance To SETUP NETWORK CARD</p> </div> </div> <div style="margin-top: 20px;"> <p>Press Enter to begin Administrative Setup.</p> <p>Enter Operator Password. (Factory Set to 0) Define a nonzero value for each unit to lock unit and prevent accidental menu changes.</p> <p>Enter Supervisor Password. (Factory Set to 2000)</p> <p>This display is used to show the software version of the installed software.</p> <p>This display is used to show the product order code (model number). Factory set.</p> <p>This display is used to show the unit's serial number. Factory set.</p> <p>This display is used to edit and show the sensor's serial number.</p> </div>

**6.4.18
SETUP NETWORK
CARD**
(optional)

SETUP NETWORK CARD

Press Enter to setup Network Card.

ENTER ↓

SELECT NETW PROTOCOL
Mod

Select desired Network Protocol. (only Modbus RTU is supported)

ENTER ↓

NETWORK DEVICE ID
1

Enter the device address on network (00-247).

ENTER ↓

BAUD RATE
2400 4800 9600 19200

Select the desired Baud Rate.

ENTER ↓

PARITY
None Odd Even

Select the desired Parity.

ENTER ↓

Advance To
DO EZ SETUP?

7 PRINCIPALS OF OPERATION

7.1 GENERAL:

The BC110 Flow Computer uses several internal calculations to compute the input frequency based on specific data input. Several computations are performed to yield flow or linearized flow.

7.2 FLOW EQUATIONS:

Uncompensated Flow Computation:

Pulse Input; Average K-Factor

Volume Flow = (input frequency • time scale factor) / K-Factor

Pulse Input; Linear Table

Volume Flow = (input frequency • time scale factor) / K-Factor (Hz)

Where K-Factor (Hz) is the K-Factor returned at frequency (Hz) from interpolation of the 16 point table.

7.3 LINEARIZATION TABLE

7.3.1 Linearization Table General Information

The Linearization Table is used when the flow input device gives a nonlinear input signal. The unit uses up to 16 different points, as entered by the operator, to form a curve for linearizing the input signal.

Notes:

- 1) A minimum of three points must be set up.
- 2) If "0" is entered for the frequency of any point other than point 1, the Flow Computer assumes there are no more points above the points that preceded them. The display will advance to the next setup prompt.
- 3) If the input frequency is above the highest or below the lowest frequency programmed, the unit will use the last known point for the K factor in computing the resulting actual flow.
- 4) Frequency- Point pairs should be entered in ascending order of frequency.

7.3.2 Linearization Table for Pulse Inputs

The linearization table for pulse inputs programming is quite simple when values of frequency and K-Factors are known. The Flow Computer asks for 16 different frequencies (Freq) and 16 corresponding K factors (K). It then uses this data to determine what the actual flow is for any given input frequency. Usually the necessary data is provided with the flowmeter.

7.3.3 Linearization Table Interpolation

The Linearization Table routine uses the entered data to determine the K factor for any given input frequency signal. This is done by taking the closest data points above and below the input signal, then using those points to interpolate the K factor (correction factor), then calculating the flow from the data. Below are the formulas.

Parameters:

Determine closest point above input signal signal = X,
K factor (correction factor) = KA

Determine closest point below input signal signal = Y,
K factor (correction factor) = KB

Let input signal = H, unknown K factor (correction factor) = KN

To find KN use this formula: $((H-Y)/(X-Y)) \times (KA-KB) + KB = KN$

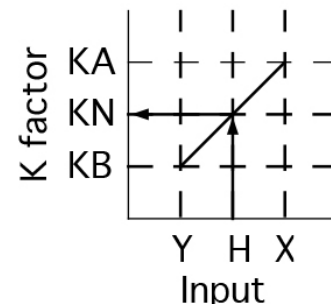

8 TEST, SERVICE AND MAINTENANCE

8.1 TEST MENUS

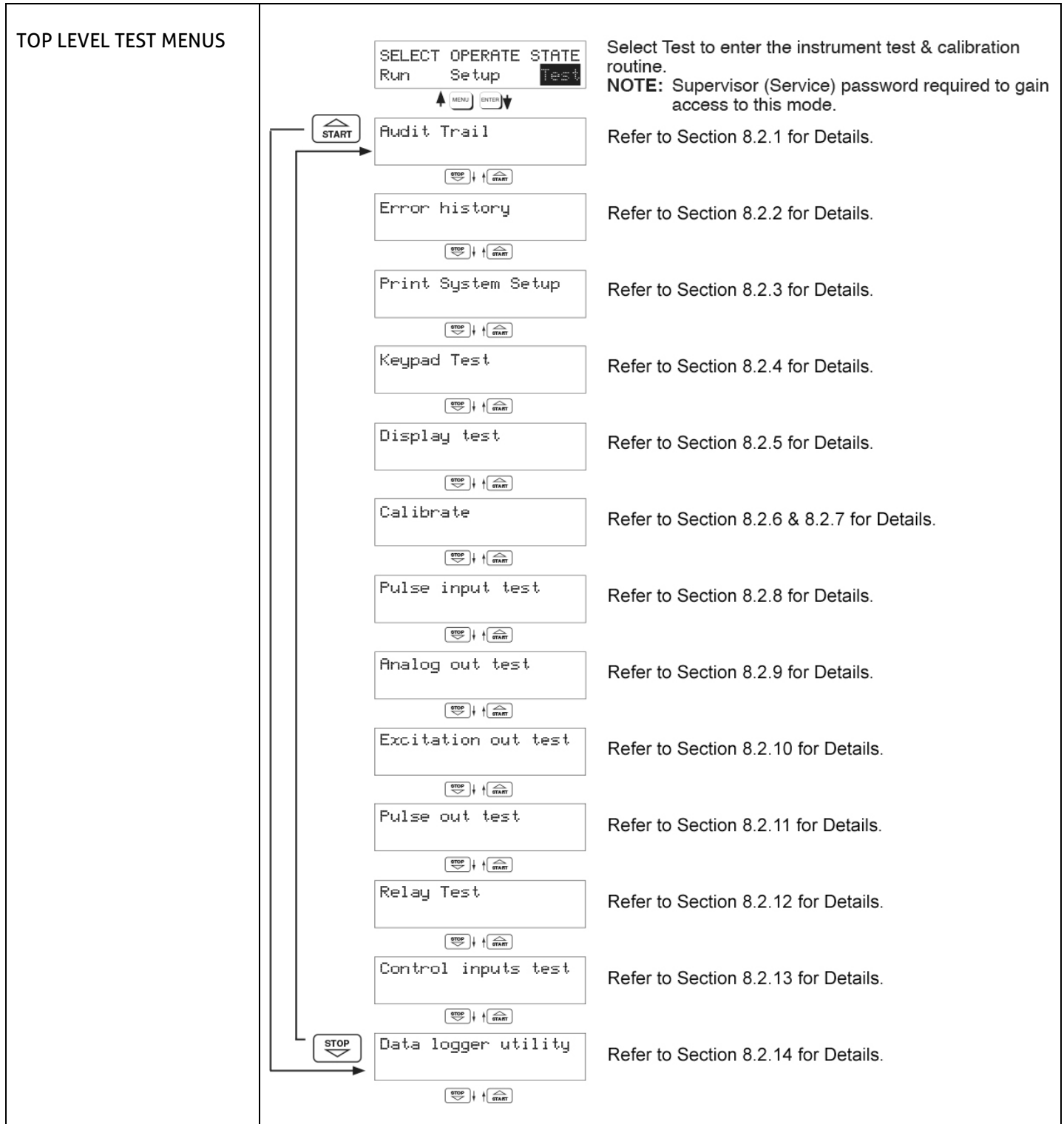

8.2 TEST SUB-MENUS

<p>8.2.1 Audit Trail</p>	<pre>Audit Trail ENTER ↓ Config_Audit nnnnn hh:mm:ss mm/dd/yy ENTER ↓ Cal_Audit nnnnn hh:mm:ss mm/dd/yy ENTER ↓ Audit Trail</pre>	<p>Press Enter to view the audit trail information.</p> <p>The configuration audit trail format: nnnnn= number of critical menu changes, hh:mm:ss; mm/dd/yy = time and date of last change.</p> <p>The calibration audit trail format: nnnnn= number of calibration changes, hh:mm:ss; mm/dd/yy = time and date of last change.</p> <p>Press Menu to get back to audit trail top-level menu.</p>
<p>8.2.2 Error History</p>	<pre>Error history ENTER ↓ Error history Flow rate alarm low ENTER ↓ Error history</pre>	<p>Press Enter to view error history. NOTE: Press Print Key to print Error History. Printout will include time/date of each errors first occurrence.</p> <p>Press Up/Down arrow keys to scroll through error message history. Press CLEAR to clear entire error log.</p> <p>Press Menu to get back to error history top-level menu.</p>
<p>8.2.3 Print System Setup</p>	<pre>Print System Setup ENTER ↓ Print System Setup Press ENTER to print ENTER ↓ Print System Setup -- Printing --- ENTER ↓ Print System Setup</pre>	<p>Press enter key to enter print system setup Sub-menu.</p> <p>Press enter to begin printing the system setup.</p> <p>This message will display as the data transmission takes place.</p> <p>Press Menu to get back to print system setup top-level menu.</p>

<p>8.2.4 Keypad test</p>	<div style="border: 1px solid black; padding: 2px; margin-bottom: 5px;">Keypad test</div> <div style="text-align: center; margin-bottom: 5px;">ENTER ↓</div> <div style="border: 1px solid black; padding: 2px; margin-bottom: 5px;">Keypad test Key pressed-> ENTER</div> <div style="text-align: center; margin-bottom: 5px;">ENTER ↓</div> <div style="border: 1px solid black; padding: 2px;">Keypad test</div>	<p>Press Enter to enter keypad test.</p> <p>Press the various keys and the display will show the key that was pressed. Press Menu to exit the test.</p> <p>Press Menu to get back to Keypad test top-level menu.</p>
<p>8.2.5 Display test</p>	<div style="border: 1px solid black; padding: 2px; margin-bottom: 5px;">Display test</div> <div style="text-align: center; margin-bottom: 5px;">ENTER ↓</div> <div style="border: 1px solid black; padding: 2px; margin-bottom: 5px;">00000000000000000000 00000000000000000000</div> <div style="text-align: center; margin-bottom: 5px;">ENTER ↓</div> <div style="border: 1px solid black; padding: 2px;">Display test</div>	<p>Press Enter to enter display test.</p> <p>Upon pressing enter the each digit on the display will scroll 0-9 then A-Z. Press menu to exit the test.</p> <p>Press Menu to get back to Display test top-level menu.</p>
<p>8.2.6 Calibrate 0 mA Out</p>	<div style="border: 1px solid black; padding: 2px; margin-bottom: 5px;">Calibrate</div> <div style="text-align: center; margin-bottom: 5px;">ENTER ↓</div> <div style="border: 1px solid black; padding: 2px; margin-bottom: 5px;">Calibrate 0mA out + TB1-15 - TB1-16</div> <div style="text-align: center; margin-bottom: 5px;">ENTER ↓</div> <div style="border: 1px solid black; padding: 2px; margin-bottom: 5px;">Calibrate 0mA out Enter mA: 0.00000</div> <div style="text-align: center; margin-bottom: 5px;">ENTER ↓</div> <div style="border: 1px solid black; padding: 2px; margin-bottom: 5px;">Calibrate 0mA out + TB1-15 - TB1-16</div> <div style="text-align: center; margin-bottom: 5px;">ENTER ↓</div>	<p>Calibrate Sub-menu group.</p> <p>Connect ammeter to (+) TB1-15, (-) TB1-16. Press enter.</p> <p>To trim 0mA output: Press CLEAR to enable editing and enter a small negative number (i.e. -0.100) to force a display reading, then clear and enter small quantity measured on your meter.</p> <p>The display will return to Calibrate 0mA out. Press the down arrow key to advance to Cal. 20mA out or repeat above if necessary.</p>
<p>8.2.7 Calibrate 20mA Out</p>	<div style="border: 1px solid black; padding: 2px; margin-bottom: 5px;">Calibrate 20mA out + TB1-15 - TB1-16</div> <div style="text-align: center; margin-bottom: 5px;">ENTER ↓</div> <div style="border: 1px solid black; padding: 2px; margin-bottom: 5px;">Calibrate 20mA out Enter mA: 20.00000</div> <div style="text-align: center; margin-bottom: 5px;">ENTER ↓</div> <div style="border: 1px solid black; padding: 2px; margin-bottom: 5px;">Calibrate 20mA out + TB1-15 - TB1-16</div> <div style="text-align: center; margin-bottom: 5px;">ENTER ↓</div> <div style="border: 1px solid black; padding: 2px;">Calibrate</div>	<p>Connect ammeter to (+) TB1-15, (-) TB1-16. Press enter.</p> <p>To trim 20mA output: Press CLEAR to enable editing and enter the current reading that is on the ammeter display. Press enter.</p> <p>The display will automatically return to the Calibrate 20mA out Sub-menu. Calibration is complete.</p> <p>Press the Menu key to go back to Calibrate top-level menu.</p>

<p>8.2.8 Pulse input test</p>		<p>Press Enter key to test the pulse input.</p> <p>Use the Up/Down arrow keys to select the appropriate trigger level.</p> <p>Use the Up/Down arrow keys to select the appropriate frequency range.</p> <p>To check Pulse input accuracy: Use TB1-4 as reference ground, input a frequency F1 on TB1-2, frequency F2 on TB1-3. The display should show frequency being input. Use a frequency counter to verify input.</p> <p>Press Menu key to return to Pulse input test top-level menu.</p>
<p>8.2.9 Analog out test</p>		<p>Press Enter to test the analog output.</p> <p>To simulate analog output: Connect an ammeter to (+) TB1-15, (-) TB1-16. Press the key under the desired current setting to move the asterisk (*). The unit should output the selected current.</p> <p>Press Menu key to return to Analog out test top-level menu.</p>
<p>8.2.10 Excitation out test</p>		<p>Press Enter to test the excitation output.</p> <p>To test the excitation output: Connect a voltmeter to (+) TB1-1, (-) TB1-4. Press the key under the desired voltage setting to move the asterisk (*). The unit should output the selected voltage.</p> <p>Press Menu key to return to Excitation out test top-level menu.</p>
<p>8.2.11 Pulse out test</p>		<p>Press Enter key to test the pulse output.</p> <p>To simulate a frequency on the pulse output: Connect a frequency counter to (+)TB1-13, (-)TB1-14. Press the key under the desired frequency setting to move the asterisk (*). The unit should output the selected frequency.</p> <p>Press Menu key to return to Pulse out test top-level menu.</p>

<p>8.2.12 Relay test</p>	<pre>Relay Test ENTER ↓ Rly1 Rly2 Rly3 Rly4 Off Off Off Off ENTER ↓ Relay Test</pre>	<p>Press Enter to test the relays.</p> <p>To manually control the relay outputs: Press the key under the desired relay to toggle the relays On/Off. Use an ohmmeter to check the relay contacts.</p> <p>Press Menu key to return to Relay Test top-level menu.</p>
<p>8.2.13 Control inputs test</p>	<pre>Control inputs test ENTER ↓ TB1-9 TB1-10 TB1-11 Off Off Off ENTER ↓ Control inputs test</pre>	<p>Press Enter to test the control inputs.</p> <p>To check the control inputs: Use TB1-12 as reference, input a DC voltage (4-24VDC) signal to TB1-9, TB1-10 and/or TB1-11, The Display will show ON when input is active, OFF when inactive.</p> <p>Press Menu key to return to control input test top-level menu.</p>
<p>8.2.14 Data logger utility</p>	<pre>Data logger utility ENTER ↓ Data logger utility Log 10 958 Max ENTER ↓ Data logger utility Log 00001 PRT CLR ENTER ↓ Data logger utility</pre>	<p>Press Enter to access data logger utility.</p> <p>The displays shows the number of Data Logs. Press the Down arrow key to advance to PRT (print) or CLR (clear) to clear datalog contents.</p> <p>Press PRINT key to output data logger logs to printer. Press CLEAR key to clear the data logger contents.</p> <p>Press Menu key to return to Data logger utility top-level menu.</p>

8.3 INTERNAL FUSE REPLACEMENT

Instructions:

1. Make sure you follow proper E.S.D. Precautions. All persons performing this replacement must follow proper grounding procedures.
2. Turn the power to the unit off.
3. Disconnect the two-piece connector rear terminal block, leaving all connections in place.
4. Remove the unit from the panel.
5. Remove the four machine screws (see fig. 1) which hold the two sections of the case together.
6. The rear section of the case should detach from the rest of the case. With the rear section of the case removed the fuse will be exposed (located near the rear terminal, AC connection).
7. Locate the Fuse F1 (see fig. 2) and unplug the fuse from its socket.
8. Insert the new fuse into the socket. Insure that the pins are fully inserted and straight.
9. Reassemble the case and install the four machine screws which join the two sections of the case.
10. Reinstall the unit into the panel.
11. Reconnect the rear terminal block.
12. Turn the unit back on.

Fuse Specifications:

110 VAC Power: 160mA/250V, TD Wickman 19372-030-k or equivalent

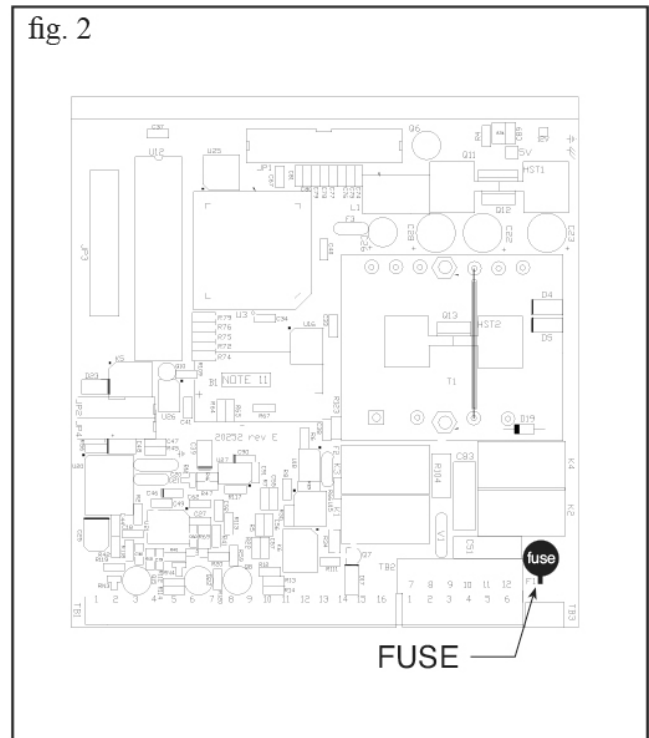
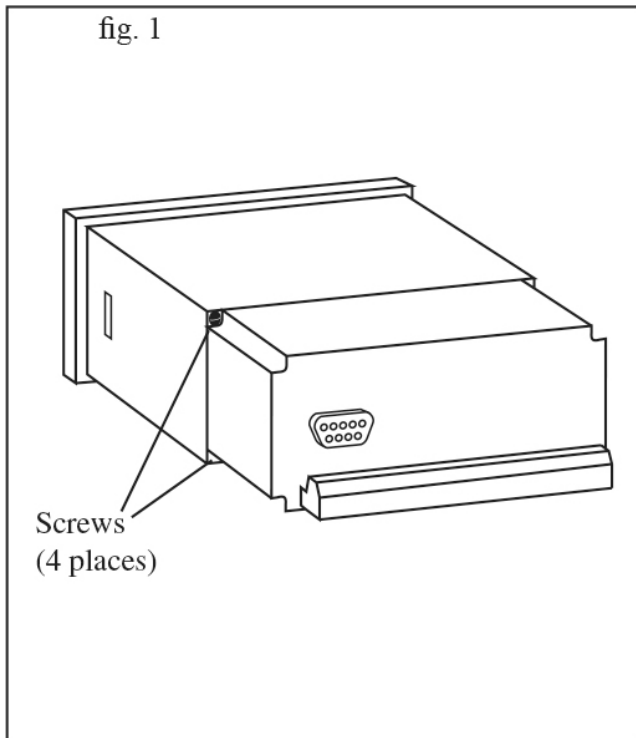

9 RS-232 SERIAL PORT

9.1 RS-232 PORT DESCRIPTION:

The BC110 has a general purpose RS-232 Port which may be used for any one of the following purposes:

Transaction Printing

Data Logging

Remote Metering by Modem (optional) Computer Communication Link Configuration by Computer

Print System Setup

Print Calibration/Malfunction History

9.2 INSTRUMENT SETUP BY PC'S OVER SERIAL PORT

A Diskette program is provided with the BC110 that enables the user to rapidly configure the BC110 using a Personal Computer. Included on the diskette are common instrument applications which may be used as a starting point for your application. This permits the user to have an excellent starting point and helps speed the user through the instrument setup.

9.3 OPERATION OF SERIAL COMMUNICATION PORT WITH PRINTERS

BC110's RS-232 channel supports a number of operating modes. One of these modes is intended to support operation with a printer in metering applications requiring transaction printing, data logging and/or printing of calibration and maintenance reports.

For transaction printing, the user defines the items to be included in the printed document. The user can also select what initiates the transaction print generated as part of the setup of the instrument. The transaction document may be initiated via a front panel key depression, a remote contact closure, or upon completion of a batch.

In data logging, the user defines the items to be included in each data log as a print list. The user can also select when or how often he wishes a data log to be made. This is done during the setup of the instrument as either a time of day or as a time interval between logging.

The system setup and maintenance report list all the instrument setup parameters and usage for the current instrument configuration. In addition, the Audit trail information is presented as well as a status report listing any observed malfunctions which have not been corrected.

The user initiates the printing of this report at a designated point in the menu by pressing the print key on the front panel.

9.4 BC110 RS-232 PORT PINOUT

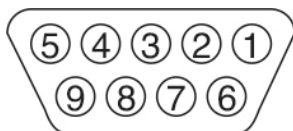

1. Printer Handshake Line or DCD In
2. Transmit (Out)
3. Receive (In)
4. N/C or Opt. Modem Power Out (7.5V)
5. Ground
6. N/C or Opt. Modem Power Out (7.5V)
7. RTS (Loop Back To CTS Only)
8. CTS (Loop Back To RTS Only)
9. N/C (No Connection)

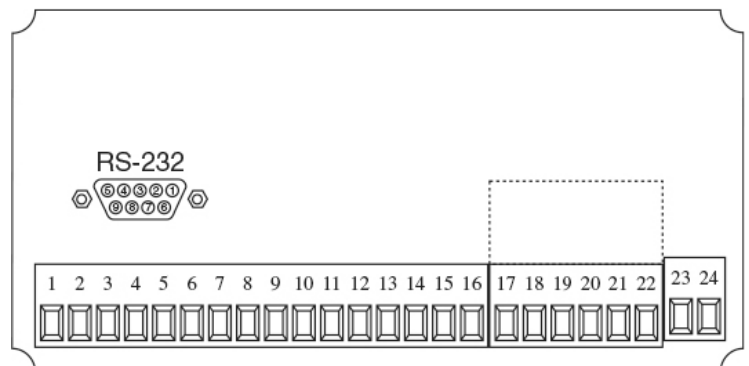

10 GLOSSARY OF TERMS

Acknowledge & Clear Alarms

Acknowledge is used to clear alarm relays and remove any visual alarm messages from the display. In the run mode, press the ENTER key or activate CONTROL INPUT 3 (if set for ACK) to momentarily clear alarms and alarm messages. Alarms will reassert themselves if alarm conditions are still present.

Analog Output

The analog signal (4-20mA) that is generated by the BC110. It can correspond to the Rate or Total. This output is used primarily for transmission of process information to remote systems.

Audit Trail

The audit trail is used to track the number of changes made to the unit's setup program and calibration.

Auto Batch Restart

The Auto Batch Restart function allows the user to set an amount of time to automatically restart a batch after the completion of a batch. This time can be set from 1 to 99 seconds.

Batch Count Mode

Batch Count Mode specifies the user preference for count direction. The "Up" selection begins with a value of "0" and counts up until the batch size is reached. The "Down" selection begins with a value equal to the desired batch size and counts down to "0".

Batch Overrun

The BC110 offers a batch overrun compensation routine. If batch overrun occurs due to slow valve response time, the unit will compensate for the overrun amount on the next batch. This feature can be disabled if desired. NOTE: A nonzero MAX DRAIN TIME value is also required.

Batcher

An instrument which controls the dispensing of desired batch amounts. Liquid batching systems are usually comprised of a batch controller (batcher), flowmeter and control valve. The batcher opens and closes the valve through the use of relays and measures the amounts of liquid being dispensed via the flowmeter.

Baud Rate

The speed of serial communication transmissions, expressed in bits per second.

Custody Transfer

Weights and Measure metering codes often specify several requirements for instruments and mechanisms to prevent and track changes in the setup of an instrument which may be used in the commercial sale of goods. The BC110 tracks changes via the Audit Trail.

Data Logger

The capturing of information for later use and the mechanism for specifying the conditions where a capture should be made.

DC Output / Excitation Voltage

An on-board DC power supply used to power peripheral sensors. The BC110 offers excitation voltages of 5VDC, 12VDC or 24VDC when powered by AC voltage.

Default Value

The value to be used by the instrument if a sensor failure or out of range signal is detected.

EZ Setup

A utility that provides for rapid configuration of an instrument. The BC110 EZ Setup provides the following:

- Prompts the user for only critical information.
- Automatically sets specifications to common uses.

After following the EZ Setup procedure, the unit will be operational to perform the basic measurement. The setup can be further customized using the setup menus.

Flow Alarm

A visual indication that the volumetric flowrate is above or below the flow alarm set point specified by the user.

Flow Signal Timeout

The Flow Signal Timeout allows the user to enter a timeout of 0 to 99 seconds. If a batch is "Filling" and zero flow persists for more than the user entered time then the batch will be aborted. This prevents over flows due to faulty flow sensors and/or wiring.

Flow Equation

A flow control expression or algorithm describing a mathematical equation to be solved by a flow computer in the desired application.

Follow Alarm

Alarm relays which are non-latching and whose output state is based solely on the comparison of the current process value, the alarm set point (trip point) and hysteresis.

Function Key

A key on a push-button panel or keyboard (whose function is described by the key label) used to perform an instrument function or special routine.

Handshake

A means of controlling the information flow between two pieces of equipment to prevent the sending device from transmitting information at a rate faster than what can be accepted by the receiver.

Hysteresis

The relay hysteresis is a "dead band" setting which allows the relay to remain energized for a given amount below the set point. This is used to prevent relay chatter when the process value is near the set point value.

Example: If the Preset is set at 100, and the hysteresis is set at 10, the relay will energize when the rate, temp or dens. reaches 100, the relay will remain energized until the reading falls below 90.

Input Termination

Input signal lines on digital inputs often require pullup or pulldown resistor configurations to operate properly with different sensor configurations. The BC110 contains such resistors and may be enabled via the setup menu.

Inhibit Totalizer

"Inhibit Total" is a Control Input 1 setting that is used to stop the totalization. If enabled, a voltage level on control input 1 will inhibit the total as long as the voltage is present. This feature is useful during meter proving and in applications that provide a sensor to signal the flow computer when liquid is present.

K-Factor

A scaling factor derived from the pulses produced by a flowmeter output, expressed in pulses per unit (i.e. pulses/gallon)

LCD

Abbreviation for: Liquid Crystal Display

Limit Set point

An alarm trip point setting which specifies the value or magnitude of a process parameter necessary to activate an alarm indicator or control relay.

Linear Flowmeter

A flow measurement device whose output is proportional to flow.

Linearization

The mathematical correction of a nonlinear device. The BC110 uses a linearization Table which is made up of input frequency and K-Factor values and makes interpolations of the table to arrive at a "linearized" measurement.

LinTbl

Abbreviation for Linearization Table.

Low Flow Cutoff

A value set at which any flow measurements read below this value will be ignored.

Low Pass Filter

A low pass filter passes low input frequencies while blocking high frequencies. In the BC110, this is the maximum input count speed to be encountered in an application. It is expressed in counts per second (Hz).

Maximum Batch Preset

The Maximum Batch Preset allows the user to program the Maximum Batch value allowed to be entered by the operator. If an operator should try to program a batch higher than this value, the unit will not allow the value to be entered and will prompt the user with an error message saying that the Maximum Batch Preset has been exceeded.

Maximum Drain Time

The unit declares that a batch is "done" when the flow rate equals "0". A flow rate may be present long after the Preset Relay de-energizes due to slow reacting valves or leaky valves. The Maximum Drain Time allows the user to enter an amount of time (0 to 99 seconds) to wait before declaring "Batch Done". After the Preset Batch quantity is reached, the unit will declare "Batch Done" when the flow rate is "0" or the Maximum Drain Time has expired. The batch data will then be available for printing and datalogging.

NOTE: A nonzero MAX DRAIN TIME value must be entered when using batch overrun compensation.

Max Window

The max. window time sets the maximum sample time (1 to 99 sec) for the ratemeter.

Operator Code

An operator password code which authorizes changes to the setup of the instrument but blocks access to the Service/Calibration/Test mode. The operator code also blocks the clearing of the Grand Total.

Parity

A method for detecting errors in transmissions of serial communications data.

Preset

A set point used to trigger the relay outputs of the BC110.

Print Interval

The print interval allows the BC110 to transmit information to the serial port at selectable time intervals.

Process Parameters

Any sensor information which has been scaled to engineering units including Flow, Temperature and Density.

Pulldown (Input Termination)

The termination of an input at which the input is pulled down to ground through a resistor. Inputs that are terminated by this method need to be driven high with a positive voltage pulse.

Pullup (Input Termination)

The termination of an input at which the input is pulled up to a positive voltage through a resistor. Inputs that are terminated by this method need to be pulled low with a sinking current or contact to ground.

Pulse Output

The pulse output of the BC110 is available for remote accumulation of the total or sent to peripheral devices, such as a PLC. The output can be scaled using the Pulse Output Scaling Constant.

Quad

Abbreviation for Quadrature. Quadrature signals are used for direction control. Two flowmeter signals are output with a 90° phase shift. The counter counts UP when channel A precedes channel B, and counts DOWN when Channel A lags Channel B.

Quick Update %

This feature is used to disable the rate averaging filter when a significant change in the flow rate occurs. The user can enter the percent of change needed to be detected to disable the averaging feature. This is especially useful during start-up and shutdown of flow.

Rate Averaging Filter

The rate averaging filter is used to stabilize fluctuating rate displays. Higher settings provide more averaging for a more stable display. Derived from the equation:

Ratometer

Any device used to display the speed of a process. The ratemeter in the BC110 displays flow rate.

Reset/Start Control Input

In a batching system, a single operator activation of the START key or Control Input 1 will reset the total then start the batch process.

Select Preset Type

This menu selection allows the user to choose between Standard Preset or EZ Preset. Select Standard for standard preset operation. Select EZ-Preset for quick preset editing mode. (see section 5.4.1 Batch Configuration.)

Single Pulse

The Single Pulse setting is used for flowmeters with single pulse outputs.

Slow Start Quantity

The Slow Start Quantity is a function that allows an amount to be entered for a Slow Start up. This function requires two stage valve control. RLY 1 (slow flow) will energize for Slow Start and RLY 2 (fast flow) will energize after the Slow Start Quantity has been delivered. This helps reduce turbulence when filling an empty container.

Stop/Reset Control Input

In a batching system, a single operator activation of the STOP key or Control Input 2 will stop the batch process then reset the total.

Totalizer

Any device which accumulates and displays a total count.

Volume Flow

The measurement of volumetric flow.

11 DIAGNOSIS AND TROUBLESHOOTING

11.1 RESPONSE OF BC110 ON ERROR OR ALARM:

Error and warning indications which occur during operation are indicated in the RUN mode alternately with the measured values. The BC110 Flow Computer has three types of error:

TYPE OF ERROR	DESCRIPTION
Sensor/Process Alarms	Errors detected due to sensor failure or process alarm conditions
Self Test Errors	Errors detected during self test.
System Alarms	Errors detected due to system failure

Some alarms are self clearing. Other alarms require the user to acknowledge and clear the alarm. Press the ENTER button to acknowledged and clear alarms. Alarms may reassert themselves if the alarm condition is still present.

NOTE: A historical error alarm log is available in the "Test Mode".

The following descriptions suggest possible causes and corrective actions for each alarm message.

11.2 DIAGNOSIS FLOW CHART AND TROUBLESHOOTING

All instruments undergo various stages of quality control during production. The last of these stages is a complete calibration carried out on state-of-the-art calibration rigs. A summary of possible causes is given below to help you identify faults.

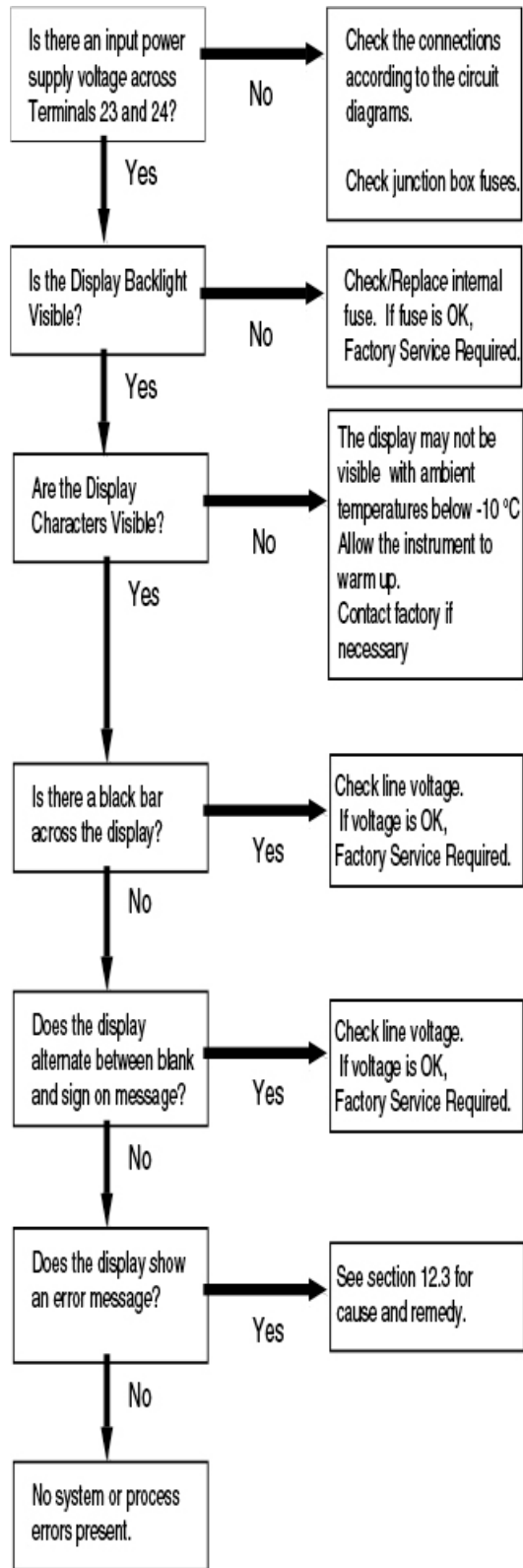

11.3 ERROR & WARNING MESSAGES:

<p>11.3.1 Sensor/Process Alarms</p>	<table border="1"> <thead> <tr> <th data-bbox="493 239 829 285">Error/Warning Message</th> <th data-bbox="829 239 1182 285">Cause</th> <th data-bbox="1182 239 1448 285">Remedy</th> </tr> </thead> <tbody> <tr> <td data-bbox="493 285 829 359">TOTALIZER ROLLOVER</td> <td data-bbox="829 285 1182 359">Displayed when totalizer rolls over</td> <td data-bbox="1182 285 1448 359"> <ul style="list-style-type: none"> • Acknowledge Rollover • Remedy not required </td> </tr> <tr> <td data-bbox="493 359 829 480">RATE OVERFLOW ERROR</td> <td data-bbox="829 359 1182 480">Pulse counter overflowed. The totalizer may have lost counts.</td> <td data-bbox="1182 359 1448 480"> <ul style="list-style-type: none"> • Report error to factory • Check application conditions • Check wiring </td> </tr> <tr> <td data-bbox="493 480 829 602">PULSE OUT OVERFLOW</td> <td data-bbox="829 480 1182 602"> Calculated pulse frequency too large: <ul style="list-style-type: none"> • Pulse width setting too long • Larger pulse scaler needed </td> <td data-bbox="1182 480 1448 602"> <ul style="list-style-type: none"> • Adjust pulse value • Adjust pulse width • Check process conditions </td> </tr> <tr> <td data-bbox="493 602 829 745">FLOW RATE ALARM LOW FLOW RATE ALARM HIGH</td> <td data-bbox="829 602 1182 745">Limit value exceeded.</td> <td data-bbox="1182 602 1448 745"> <ul style="list-style-type: none"> • Check application if necessary • Check limit value • Adjust the limit value if required </td> </tr> <tr> <td data-bbox="493 745 829 913">BATCH OVERRUN ALARM</td> <td data-bbox="829 745 1182 913">Batch size exceeded by more than set limit.</td> <td data-bbox="1182 745 1448 913"> <ul style="list-style-type: none"> • Check valves in system for proper operation and/or leaks • Check limit value • Adjust the limit value if required </td> </tr> <tr> <td data-bbox="493 913 829 1081">MODEM NOT PRESENT</td> <td data-bbox="829 913 1182 1081">The setup expects modem usage and a modem is not responding.</td> <td data-bbox="1182 913 1448 1081"> <ul style="list-style-type: none"> • Check setup for proper baud rate, parity, etc. • Check modem connection and cycle power to ST1LE • Replace modem </td> </tr> <tr> <td data-bbox="493 1081 829 1127">SOFTWARE ERROR RESET</td> <td data-bbox="829 1081 1182 1127">Software error</td> <td data-bbox="1182 1081 1448 1127"> <ul style="list-style-type: none"> • Report error to factory </td> </tr> <tr> <td data-bbox="493 1127 829 1346">EXTENDED PFI LOCKUP</td> <td data-bbox="829 1127 1182 1346">Unit was operated with an input power level lower than safe operating range for an extended period of time.</td> <td data-bbox="1182 1127 1448 1346"> <ul style="list-style-type: none"> • Check data in unit. Totalizer may have inaccuracies • Investigate brownout cause. </td> </tr> </tbody> </table>	Error/Warning Message	Cause	Remedy	TOTALIZER ROLLOVER	Displayed when totalizer rolls over	<ul style="list-style-type: none"> • Acknowledge Rollover • Remedy not required 	RATE OVERFLOW ERROR	Pulse counter overflowed. The totalizer may have lost counts.	<ul style="list-style-type: none"> • Report error to factory • Check application conditions • Check wiring 	PULSE OUT OVERFLOW	Calculated pulse frequency too large: <ul style="list-style-type: none"> • Pulse width setting too long • Larger pulse scaler needed 	<ul style="list-style-type: none"> • Adjust pulse value • Adjust pulse width • Check process conditions 	FLOW RATE ALARM LOW FLOW RATE ALARM HIGH	Limit value exceeded.	<ul style="list-style-type: none"> • Check application if necessary • Check limit value • Adjust the limit value if required 	BATCH OVERRUN ALARM	Batch size exceeded by more than set limit.	<ul style="list-style-type: none"> • Check valves in system for proper operation and/or leaks • Check limit value • Adjust the limit value if required 	MODEM NOT PRESENT	The setup expects modem usage and a modem is not responding.	<ul style="list-style-type: none"> • Check setup for proper baud rate, parity, etc. • Check modem connection and cycle power to ST1LE • Replace modem 	SOFTWARE ERROR RESET	Software error	<ul style="list-style-type: none"> • Report error to factory 	EXTENDED PFI LOCKUP	Unit was operated with an input power level lower than safe operating range for an extended period of time.	<ul style="list-style-type: none"> • Check data in unit. Totalizer may have inaccuracies • Investigate brownout cause.
Error/Warning Message	Cause	Remedy																										
TOTALIZER ROLLOVER	Displayed when totalizer rolls over	<ul style="list-style-type: none"> • Acknowledge Rollover • Remedy not required 																										
RATE OVERFLOW ERROR	Pulse counter overflowed. The totalizer may have lost counts.	<ul style="list-style-type: none"> • Report error to factory • Check application conditions • Check wiring 																										
PULSE OUT OVERFLOW	Calculated pulse frequency too large: <ul style="list-style-type: none"> • Pulse width setting too long • Larger pulse scaler needed 	<ul style="list-style-type: none"> • Adjust pulse value • Adjust pulse width • Check process conditions 																										
FLOW RATE ALARM LOW FLOW RATE ALARM HIGH	Limit value exceeded.	<ul style="list-style-type: none"> • Check application if necessary • Check limit value • Adjust the limit value if required 																										
BATCH OVERRUN ALARM	Batch size exceeded by more than set limit.	<ul style="list-style-type: none"> • Check valves in system for proper operation and/or leaks • Check limit value • Adjust the limit value if required 																										
MODEM NOT PRESENT	The setup expects modem usage and a modem is not responding.	<ul style="list-style-type: none"> • Check setup for proper baud rate, parity, etc. • Check modem connection and cycle power to ST1LE • Replace modem 																										
SOFTWARE ERROR RESET	Software error	<ul style="list-style-type: none"> • Report error to factory 																										
EXTENDED PFI LOCKUP	Unit was operated with an input power level lower than safe operating range for an extended period of time.	<ul style="list-style-type: none"> • Check data in unit. Totalizer may have inaccuracies • Investigate brownout cause. 																										
<p>11.3.2 Self Test Alarms</p>	<table border="1"> <thead> <tr> <th data-bbox="493 1411 829 1457">Error/Warning Message</th> <th data-bbox="829 1411 1182 1457">Cause</th> <th data-bbox="1182 1411 1448 1457">Remedy</th> </tr> </thead> <tbody> <tr> <td data-bbox="493 1457 829 1591">BATTERY LOW WARNING</td> <td data-bbox="829 1457 1182 1591">Battery voltage too low</td> <td data-bbox="1182 1457 1448 1591"> <ul style="list-style-type: none"> • Replace Battery • Consult Factory for service information </td> </tr> <tr> <td data-bbox="493 1591 829 1774">TIME CLOCK ERROR</td> <td data-bbox="829 1591 1182 1774">The correct time/date is no longer shown</td> <td data-bbox="1182 1591 1448 1774"> <ul style="list-style-type: none"> • Re-enter time and date. • If error occurs again contact factory </td> </tr> <tr> <td data-bbox="493 1774 829 1864">CAL CHECKSUM ERROR</td> <td data-bbox="829 1774 1182 1864">Calibration constants have been corrupted</td> <td data-bbox="1182 1774 1448 1864"> <ul style="list-style-type: none"> • Report error to factory </td> </tr> <tr> <td data-bbox="493 1864 829 1955">SETUP CHECKSUM ERROR</td> <td data-bbox="829 1864 1182 1955">The units setup has been corrupted</td> <td data-bbox="1182 1864 1448 1955"> <ul style="list-style-type: none"> • Report error to factory </td> </tr> </tbody> </table>	Error/Warning Message	Cause	Remedy	BATTERY LOW WARNING	Battery voltage too low	<ul style="list-style-type: none"> • Replace Battery • Consult Factory for service information 	TIME CLOCK ERROR	The correct time/date is no longer shown	<ul style="list-style-type: none"> • Re-enter time and date. • If error occurs again contact factory 	CAL CHECKSUM ERROR	Calibration constants have been corrupted	<ul style="list-style-type: none"> • Report error to factory 	SETUP CHECKSUM ERROR	The units setup has been corrupted	<ul style="list-style-type: none"> • Report error to factory 												
Error/Warning Message	Cause	Remedy																										
BATTERY LOW WARNING	Battery voltage too low	<ul style="list-style-type: none"> • Replace Battery • Consult Factory for service information 																										
TIME CLOCK ERROR	The correct time/date is no longer shown	<ul style="list-style-type: none"> • Re-enter time and date. • If error occurs again contact factory 																										
CAL CHECKSUM ERROR	Calibration constants have been corrupted	<ul style="list-style-type: none"> • Report error to factory 																										
SETUP CHECKSUM ERROR	The units setup has been corrupted	<ul style="list-style-type: none"> • Report error to factory 																										

12.1 SETUP MENUS

SETUP MENUS

START HERE

SELECT EZ SETUP

INSTRUMENT TYPE

INSTRUMENT TYPE	SELECT PRESET TYPE	BATCH COUNT MODE	MAX. BATCH PRESET	BATCH OVERRIDE COMP.	AUTO BATCH RESTART	TIME DELAY	FLOW SIGNAL TIMEOUT	MAX. DRAIN TIME	SLOW START QUANTITY
-----------------	--------------------	------------------	-------------------	----------------------	--------------------	------------	---------------------	-----------------	---------------------

SETUP INDICATORS

SETUP INDICATORS	TOTAL DESCRIP. TONS	VOLUME UNITS	TOTAL DECIMAL PLACES	RATE TIME BASE	RATE DESCRIP. TOR	RATE DECIMAL PLACES	RATE AVERAGE FILTER	QUICK UPDATE %
------------------	---------------------	--------------	----------------------	----------------	-------------------	---------------------	---------------------	----------------

SETUP FLOW INPUT

EXCITATION VOLTAGE	PULSE INPUT TYPE	PULSE TRIGGER TYPE	LOW PASS FILTER	INPUT TERMINATION	MAX WINDOW	K-FACTOR TYPE	AVERAGE K-A FACTOR	AVERAGE KB-FACTOR	CHANGE TABLE A	CHANGE TABLE B	LOW FLOW RATE ALARM	HIGH FLOW RATE ALARM
--------------------	------------------	--------------------	-----------------	-------------------	------------	---------------	--------------------	-------------------	----------------	----------------	---------------------	----------------------

SETUP PULSE OUTPUT

PULSE OUTPUT USAGE	PULSE WIDTH	PULSE VALUE
--------------------	-------------	-------------

SETUP ANALOG OUTPUT

ANALOG OUTPUT USAGE	ANALOG OUTPUT RANGE	ANALOG OUT LOW SCALE	ANALOG OUT FULL SCALE	ANALOG OUT DAMPING
---------------------	---------------------	----------------------	-----------------------	--------------------

SETUP RELAYS

SETUP RELAYS 1, 2, 3, 4	RELAY USAGE	RELAY DELAY	RELAY DURATION	RELAY MODE	RELAY SETPOINT	RELAY HYSTERESIS
-------------------------	-------------	-------------	----------------	------------	----------------	------------------

SETUP CONTROL INPUTS

SETUP CONTROL INPUTS 1, 2, 3	CONTROL INPUT 1 USAGE	CONTROL INPUT 2 USAGE	CONTROL INPUT 3 USAGE
------------------------------	-----------------------	-----------------------	-----------------------

SETUP REAL TIME CLOCK

SETUP REAL TIME CLOCK	CLOCK TYPE	SELECT CLOCK AM/PM	TIME OF DAY	ENTER DATE
-----------------------	------------	--------------------	-------------	------------

SERIAL USAGE

SERIAL HARDWARE	DEVICE ID	BAUD RATE	PARITY	HANDSHAKE	DEVICE LINE FEED	MODEM CONTROL	MODEM AUTO ANSWER	CALL OUT NO	CALL OUT TIME	CALL ON ERROR ALARM	NUMBER OF REDIALS	HANG-UP F 2MIN. INACTIVE
-----------------	-----------	-----------	--------	-----------	------------------	---------------	-------------------	-------------	---------------	---------------------	-------------------	--------------------------

SETUP DATALOG/PRINT

SETUP DATALOG/PRINT	OUTPUT FORMAT	PAGE LENGTH	TOP MARGIN	DATALOG ONLY	PRINT TIME	PRINT INTERVAL	ENABLE PRINT KEY	PRINT END OF BATCH	CLEAR TOTAL IF PRINT	SELECT PRINT LIST ITEMS
---------------------	---------------	-------------	------------	--------------	------------	----------------	------------------	--------------------	----------------------	-------------------------

ADMINISTRATIVE SETUP

OPERATOR PASSWORD	SUPERVISOR PASSWORD	SOFTWARE VERSION	PRODUCT ORDER CODE	UNIT SERIAL NUMBER	SENSOR SERIAL NUMBER
-------------------	---------------------	------------------	--------------------	--------------------	----------------------

SETUP NETWORK CARD

SELECT NET-WORK PROTOCOL	NETWORK DEVICE ID	BAUD RATE	PARITY
--------------------------	-------------------	-----------	--------

These functions will only appear with appropriate settings in other functions.

13 WARRANTY AND RETURN STATEMENT

These products are sold by The Anderson Instrument Company (Anderson) under the warranties set forth in the following paragraphs. Such warranties are extended only with respect to a purchase of these products, as new merchandise, directly from Anderson or from an Anderson distributor, representative or reseller, and are extended only to the first buyer thereof who purchases them other than for the purpose of resale.

WARRANTY

These products are warranted to be free from functional defects in materials and workmanship at the time the products leave the Anderson factory and to conform at that time to the specifications set forth in the relevant Anderson instruction manual or manuals, sheet or sheets, for such products for a period of two years.

THERE ARE NO EXPRESSED OR IMPLIED WARRANTIES WHICH EXTEND BEYOND THE WARRANTIES HEREIN AND ABOVE SET FORTH. ANDERSON MAKES NO WARRANTY OF MERCHANTABILITY OR FITNESS FOR A PARTICULAR PURPOSE WITH RESPECT TO THE PRODUCTS.

LIMITATIONS

Anderson shall not be liable for any incidental damages, consequential damages, special damages, or any other damages, costs or expenses excepting only the cost or expense of repair or replacement as described above.

Products must be installed and maintained in accordance with Anderson instructions. Users are responsible for the suitability of the products to their application. There is no warranty against damage resulting from corrosion, misapplication, improper specifications or other operating condition beyond our control. Claims against carriers for damage in transit must be filed by the buyer.

This warranty is void if the purchaser uses non-factory approved replacement parts and supplies or if the purchaser attempts to repair the product themselves or through a third party without Anderson authorization.

RETURNS

Anderson's sole and exclusive obligation and buyer's sole and exclusive remedy under the above warranty is limited to repairing or replacing (at Anderson's option), free of charge, the products which are reported in writing to Anderson at its main office indicated below.

Anderson is to be advised of return requests during normal business hours and such returns are to include a statement of the observed deficiency. The buyer shall pre-pay shipping charges for products returned and Anderson or its representative shall pay for the return of the products to the buyer.

Approved returns should be sent to:

ANDERSON INSTRUMENT COMPANY INC.
ATT: REPAIR DEPARTMENT
156 AURIESVILLE ROAD
FULTONVILLE, NY 12072 USA



ANDERSON-NEGELE

ANDERSON INSTRUMENT CO., INC • 156 AURIESVILLE RD. • FULTONVILLE, NY 12072 • USA • 800-833-0081 • FAX 518-922-8997
ANDERSON INSTRUMENT CO. LP • 400 BRITANNIA RD. EAST, UNIT 1 • MISSISSAUGA, ONTARIO L4Z 1X9 • CANADA • 905-603-4358 • FAX 905-568-1652
NEGELE MESSTECHNIK GmbH (A Division of Anderson) • RAIFFEISENWEIG 7 • D-87743 EGG A. D. GÜNZ • GERMANY • +49 (0) 8333/9204-0 • FAX +49 (0) 8333/9204-49

www.anderson-negele.com