



Instruction Manual
Universal Lobe Series
Rotary Positive Displacement Pump



Read and understand this manual prior to operating or servicing this product.





611 Sugar Creek Road
Delavan, WI 53115 USA

Tel: (800) 252-5200 or (262) 728-1900

Fax: (800) 252-5012 or (262) 728-4904

E-mail: wcb@spx.com

Web site: www.spxpe.com

Information contained in this manual is subject to change without notice and does not represent a commitment on the part Information contained in this manual is subject to change without notice and does not represent a commitment on the part of SPX Corporation. No part of this manual may be reproduced or transmitted in any form or by any means, electronic or mechanical, including photocopying and recording, for any purpose, without the express written permission of SPX Corporation.

Copyright © 2009 SPX Corporation. All Rights Reserved.

Gore-Tex is a registered trademark of
W.L. Gore & Associates, Inc.
Kalrez is a registered trademark of DuPont Dow Elastomers.
Chemraz is a registered trademark of Green, Tweed & Co.

Issued Date: **November 2009**

Publication: **95-03092**

Waukesha Cherry-Burrell Warranty	5
Shipping Damage or Loss	5
Warranty Claim	5
Safety	6
Replacement Labels	7
Application Instructions	7
Care of Stainless Steel	8
Stainless Steel Corrosion	8
Alloy 88	8
Elastomer Seal Replacement Following Passivation	8
Introduction	9
Pump Receiving	9
Pump Characteristics	9
Equipment Serial Number	9
Pump Shaft Location	9
Installation	10
Install Pump and Drive Unit	10
Install Connections and Piping	11
Install Check Valves	12
Install Isolation Valves	12
Install Relief Valves	12
Inlet Side Strainers and Traps	13
Install Pressure Gauges	13
Seal Flush Connections	13
CIP (Clean-In-Place) Features	14
Check Coupling Alignment	15
Check Angular Alignment	15
Check Parallel Alignment	15
Check Belt and Chain Drive Alignment	16
Check Pump Rotation	16
Operation	17
Pre-Startup Checklist	17
Startup Procedure	17
Shutdown Procedure	17
Emergency Shutdown Procedure	17
Maintenance	18
Important Safety Information	18
Lubrication	18
Maintenance Inspections	19
Maintenance Inspection Chart	21
Annual Maintenance	22
Cleaning	22
Fluid Head Disassembly	23
Gear Case Disassembly	25
Shaft Assembly	28
Gear Case Assembly	30
Fluid Head Assembly	41
Reference Tables	44
Standard WCB O-Ring Selections, Descriptions and Color Codes	45
Parts Lists	46
018-UL PD Pumps	46
030-UL, 034-UL, 050-UL, 054-UL PD Pumps	50
060-UL, 130-UL, 134-UL PD Pumps	56
220-UL PD Pumps	62
320-UL PD Pumps	66

320-UL PD Pumps	69
Universal UL PD Pump Seals	70
Vented Cover Parts - Model 018, 030, 034, 050, 054, 060, 130, 134 UL	71
Vented Cover Parts - Model 220 UL	72
UL Pump Dimensions	73
Universal UL Pump Dimensions and Model Weights	73
Rectangular Flange Universal UL Pump Dimensions and Model Weights	74
Troubleshooting	75

Waukesha Cherry-Burrell Warranty

Seller warrants its products to be free from defect in materials and workmanship for a period of one (1) year from the date of shipment. This warranty shall not apply to products which require repair or replacement due to normal wear and tear or to products which are subjected to accident, misuse or improper maintenance. This warranty extends only to the original Buyer. Products manufactured by others but furnished by Seller are exempted from this warranty and are limited to the original manufacturer's warranty.

Seller's sole obligation under this warranty shall be to repair or replace any products that Seller determines, in its discretion, to be defective. Seller reserves the right either to inspect the products in the field or to request their prepaid return to Seller. Seller shall not be responsible for any transportation charges, duty, taxes, freight, labor or other costs. The cost of removing and/or installing products which have been repaired or replaced shall be at Buyer's expense.

Seller expressly disclaims all other warranties, express or implied, including without limitation any warranty of merchantability of fitness for a particular purpose. The foregoing sets forth Seller's entire and exclusive liability, and Buyer's exclusive and sole remedy, for any claim of damages in connection with the sale of products. In no event shall Seller be liable for any special consequential incidental or indirect damages (including without limitation attorney's fees and expenses), nor shall Seller be liable for any loss of profit or material arising out of or relating to the sale or operation of the products based on contract, tort (including negligence), strict liability or otherwise.

Shipping Damage or Loss

If equipment is damaged or lost in transit, file a claim at once with the delivering carrier. The carrier has signed the Bill of Lading acknowledging that the shipment has been received from WCB in good condition. WCB is not responsible for the collection of claims or replacement of materials due to transit shortages or damages.

Warranty Claim

Warranty claims must have a **Returned Goods Authorization (RGA)** from the Seller before returns will be accepted.

Claims for shortages or other errors, exclusive of transit shortages or damages, must be made in writing to Seller within ten (10) days after delivery. Failure to give such notice shall constitute acceptance and waiver of all such claims by Buyer.

Safety

READ AND UNDERSTAND THIS MANUAL PRIOR TO INSTALLING, OPERATING OR SERVICING THIS EQUIPMENT

Waukesha Cherry-Burrell recommends users of our equipment and designs follow the latest Industrial Safety Standards. At a minimum, these should include the industrial safety requirements established by:

1. Occupational Safety and Health Administration (OSHA), Title 29 of the CFR
Section 1910.212- General Requirements for all Machines
2. National Fire Protection Association, ANSI/NFPA 79
ANSI/NFPA 79- Electrical Standards for Industrial Machinery
3. National Electrical Code, ANSI/NFPA 70
ANSI/NFPA 70- National Electrical Code
ANSI/NFPA 70E- Electrical Safety Requirement for Employee Workplaces
4. American National Standards Institute, Section B11

Attention: Servicing energized industrial equipment can be hazardous. Severe injury or death can result from electrical shock, burn, or unintended actuation of controlled equipment. Recommended practice is to disconnect and lockout industrial equipment from power sources, and release stored energy, if present. Refer to the National Fire Protection Association Standard No. NFPA70E, Part II and (as applicable) OSHA rules for Control of Hazardous Energy Sources (Lockout-Tagout) and OSHA Electrical Safety Related Work Practices, including procedural requirements for:

- Lockout-tagout
- Personnel qualifications and training requirements
- When it is not feasible to de-energize and lockout-tagout electrical circuits and equipment before working on or near exposed circuit parts

Locking and Interlocking Devices: These devices should be checked for proper working condition and capability of performing their intended functions. Make replacements only with the original manufacturer's renewal parts or kits. Adjust or repair in accordance with the manufacturer's instructions.

Periodic Inspection: Industrial equipment should be inspected periodically. Inspection intervals should be based on environmental and operating conditions and adjusted as indicated by experience. At a minimum, an initial inspection within 3 to 4 months after installation is recommended. Inspection of the electrical control systems should meet the recommendations as specified in the National Electrical Manufacturers Association (NEMA) Standard No. ICS 1.3, Preventative Maintenance of Industrial Control and Systems Equipment, for the general guidelines for setting-up a periodic maintenance program.

Replacement Equipment: Use only replacement parts and devices recommended by the manufacturer to maintain the integrity of the equipment. Make sure the parts are properly matched to the equipment series, model, serial number, and revision level of the equipment.

Warnings and cautions are provided in this manual to help avoid serious injury and/or possible damage to equipment.



DANGER: marked with a stop sign.
Immediate hazards which WILL result in severe personal injury or death.



WARNING: marked with a warning triangle.
Hazards or unsafe practices which COULD result in severe personal injury or death.



CAUTION: marked with a warning triangle.
Hazards or unsafe practices which COULD result in minor personal injury or product or property damage.

Replacement Labels

WARNING: The following labels are installed on your equipment. If these labels are removed or become unreadable contact Waukesha Cherry-Burrell customer service at 1-800-252-5200 or 262-728-1900, or refer to "Parts Lists" on page 46 for replacement part numbers.

Application Instructions

Apply to clean, dry surface. Remove backing from label, place in proper position, protect with cover sheet and burnish. (A soft rubber roller also may be used to press label into place.) Apply all labels to be readable from front of pump.

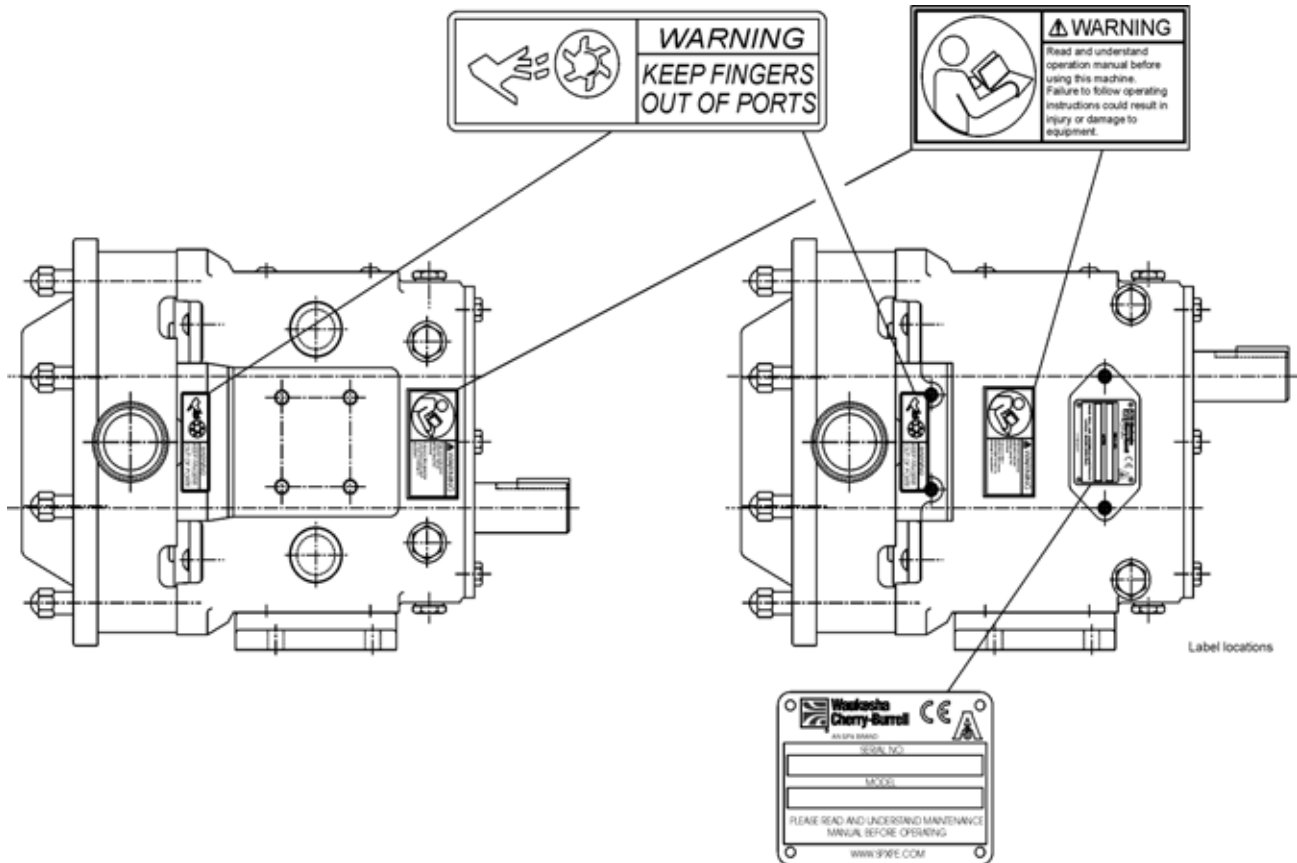

IMPORTANT

1. Pump and Drive are factory aligned.
2. Recheck alignment after installation and before start-up.
3. Recheck alignment periodically, to maximize service life.

PD100-238a 33-95

IMPORTANT

To avoid damage to the shaft seals and/or pump parts:

DO NOT START this pump unless Seal Flush has been installed and is turned ON.

PD100-238a

Care of Stainless Steel

Stainless Steel Corrosion

Corrosion resistance is greatest when a layer of oxide film is formed on the surface of stainless steel. If film is disturbed or destroyed, stainless steel becomes much less resistant to corrosion and may rust, pit or crack.

Corrosion pitting, rusting and stress cracks may occur due to chemical attack. Use only cleaning chemicals specified by a reputable chemical manufacturer for use with 300 series stainless steel. Do not use excessive concentrations, temperatures or exposure times. Avoid contact with highly corrosive acids such as hydrofluoric, hydrochloric or sulfuric. Also avoid prolonged contact with chloride-containing chemicals, especially in presence of acid. If chlorine-based sanitizers are used, such as sodium hypochlorite (bleach), do not exceed concentrations of 150 ppm available chlorine, do not exceed contact time of 20 minutes, and do not exceed temperatures of 104°F (40°C).

Corrosion discoloration, deposits or pitting may occur under product deposits or under gaskets. Keep surfaces clean, including those under gaskets or in grooves or tight corners. Clean immediately after use. Do not allow equipment to set idle, exposed to air with accumulated foreign material on the surface.

Corrosion pitting may occur when stray electrical currents come in contact with moist stainless steel. Ensure all electrical devices connected to the equipment are correctly grounded.

Alloy 88

Waukesha Alloy 88 is the standard rotor material for Universal I, Universal II, Universal Lobe, Universal 420/520 and 5000 Series Rotary PD pumps. This alloy was developed specifically for corrosion resistance and close operating clearance requirements of high performance rotary positive displacement pumps. Alloy 88 is a nickel-based, corrosion-resistant, non-galling or seizing material. The ASTM designation is A494 Grade CY5SnBiM (UNS N26055), and the material is listed in the 3-A Sanitary Standards as acceptable for product contact surfaces.

The above properties make Alloy 88 the ideal material for Waukesha stainless steel PD pumps. The non-galling rotors permit close operating clearances in the liquid end. This provides low slip and minimum shear damage. The rotors will not gall or seize if they come in contact with the body or cover during operation.

The corrosion resistance of Alloy 88 is approximately equal to AISI 300 Series Stainless Steel. However, Alloy 88 has limited resistance to certain aggressive chemicals that may be commonly used in contact with AISI 300 Series Stainless Steel.

Do not use Alloy 88 in contact with nitric acid. Nitric acid is commonly used to passivate new installations of stainless steel equipment. Do not allow nitric acid based passivation chemicals to contact Alloy 88 rotors. Remove the rotors during passivation and use a separate pump to circulate the passivation chemicals. Also, if nitric acid-based CIP cleaning chemicals are used, remove the rotors prior to CIP cleaning and clean them separately by hand in a mild detergent.

If you have questions regarding other aggressive chemicals, please contact Waukesha Cherry-Burrell Application Engineering for assistance.

Elastomer Seal Replacement Following Passivation

Passivation chemicals can damage product contact areas of WCB equipment. Elastomers (rubber components) are most likely to be affected. Always inspect all elastomer seals after passivation is completed. Replace any seals showing signs of chemical attack. Indications may include swelling, cracks, loss of elasticity or any other noticeable changes when compared with new components.

Introduction

Pump Receiving



DANGER: The pump contains internal moving parts. DO NOT put hands or fingers into the pump body ports or drive area at any time during operation. To avoid serious injury, DO NOT install, clean, service, or repair the pump unless all power is off and locked out.

All ports are covered at the factory to keep out foreign objects during transit. If covers are missing or damaged, remove the pump cover and thoroughly inspect the fluid head. Be sure the pumping head is clean and free of foreign material before rotating the shaft.

Each Waukesha Cherry-Burrell pump is shipped completely assembled, lubricated and ready for use. Review “Operation” on page 17 before operating the pump.

Pump Characteristics

Waukesha Cherry-Burrell Universal Lobe pumps are positive-displacement, low-slip, stainless steel pumps designed with larger diameter shafts for greater strength and stiffness, mounted on a heavy-duty cast iron bearing frame (stainless steel option available) with double-tapered roller bearings.

- Designed for continuous operation.
- Rotor hubs are sealed from the product zone; rotors are locked with belleville-style washers and torqued nuts that can rotate securely in either direction (bi-directional).
- Non-galling “88” alloy rotors are standard; 316 material rotors are optional.
- Seal flush is standard. Seal areas are interconnected to improve circulation and draining of the seal flush fluid.
- Single mechanical seals are standard. Bodies are pre-drilled with flush ports if double seals are required.
- Free-draining pump body and cover when mounted on its side.
- CIP capability is standard.

Equipment Serial Number

All Waukesha Cherry-Burrell pumps are identified by a serial number on the gear case nameplate, which is stamped on the pump body and cover.



CAUTION: The gear case, body, and cover must be kept together as a unit due to backface, rotor and cover clearances. Failure to do so will damage the pump.

Pump Shaft Location

There are two pump drive shaft locations.

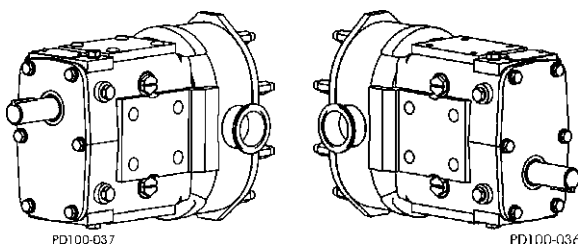

Figure 1 - Upper and Lower Shaft Mount

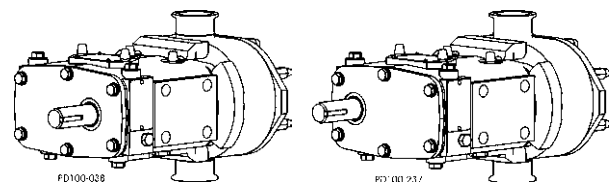

Figure 2 - Sidemount Left Hand and Right Hand (as viewed from pump cover)

Installation

Install the pump and piping system in accordance with local codes and restrictions. Practices described in this manual are recommended for optimum performance.

All system equipment, such as motors, sheaves, drive couplings, speed reducers, etc., must be properly sized to ensure satisfactory operation of your Waukesha Cherry-Burrell pump within its limits.

CAUTION: These pumps are positive displacement, low-slip design and will be severely damaged if operated with closed valves in the discharge or inlet lines. The pump warranty is not valid for damages caused by a hydraulic overload from operation or start-up with a closed valve in the system.

WARNING: Full guards must be installed to isolate operators and maintenance personnel from the rotating components. Guards are provided with Waukesha Cherry-Burrell pumps as part of a complete pump and drive package.

Install Pump and Drive Unit

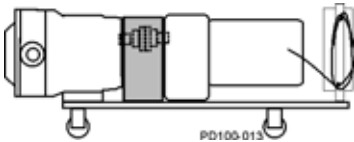

Figure 3 - Portable Base

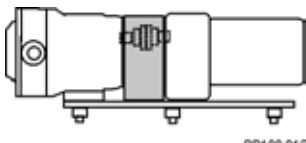

Figure 4 - Adjustable Leg Base

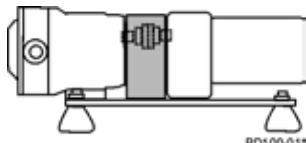

Figure 5 - Leveling and/or Vibration Isolation Pads

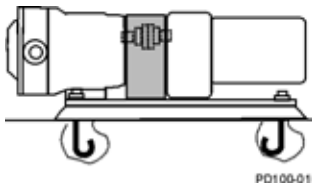

Figure 6 - Permanent Installation on Foundation

In a typical installation configuration, the pump and drive unit are mounted on a common base plate. The unit can be installed in any of the arrangements shown in Figure 3 through Figure 6 (the shaded area indicates the guard location).

NOTE: When installing unit as shown in Figure 6, level the unit before installing the bolts.

Install Connections and Piping

Fittings

Waukesha Cherry-Burrell produces a wide variety of fittings made to meet your needs. Contact Waukesha Cherry-Burrell Customer Service at 1-800-252-5200 or 262-728-1900 for information on fittings.

Piping Support

Support all piping to the pump independently with hangers or pedestals to minimize the forces exerted on the pump. Such forces can cause misalignment of pump parts and lead to excessive wear of rotors, bearings and shafts.

Figure 7 shows typical supporting methods used to independently support each pipe, reducing the weight effect of piping and fluid on the pump.

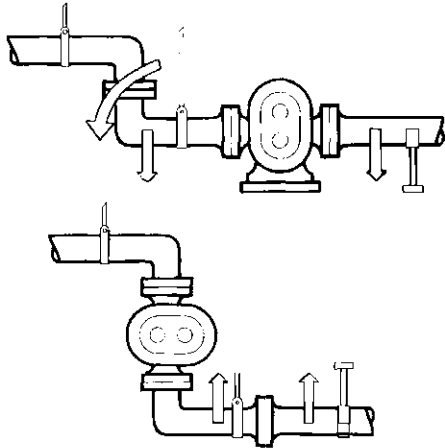

Figure 7 - Piping Support

Expansion Joints

Thermal expansion of piping can cause tremendous forces. Use thermal expansion joints to minimize these forces on the pump.

Flexible joints can be used to limit transmission of mechanical vibration. Ensure that the free ends of any flexible connections in the system are anchored.

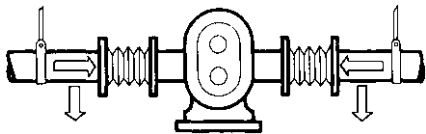

Figure 8 - Flexible Connections and Supports

Inlet Piping

Install the pump below the supply liquid level to reduce air in the system by flooded suction (Figure 9).

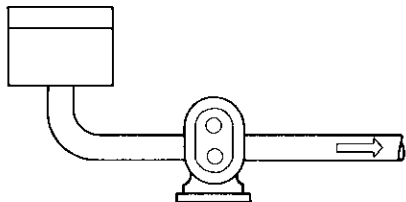

Figure 9 - Pump Below Supply

If the pump is installed above the supply liquid level, the piping on the inlet side must slope up toward the pump, preventing air pockets in the pipes (Figure 10).

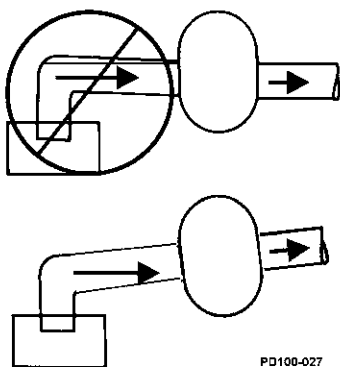
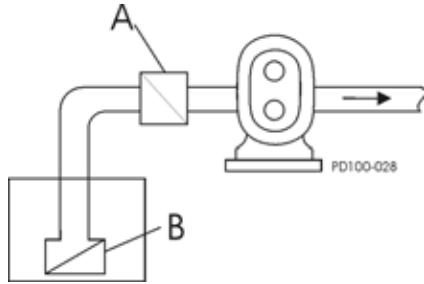

Figure 10 - Correct Piping to Prevent Inlet Air Pockets

PD100-027

Install Check Valves



- A. Inlet Check Valve
- B. Foot Check Valve

Figure 11 - Inlet/Foot Check Valve

Inlet Side on Lift Applications

Use check valves to keep the inlet line full, particularly with low-viscosity fluids (Figure 11).

Discharge Side

For systems with liquid under a vacuum, install a check valve on the discharge side of the pump. A check valve prevents backflow (air or fluid) to aid in initial start-up by minimizing the required differential pressure supplied by the pump to start the flow (Figure 12).

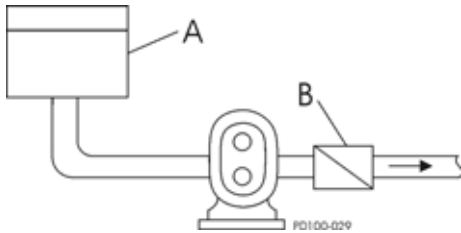

- A. Closed Tank - produces vacuum on liquid (Low Absolute Pressure)
- B. Check Valve (outlet)

Figure 12 - Discharge Check Valve

Install Isolation Valves



Figure 13 - Isolation Valves

Isolation valves permit pump maintenance and safe pump removal without draining the system (Figure 13, item A).

Install Relief Valves

Install relief valves to protect the pump and piping system against excessive pressure. WCB recommends installing an external relief valve, designed to bypass fluid from the pump outlet to the inlet side of system (Figure 14, item A).

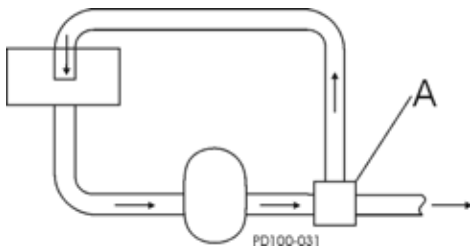
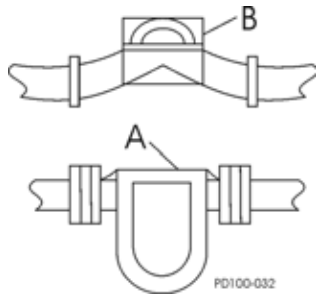

Figure 14 - Relief Valves

NOTE: Integral relief valves are available, but are not recommended on applications with viscosities over 500 cps or where the discharge must be closed for more than a few minutes. Prolonged operation of the pump with closed discharge will cause heating of fluid circulating through the relief valve. If this is the case, install an external relief valve to discharge externally through the piping connected to the fluid source, or into inlet piping near the source.

Inlet Side Strainers and Traps



A. Strainer B. Magnetic Trap

Figure 15 - In-line Strainers and Traps

Inlet side strainers and traps (Figure 15, items A and B) can be used to prevent foreign matter from damaging the pump. Make the selection carefully to prevent cavitation caused by the restriction of the inlet. If the inlet strainers are used, they must be serviced regularly to prevent clogging and flow stoppage.

Install Pressure Gauges

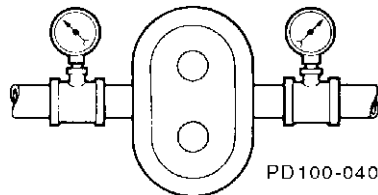

Figure 16 - Pressure and Vacuum Gauges

Pressure and vacuum gauges provide valuable information about pump operation (Figure 16). Wherever possible, install gauges to help provide information on the following:

- Normal or abnormal pressures
- Indication of flow
- Changes in pump condition
- Changes in system conditions
- Changes in fluid viscosity

Seal Flush Connections

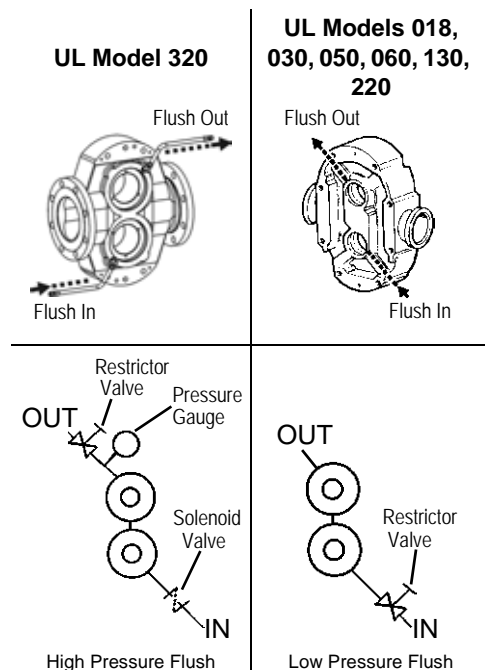

Figure 17 - Flush Piping Setup

Pumps with double seals require flushing. The flush media (typically water) must be connected and flowing whenever pump is operated.



WARNING: Operating the pump without flush will damage the seal and pump parts due to excess heat from dry running.

Pump bodies have two 1/8-inch female pipe thread flush connections located near bottom and top of body.

1. Connect the flush inlet to the lower connection, and the outlet to the upper connection, to flood the flush area completely.
2. Connect the flush outlet for unrestricted flow to the drain.

NOTE: If steam is used as flush media, connect the inlet at the upper connection and the outlet at the lower connection, to ensure condensation removal.

3. Use cool, filtered flush media to obtain maximum service life of the seal components. If the pumped product is sticky or solidifies at room temperature, use warm or hot flush media.
4. Install a pressure reducing valve and flow control valve (needle valve) on the flush supply line. Set the supply pressure at a maximum of 30 psi (2 bar) and adjust the flow rate to approximately 1/4 gpm (more for high-temperature applications).

5. Also install a solenoid valve in the flush supply and wire it in series with the motor starter to provide an automatic start/stop of the flush media flow before the motor turns on and after the motor turns off.

NOTE: *If the pumped product contains abrasive solids or hardens on the seal faces, an alternate high pressure barrier flush arrangement may be used. A very small amount of flush liquid enters the pumped liquid, therefore the flush media must be compatible with the product. Contact WCB Application Engineering for assistance.*

CIP (Clean-In-Place) Features

WCB UL pumps are designed to provide CIP solutions complete access to all product contact surfaces. The flat body profile allows complete draining of the side-mounted pump, and provides the CIP solution access to the entire cover o-ring groove.

Use the following guidelines when designing and installing the CIP system to ensure successful cleaning:

- Ensure that the velocity rate of CIP solutions is adequate to clean the entire circuit. For most applications, a velocity of 5 ft/sec is sufficient. For the CIP solution to achieve the proper velocity, the pump drive must have enough speed range and horsepower. The required inlet pressure also must be satisfied. If the pump does not supply enough CIP solution velocity, a separate CIP supply pump with an installed bypass may be used. To determine the appropriate bypass arrangement, contact WCB Application Engineering.
- Ensure that a differential pressure is created across the pump. Differential pressure will push CIP solutions through close-clearance areas of the pump, resulting in better cleaning action. The high pressure side may be either the inlet or outlet side. 30 psi (2 bar) differential pressure is adequate for most applications.
- The pump must be operated during CIP to increase turbulence and cleaning action within the pump. If complete draining is required, the pump must be in the side mount position.

Check Coupling Alignment



Figure 18 - Lovejoy Coupling



Figure 19 - T.B. Woods® Coupling

Pumps and drives ordered from the factory and mounted on a common base plate are aligned before shipment. Alignment **must** be re-checked after the complete unit has been installed and piping completed. Periodic re-checking is advisable during the pump service life.

- WCB recommends using a flexible coupling to connect the drive to the pump. Several different types are available, including couplings with slip or overload provisions. Waukesha Cherry-Burrell provides Lovejoy (Figure 18) or T.B. Woods® (Figure 19) couplings unless otherwise specified when ordering. Flexible couplings can be used to compensate for end play and small differences in alignment.

- Align the pump and drive shaft as closely as possible:

Pump and Drive are factory aligned.

Re-check alignment after installation and before start-up.

Re-check alignment periodically, to maximize service life.

Check Angular Alignment

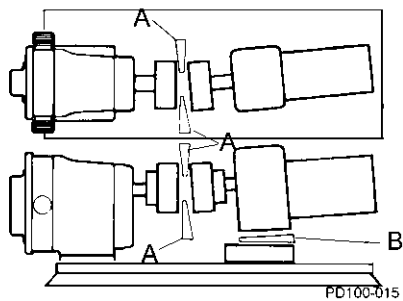

Figure 20 - Check Angular Alignment

1. Using feeler gauges or taper gauges (Figure 20, items A and B), check the alignment at four points every 90 degrees around the coupling; **adjust to equal dimension at all points.**
2. Set the space between the coupling halves to the manufacturer's recommended distance.
3. Install shims to bring the system into alignment.

Check Parallel Alignment

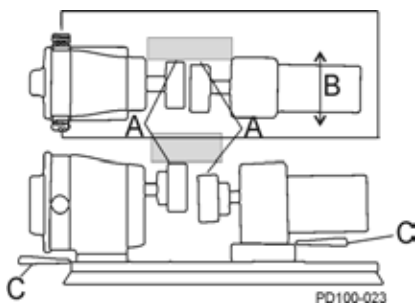

Figure 21 - Check Parallel Alignment

1. Check both the horizontal and vertical alignment of the pump and drive using a straight edge.
2. Using a feeler gauge at location "A" in Figure 21, determine the direction and amount of movement needed (Figure 21, item B).
3. If necessary, shim at location "C" and/or move the drive as needed.

Check Belt and Chain Drive Alignment

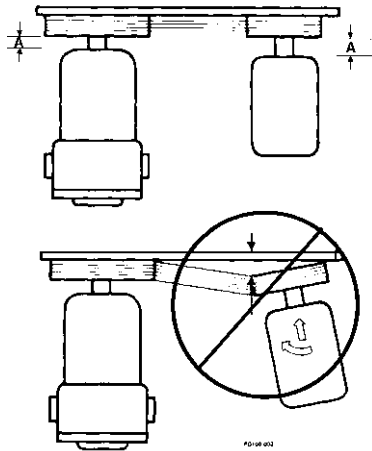

Figure 22 - Aligning Belt and Chain Drives

Use a straight edge to visually check the belt or chain alignment. Keep the shaft distance to a minimum (Figure 22, item A).

After the piping is complete and before the belts are installed, manually turn the pump shaft to ensure that it turns freely.

Check Pump Rotation

Check the direction of the drive rotation to determine the rotation direction of the pump (Figure 23). After the correct drive rotation is verified, connect the coupling and assemble the pump and coupling guards.

NOTE: The pump covers in the following figures have been removed to view rotor rotation. Never operate the pump with the covers removed.

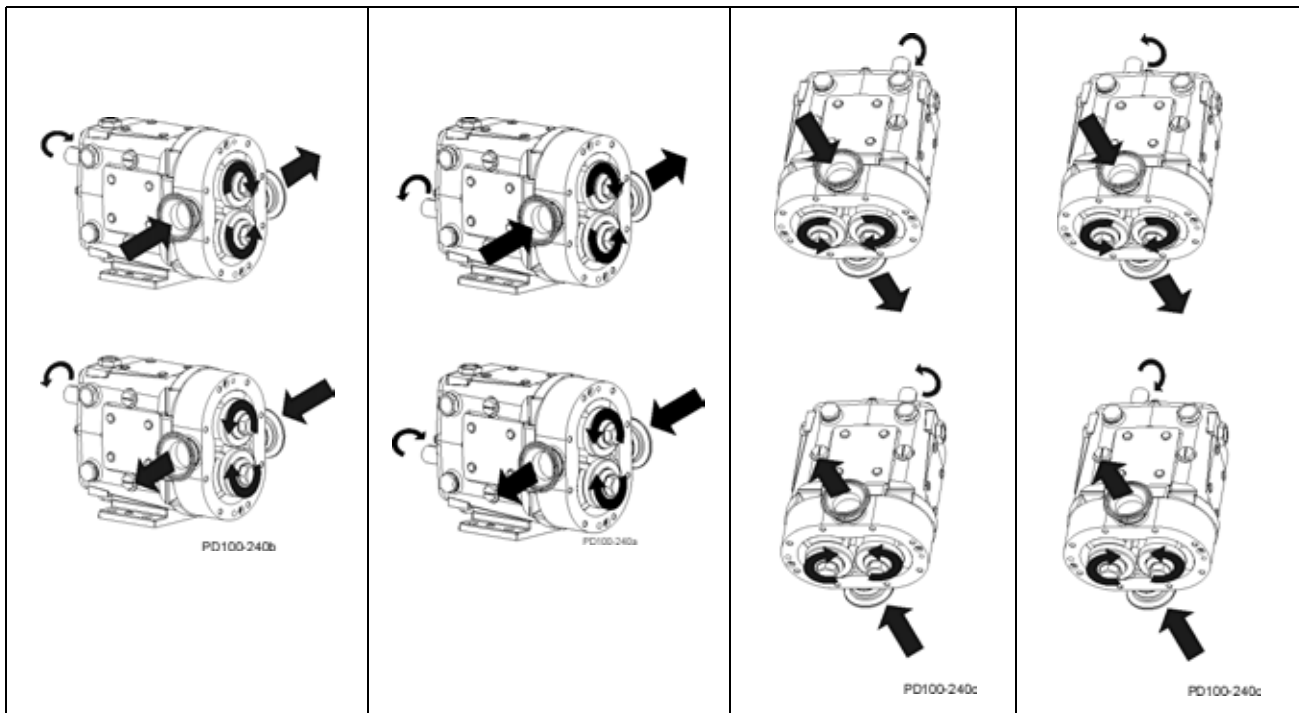

Figure 23 - Upper Shaft Drive Flow, Lower Shaft Drive Flow and Vertical Porting Flow and Pump Rotation (Liquid End Shown)

Operation



DANGER: The pump contains internal moving parts. DO NOT put hands or fingers into the pump body ports or drive area at any time during operation. To avoid serious injury, DO NOT install, clean, service, or repair the pump unless all power is off and locked out.



CAUTION: These pumps are positive displacement, low-slip design and will be severely damaged if operated with closed valves in discharge or inlet lines. The pump warranty is not valid for damages caused by a hydraulic overload from operation or start-up with a closed valve in the system.

Pre-Startup Checklist



CAUTION: Do not use this pump to flush a newly-installed system. Severe damage may occur to the pump and system if the pump is used to flush the system. **Remove the rotors during system flushing.**



WARNING: Full guards must be installed to isolate operators and maintenance personnel from rotating components. Guards are provided with Waukesha Cherry-Burrell pumps as part of a complete pump and drive package.



WARNING: Do not start a pump with seal flush unless the seal flush is installed and on.

1. Ensure that the pump is correctly installed as described in "Installation" on page 10. Review "Install Relief Valves" on page 12 and install relief valves as needed.
2. Check the coupling alignment. See "Check Coupling Alignment" on page 15.
3. Ensure that the pump and piping are clean and free of foreign material such as welding slag, gaskets, etc.
4. Ensure that all piping connections are tight and leak-free. Where possible, check the system with non-hazardous fluid.
5. Ensure that the pump and drive are lubricated. See "Lubrication" on page 18.
6. Ensure that all guards are in place and secure.
7. Double mechanical seals require adequate supply and flow of clean flushing fluids.
8. Ensure that all valves are open on the discharge side and a free flow path is open to the destination.
9. Ensure that all valves are open on the inlet side and fluid can fill the pump. A flooded suction installation is recommended.
10. Check the direction of pump and drive rotation to ensure that the pump will rotate in the proper direction. See "Check Pump Rotation" on page 16.

Startup Procedure

1. Start the pump drive. Where possible, start at a slow speed or jog.
2. Ensure that the liquid is reaching the pump within 60 seconds. If pumping does not begin and stabilize, check "Troubleshooting" on page 75.

Shutdown Procedure

1. Shut off power to the pump drive.
2. Shut off supply and discharge lines.

Emergency Shutdown Procedure

Emergency Shutdown Procedures should be documented by plant personnel after assessing system-wide requirements.

Maintenance

Important Safety Information

STOP ***DANGER:** The pump contains internal moving parts. DO NOT put hands or fingers into the pump body ports or drive area at any time during operation. To avoid serious injury, DO NOT install, clean, service or repair the pump unless all power is off and locked out.*

Before detaching port connections to the pump:

- Close the suction and discharge valves.
- Drain the pump and clean or rinse, if necessary.
- Disconnect or shut off the electrical supply and lock out all power.

Lubrication

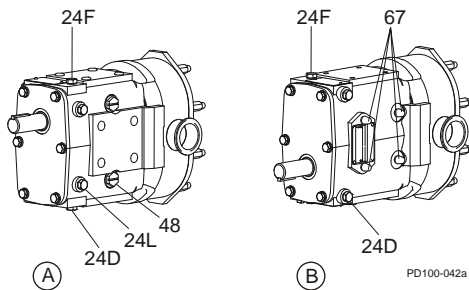

Figure 24 - Lubrication Points

Table 1: Callout table for Figure 24

A. Upper Shaft Drive Pump (Standard)
B. Lower Shaft Drive Pump (Optional)
24D. Oil Drain Plug
24F. Oil Fill Plug
24L. Oil Level Check Plug, Sightglass
48. Grease Clean-out Plug
67. Grease Fittings

Drive Lubrication

Refer to the manufacturer's manual shipped with the drive for proper drive lubrication and frequency.

Gears

Gears are factory-lubricated with gear oil at the quantity shown in Table 2. **Change the oil every 500 hours.**

Gear Oil Specification

ISO Grade 320, SAE 140 or AGMA Number 6EP.

Bearings

Bearings are factory-lubricated with grease. Re-grease them at the quantity shown in Table 2. **Grease the bearings every 250 hours.**

Excess grease will accumulate in the gear case and must be removed through the cleanout hole covered with a plastic plug (Figure 24, item 48).

Bearing Lubricant Grease

NLGI Grade No. 2, EP, Lithium-based lubricant is standard.

Table 2: Lubrication Quantities

Model	Oil Capacity (Gears)		Grease Quantity (per Bearing)	
	Top or Bottom	Side Mount	Front	Back
018UL	1.3 oz (40 ml)	3.3 oz (100 ml)	0.37 oz (11 cc)	0.13 oz (4 cc)
030UL, 050UL	2.0 oz (60 ml)	4 oz (120 ml)	0.60 oz (18 cc)	0.21 oz (6 cc)
060UL, 130UL	6.0 oz (170 ml)	9.5 oz (280 ml)	0.84 oz (25 cc)	0.76 oz (22 cc)
220UL, 224UL	11 oz (320 ml)	20 oz (600 ml)	1.33 oz (39 cc)	1.03 oz (30 cc)
320UL	17 oz (500 ml)	44 oz (1300 ml)	1.96 oz (58 cc)	1.16 oz (34 cc)

Maintenance Inspections



DANGER: The pump contains internal moving parts. DO NOT put hands or fingers into the pump body ports or drive area at any time during operation. To avoid serious injury, DO NOT install, clean, service or repair the pump unless all power is off and locked out.

Detecting wear in the early stages can reduce repair costs and down time. A simple “look-feel” inspection of the pump during breakdown cleaning is recommended to detect signs of trouble at an early stage.

A detailed maintenance inspection should be scheduled annually. See “Annual Maintenance” on page 22.

Refer to the “Maintenance Inspection Chart” on page 21 for possible causes and solutions to common issues discovered during inspection.

Inspection of Rotor Tips

Remove the cover (see “Remove Cover” on page 23) and check for metal-to-metal contact between the rotor wings. When contact is detected, repair or replace the pump.

Visually inspect the rotors for rotor-to-rotor contact and rotor-to-body contact. Manually rotate the pump drive shaft and ensure that the rotor-to-rotor clearance is equal on both sides as indicated in Figure 25. If contact occurs, see “Checking for Proper Clearance” on page 39 for proper clearances.

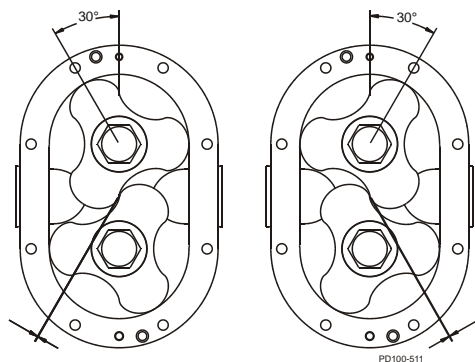

Figure 25 - Rotor-to-Rotor Tip Clearance

Inspection of Rotor and Shaft Spline

Visually inspect the rotor and shaft spline (Figure 26) for excessive wear; replace as necessary.

Inspection of Shaft

Visually inspect the shaft for twists or bends; replace it as necessary.

Inspection of Rotor Hub End

Visually inspect the rotor hub end (Figure 26, item A) for excessive wear; replace it as necessary. Each time rotors are removed, replace the o-rings on the hub.

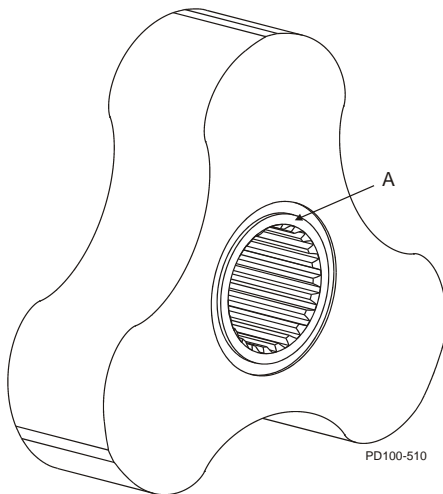

Figure 26 - Rotor

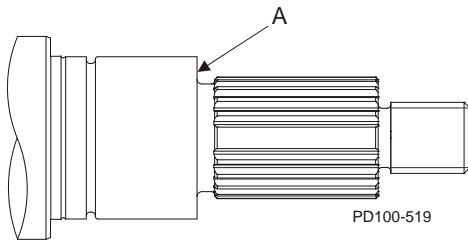

Figure 27 - Shaft Shoulder

Inspection of Shaft Shoulder

Visually inspect the shaft shoulder (Figure 27, item A) for excessive wear; replace it as necessary. If the shaft shoulder has a sharp edge, remove the edge with a file to prevent cutting the shaft o-ring on installation.

NOTE: Rotor hub and shaft shoulder wear are caused by operating with a loose rotor nut(s) for extended periods.

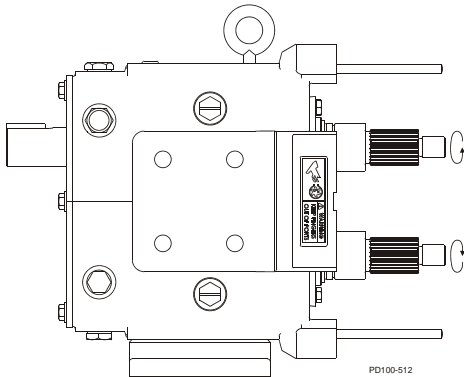

Figure 28 - Backlash Check

Inspection of Gears and Bearings

Gear backlash

With the fluid head and seals removed, feel for gear backlash by rotating either shaft by hand. The other shaft must engage immediately. Perform this check three times at 60-degree intervals. If play (backlash) is evident, remove the gear case cover, check the gear teeth for wear, and ensure that the gear is not loose on the shaft. If the gear teeth are worn, replace the gears. If the gear is loose on the shaft, inspect the shaft key and keyway; replace as necessary.

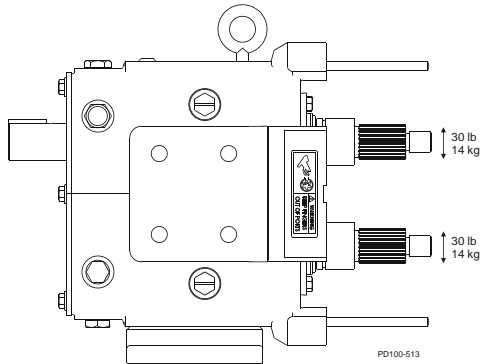

Figure 29 - Bearing Deflection Check

Check bearing condition

With the fluid head and seals removed, check the bearing condition by applying (by hand) an up or down force of approximately 30 lbs (14 kg). If movement of either shaft can be detected, the bearing may be failing. Also check the shaft movement forward or backward. If the bearing is failing, replace the bearing and review the lubrication section on page 18.

Maintenance Inspection Chart

Problem	POSSIBLE causes	possible Solutions
Rotor to rotor contact or uneven rotor to rotor clearance.	Hard object jammed into rotors and twisted shafts.	Replace shafts. Install strainers if necessary. Check and replace gears if necessary. Re-time rotors. (See "Timing Gear Assembly" on page 34.)
Rotor to body contact.	Loose rotor nut(s). Belleville-style washer(s) on backwards. Backface clearances not even. Bearings need replacing.	Torque rotor nut(s) properly. See "Torque Values" on page 44. Install belleville-style washers correctly. Verify backface clearances are even. Check and replace bearings.
Worn rotor or shaft splines.	Loose rotor nut(s). Belleville-style washer(s) on backwards.	Replace rotors and shafts. Torque rotor nut(s). See "Torque Values" on page 44. Install belleville-style washer(s) correctly.
Worn rotor hub end or shaft shoulder.	Loose rotor nut(s). Belleville-style washer(s) on backwards. Rotors slammed against shoulder when installed.	Torque rotor nut(s). See "Torque Values" on page 44. Install belleville-style washer(s) correctly. Replace rotors and shafts or shim front bearing(s) to maintain proper backface clearances.
Sharp edged shaft shoulder.	Loose rotor nut(s). Belleville-style washer(s) on backwards. Rotors slammed against shoulder when installed. Backface clearances not even.	Remove sharp edge with file to prevent cutting shaft o-ring. Verify backface clearances are even.
Gear backlash.	Lack of lubrication. Excessive hydraulic loads.	Check lubrication level and frequency. Reduce hydraulic loads. Torque locknut to specified torque values. See "Torque Values" on page 44. Check and replace gears if necessary.
Worn or broken gear teeth.	Lack of lubrication. Excessive hydraulic loads. Loose gear locknuts.	Check lubrication level and frequency. Reduce hydraulic loads. Torque locknuts to specified torque values. See "Torque Values" on page 44. Check and replace gears if necessary.
Loose gears.	Gear locknuts not torqued properly. Locking assembly not torqued properly. Worn gear key.	Torque gear nut to specified torque value. See "Torque Values" on page 44. Check and replace gears if necessary. Inspect and replace gear key, shaft keyway and shaft, replace as necessary.
Loose bearings, axially or radially.	Lack of lubrication. Excessive hydraulic loads. Product or water contamination.	Check lubrication level and frequency. Reduce hydraulic loads. Ensure no excess grease build-up. Replace bearings if necessary.
Damaged front grease seals.	Seal may be old and worn. No grease on lips to lubricate. Shaft worn under seals.	Replace seals. Properly lubricate with grease when installing. Inspect shaft surface under seals.
Damaged rear oil seals.	Seal may be old and worn. No grease on lips to lubricate. Shaft worn under seals. Not centered on shaft when installed.	Replace seals. Properly lubricate with grease when installing. Inspect shaft surface under seals.

Annual Maintenance



DANGER: The pump contains internal moving parts. DO NOT put hands or fingers into the pump body ports or drive area at any time during operation. To avoid serious injury, DO NOT install, clean, service or repair the pump unless all power is off and locked out.

At least annually, perform the procedures and corrective measures outlined in “Maintenance Inspections” on page 19, in addition to the following preventive maintenance:

- Check the bearings with a dial indicator for shaft radial play. If the deflection is equal to or greater than rotor-to-body diametrical clearance (“Checking for Proper Clearance” on page 39), replace the bearings.
- Remove the gear cover and inspect the gears for wear, backlash and looseness. Loosen and torque the gear retaining nuts to proper torque (see “Torque Values” on page 44).
- Thoroughly inspect the rotors for worn splines and hub wear.
- Review the performance record on pump, and check the radial and backface clearances to determine the wear and effect on performance. See “Standard Rotor Clearance” on page 39. Adjustment to the operating speed can compensate for wear in some applications.



CAUTION: When replacing the bearings or shafts in the field, take care to correctly position the shaft by shimming to maintain sufficient running clearances between the rotor faces and pump body faces (backface and cover face). See “Standard Rotor Clearance” on page 39.

Cleaning

Determine the pump cleaning schedule on-site for materials being processed and plant maintenance schedule.

To disassemble the fluid head, see “Fluid Head Disassembly” on page 23. Remove and clean the cover o-ring, pump seals and rotor nut assembly. Inspect and replace them as necessary.

NOTE: Always replace the rotor nut o-rings and rotor hub o-rings when reassembling the pump. If the area behind these seals becomes soiled, contact WCB Application Engineering for a specific cleaning and sanitizing procedure validated to remove bacteria.

In applications where material can harden in the pump during shutdown, a CIP cleaning, flush or disassembly of the fluid head and manual cleaning is strongly recommended.

Fluid Head Disassembly



DANGER: The pump contains internal moving parts. DO NOT put hands or fingers into the pump body ports or drive area at any time during operation. To avoid serious injury, DO NOT install, clean, service, or repair the pump unless all power is off and locked out.



DANGER: To avoid serious injury, shut off and drain the product from the pump before disconnecting the piping.

Table 3: Callout table for Figure 31

1. Body	2. Cover
9. Rotor	11. Cover Nut
26. Rotor Nut	26A. Rotor Nut O-ring*
26B. Belleville-style washer	26C. Retainer O-ring
26D. Rotor O-ring*	36. Cover O-ring
45. Body Retaining Cap Screw	
* Discard the o-rings from the rotor and rotor nut; these are intended for one-time use only.	



Figure 30 - Blocking Dowel

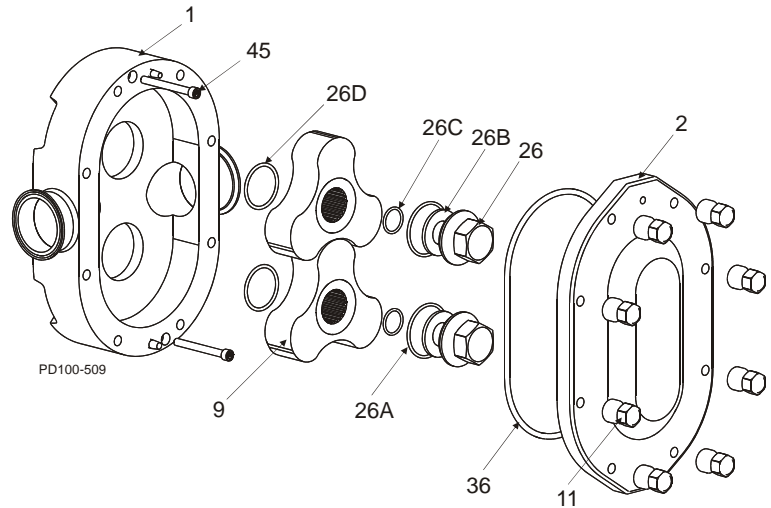

Figure 31 - Exploded View of Fluid Head

Blocking Dowels	
Pump Model	Dowel Diameter
018UL	7/8 to 1 in (22 to 25 mm)
030UL, 050UL	1-1/4 to 1-3/8 in (32 to 35 mm)
060UL, 130UL	1-11/16 in (43 mm)
220UL	2-3/8 in (60 mm)
320UL	3 in (76 mm)

Remove Cover

1. Remove the cover nuts (Figure 31, item 11) from the cover (item 1).
2. Using a soft hammer, tap the cover (Figure 31, item 2) off the body studs and dowel pins.
3. Place the cover on a protected surface with the finished surfaces up.
4. Remove and inspect the cover o-ring (Figure 31, item 36).

Remove Rotor Nut Assemblies

1. Use a blocking dowel (Figure 30) to keep the rotors from turning when removing the rotor nuts.

NOTE: When working on a rotor, always use a dowel to block the rotor against the body, not against the other rotor. See Figure 32.

2. Using a wrench, remove the rotor nuts, belleville-style washers, rotor nut o-rings, and rotor o-rings. See Figure 32.



Figure 32 - Loosening Rotor

Remove Rotors

1. Using only your hands, remove the rotors and place them on a clean, protected surface to prevent damage to close tolerance parts.

If the rotors cannot be removed by hand:

- Use plastic or hardwood dowels to pry out the rotors.
- Remove the body retaining cap screws. Tap the body forward and backward with a soft hammer to loosen the rotors.
- If necessary, use a puller. Use care with the puller or dowels to avoid damaging the rotors.

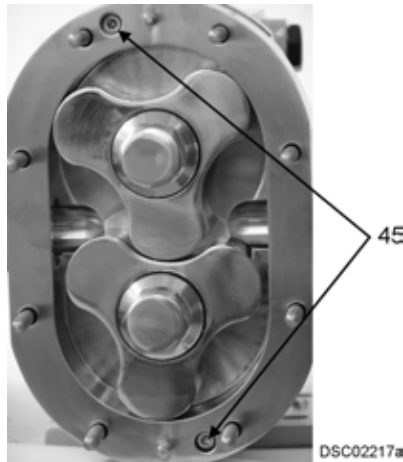

Figure 33 - Location of Cap Screws

Remove Pump Body

1. Remove the two body retaining cap screws (Figure 33, item 45).
2. Using a plastic mallet, tap the body off the gear case, dowel pins and body studs.
3. Slide the body straight off the body studs to prevent damaging the mechanical seal parts.
4. Place the body on a protected surface with the seals facing up to protect the seals.

Remove Mechanical Seal

1. Remove the stationary seals from the pump body, using care not to damage the seals on the three body pins.
2. Remove the mechanical seal springs and o-rings on the stationary seals.
3. Inspect the three seal body pins for damage and repair or replace them as necessary. If the pins are loose, replace them with new ones.
4. Remove the rotary seal from each shaft. Use caution not to damage the seals during removal. Use a steady, even force behind the seal in multiple locations. After the rotary seals are removed, remove and replace the shaft o-rings. Before installing the new o-rings, inspect the shaft's o-ring groove(s) for damage and repair or replace them if required.
5. Inspect the flats on the shaft shoulder and repair or replace the shafts if required.

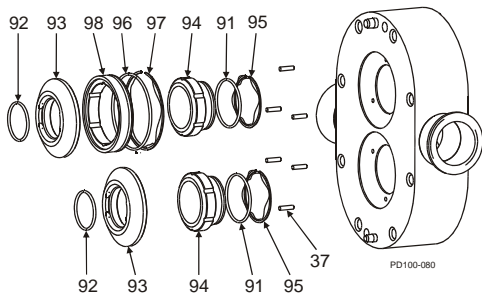

Figure 34 - Single (Bottom) and Double (Top) Mechanical Seal

Table 4: Callout table for Figure 34

37. Stop Pin
91. Inner Seal O-ring
92. Shaft O-ring
93. Seal Seat
94. Inner Seal
95. Inner Wave Spring
96. Outer Seal O-ring
97. Outer Wave Spring
98. Outer Seal

Gear Case Disassembly



DANGER: To avoid serious injury, DO NOT install, clean, service, or repair the pump unless all power is off and locked out.



DANGER: To avoid serious injury, shut off and drain the product from the pump prior to disconnecting the piping.

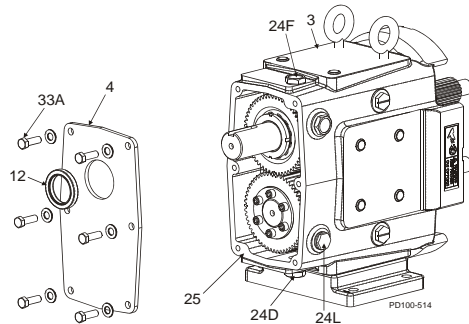

Figure 35 - Remove Gear Case Cover

3. Gear Case	24F. Oil Fill Plug
4. Gear Case Cover	24L. Oil Level Check Plug, Sight glass
12. Oil Seal	25. Silicone Sealant
24D. Oil Drain Plug	33A. Cap Screw

Remove Gear Case Cover

1. Remove the oil drain plug (Figure 35, item 24D); drain the oil.
2. Remove the cap screws from the gear case (item 33A).

NOTE: Place tape over the shaft keyway to prevent damage to the lip seal.

3. Pull the cover (item 4) off the shaft extension. If the cover sticks, use a soft hammer to loosen it.
4. Remove the silicone sealant (item 25) from the gear case and cover.
5. Using an arbor press, remove the oil seal (item 12) from the cover. Discard the used oil seal.

6. Straighten the tab on the lock washer (Figure 36, item 39).

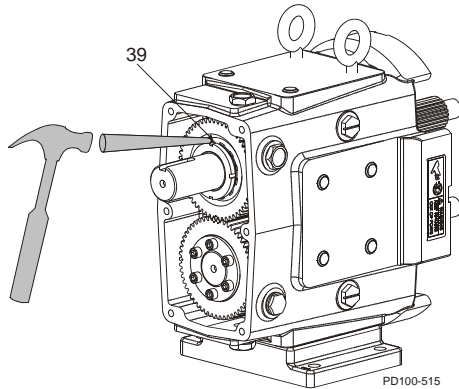

Figure 36 - Straighten Lock Tab on Lock Washer

Remove Shaft

1. Prevent the shafts from turning by placing a wedge (item A) between the gears (Figure 37, item A). Use a spanner wrench or drift punch to remove the gear lock nut. The gears will be removed later.

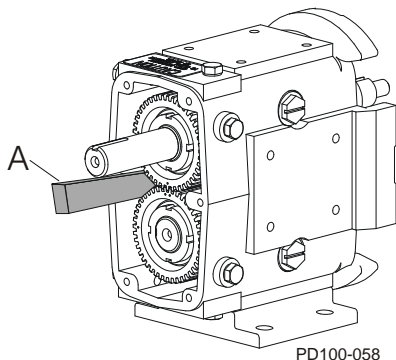

Figure 37 - Block Shaft Rotation



Figure 38 - Remove Gear and Locking Assembly

2. Loosen the locking screw or screws on the locking assembly and tap them lightly with a mallet (or use thread jacking holes) to loosen the gear. Remove the gear and locking assembly (Figure 38).

NOTE: Wrap the liquid end shafts with tape to prevent damage to the threads.

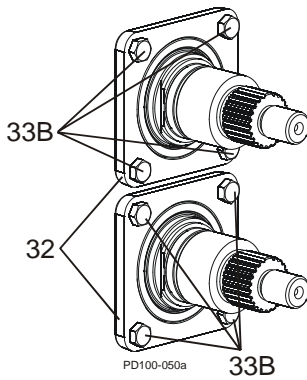

Figure 39 - Remove Bearing Retainers

3. Remove the front bearing retainer bolts (Figure 39, item 33B) and pull off the bearing retainers (item 32). (If a retainer is stuck, leave it in place; it will press out when the shaft is removed.)

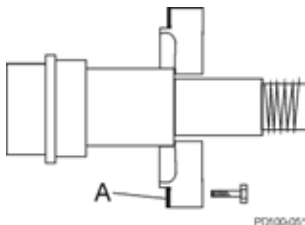

Figure 40 - Remove Sealant from Retainer

4. Scrape the silicone sealant (Figure 40, item A) from the bearing retainer and gear case.

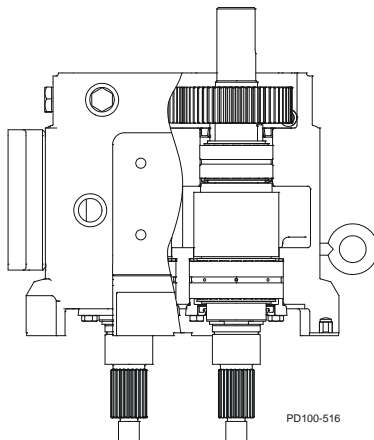

Figure 41 - Press Shafts from Gear Case

5. Place the gear case on an arbor press with the liquid end facing down. Protect the shaft ends with a wood or plastic block, and press the shafts out of the gear case (Figure 41).
6. Remove the upper timing gear and spacer from the drive end.

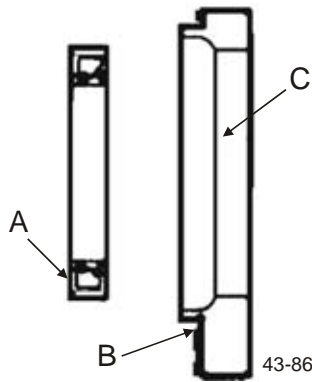

Figure 42 - Press out grease seal

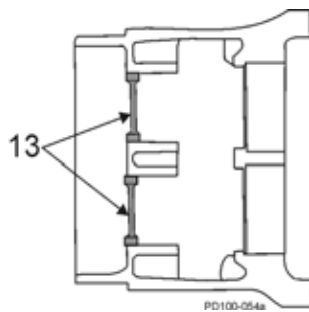

Figure 43 - Remove rear oil seals

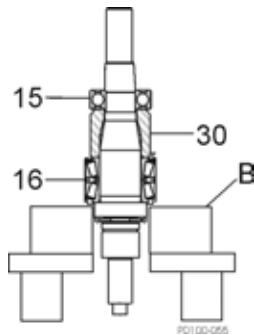

Figure 44 - Remove Bearings From Shaft

7. Scrape the silicone sealant (Figure 42, item B); then press out and discard the grease seal (item A) from the front bearing retainers (item C).
8. Remove the shims. If the shafts and bearings will be reused, identify the shims and bearings that belong with each shaft.

9. Press out and discard both rear oil seals in the gear case (Figure 43, item 13).

10. Use a hydraulic press and V-blocks (Figure 44, item B) to remove the bearings (items 15 and 16) and spacer (item 30).

NOTE: Make sure both ends of the shaft are protected when removing the shaft.

Shaft Assembly

Front Bearing Assembly

NOTE: The following instructions cover assembly of a six-piece front bearing assembly. For a four-piece assembly, only one spacer and cup is used.

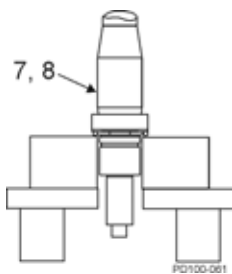

Figure 45 - Grease shaft

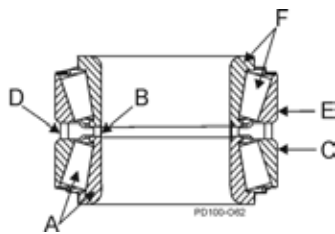

Figure 46 - Bearing assembly

Table 5: Callout table for Figure 46

A. Lower Cone / Roller Assembly	D. Outer Spacer
B. Inner Spacer	E. Upper Cup
C. Lower Cup	F. Upper Cone / Roller Assembly

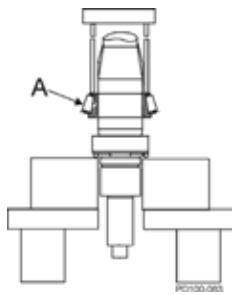

Figure 47 - Press Lower Cone onto Shaft

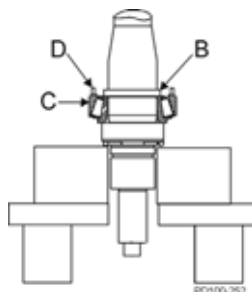

Figure 48 - Install Inner & Outer Spacer and Lower Cup

1. Lubricate the front bearing area of the shaft (Figure 45, item 7, 8) with oil or grease. See "Lubrication" on page 18. Place the shaft and bearing assembly upright in a hydraulic press with the liquid end facing down.

2. Unwrap the front bearing assembly.

NOTE: DO NOT interchange the parts of one bearing assembly with another. The parts are precisely matched during manufacturing and must be installed as a matched assembly. See Figure 46.

3. Lift the lower cone and roller assembly (Figure 47, item A) out of the bearing stack and place it on the shaft with the radius facing down. Press it onto the shaft until it is seated against the shaft shoulder. **Press only on the inner cone.**

4. Place the inner spacer (Figure 48, item B) over the shaft onto the lower cone and roller assembly.
5. Place the lower cup (item C) over the lower cone and roller assembly, keeping the cup opening toward the assembly.
6. Place the outer spacer (item D) over the shaft and onto the lower cup.

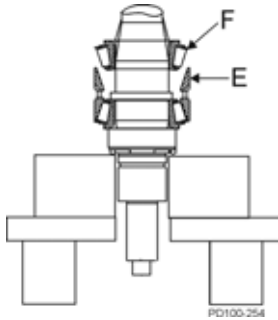

Figure 49 - Install Upper Cup & Upper Cone

7. Place the upper cup (Figure 49, item E) on top of the outer spacer.
8. Lubricate the remaining upper cone and roller assembly (Figure 49, item F) with oil or grease and slip it over the shaft with the roller radius facing up. Press it onto the shaft and into the upper cup.

NOTE: Make sure all the components are aligned before pressing. **Press only on the inner cone.**

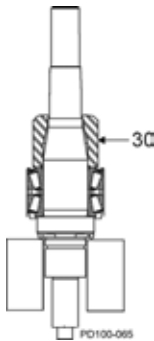

Figure 50 - Install Bearing Spacer

9. Install the bearing spacer (Figure 50, item 30).

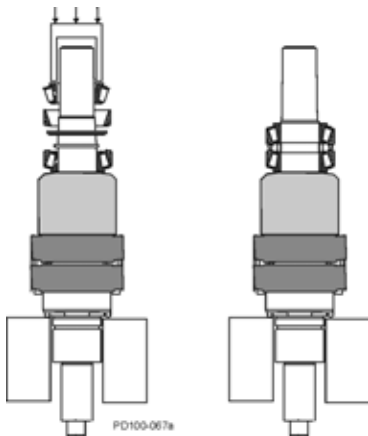

Figure 51 - Rear Tapered Roller Bearing Assembly

Rear Bearing Assembly

Models 018, 030 and 050 use a single ball bearing assembly for the rear bearing. All other models use a tapered roller bearing assembly similar to the front bearings.

1. Unwrap the rear bearing assembly. See Figure 51.

NOTE: DO NOT interchange the parts of one bearing assembly with another. These parts are precisely matched during manufacturing and must be installed as a matched assembly.

- **For models with ball bearing assemblies:**
Lubricate the shaft inner bearing race with oil or grease. Press the bearing into place. The shielded side of the bearing fits against the bearing spacer. Press only on the inner race.
- **For models with tapered roller bearing assemblies:**
Lubricate the shaft bearing area with oil or grease. Follow the "Front Bearing Assembly" procedures on page 28.

NOTE: Heating bearings is **NOT** recommended. If bearings are heated, do not exceed 300°F (149°C).

Gear Case Assembly

Suggested Shims		
Model	Standard Shaft	Replacement Shaft
018UL	0.113 in (2.87 mm)	0.110 in (2.79 mm)
030UL, 050UL	0.105 in (2.27 mm)	0.102 in (2.59 mm)
060UL, 130UL	0.093 in (2.36 mm)	0.088 in (2.24 mm)
220UL	0.115 in (2.92 mm)	0.110 in (2.79 mm)
320UL	0.125 in (3.18 mm)	0.120 in (3.05 mm)

Shimming

1. When installing the shafts in the gear case, shim behind the front bearing to achieve the proper backface clearance between the back of the rotors and the body. The backface clearance must be equal for both rotors to prevent the rotors from hitting each other during operation.

NOTE: Do not install any bearing retainer sealant, gears, or gear locknuts until the correct shimming has been verified.

2. **If the shafts and/or the bearings do not need to be replaced, and the shims are marked to indicate which shaft and bearing they match,** a shim adjustment probably will not be necessary. Reuse the existing tagged shims, shafts and bearings in the same gear case bores.
3. **If the existing shims are lost and/or a standard shaft is used,** determine the required shims from the “Suggested Shims” chart.
4. **If necessary, calculate the required shims for the replacement shafts, bearings or both** by referring to Figure 52; carry the measurements and calculations to three decimal places (i.e. 0.059).

NOTE: Arrange with thicker shims on the outside of the shim pack.

Table 6: Callout table for Figure 52

B. Front face of gear case to back of bearing bore
C. Shaft shoulder to back of bearing race
D. Body thickness
E. Depth of rotor cavity

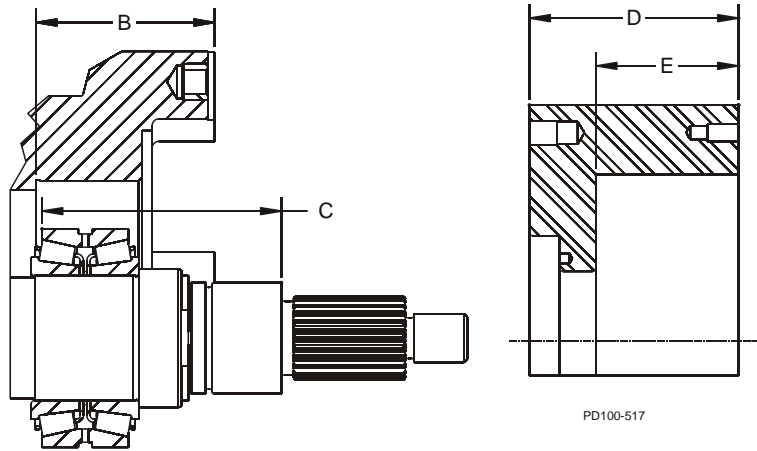

Figure 52 - Measurements for calculating required shims

5. Determine the shim thickness required for the front bearing:
 - Measure “B” in gear case and “C” on shaft.
 - Measure “D” and “E” on body.
 - Determine the proper backface clearance. Refer to Table 8, “Standard Rotor Clearance,” on page 39.
 - Required Shims = Backface clearance - C + B + D - E.
6. Place the shims in the body, resting against the shoulder in the front bearing bore.

Install Shaft

1. With the shims in place, install the shaft assembly in the front bearing bore with the fluid end facing up.
Ensure that the shaft is installed in its original location.

NOTE: The shafts may need to be removed for a final shim adjustment.

2. Lubricate the outside diameter of the bearing.
3. Press the shaft into place until it is seated against the shim pack. **Press only against the outer race of the bearing.**

NOTE: A tube of the same diameter as the outer race of the bearing can also be used to press the shaft into place.

4. Temporarily secure the shaft/bearing in the gear case with the bearing retainers to aid in checking clearances.
DO NOT install silicone sealant at this time.

5. The bearing retainer must rest firmly against the bearing. Leave a 0.010 to 0.050 in (0.25 to 1.25 mm) clearance (Figure 53, item A) between the back of the bearing retainer (item B) and the front of the gear case (item C). If this clearance is not met, place shims between the bearing and the retainer.

6. Temporarily mount the body on the gear case.
7. Secure the body to the gear case using body retaining screws.
8. Install the rotors and rotor nuts. The rotor nut o-rings, belleville-style washers and retainer o-rings are not required at this time.

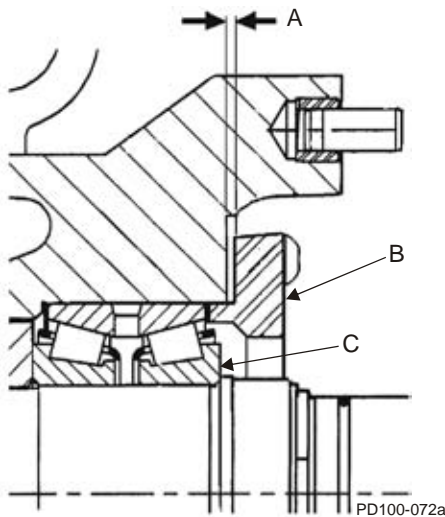

Figure 53 - Bearing Retainer Clearance

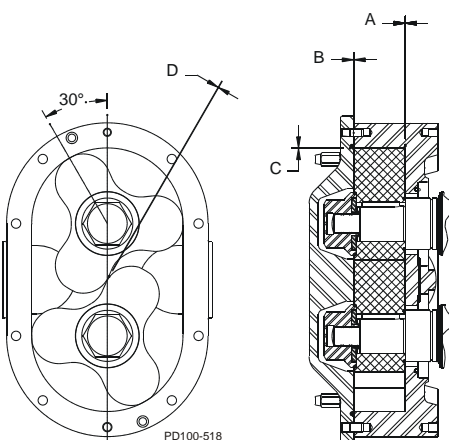

Figure 54 - Measure Clearance

NOTE: "B" dimension is below the face of the casing.

9. Measure the rotor backface clearance (Figure 54, item A) through the port or from the front. For optimum pump operation, the backface clearance for both rotors must be the same and must be ± 0.0005 " of the value found in Table 8, "Standard Rotor Clearance," on page 39.
10. Check the rotor front face clearance (Figure 54, item B).
11. Check the rotor to body clearance (Figure 54, item C).
12. Check these clearances against Table 8, "Standard Rotor Clearance," on page 39. For non-standard rotors, check with the factory.

NOTE: If the process uses special clearance rotors, contact WCB with the serial number of pump for clearance tolerance values.

13. If the backface clearance is not met, disassemble the pump and adjust the shimming to achieve the correct backface clearance.
14. If the rotor-to-body clearance is not met or is uneven, contact Waukesha Cherry-Burrell technical services for proper adjustment procedures.

15. After obtaining the proper clearance, remove the rotor nuts, rotors, body, and bearing retainers.
16. Grease the front and rear bearings through the grease fittings until the grease is visible around the bearing assemblies. The amount of grease required is listed in "Grease Quantity (per Bearing)" on page 18. Rotate the shafts while greasing them to disperse the grease.
17. Lubricate the grease lip seals.

NOTE: The compression or garter spring should be located toward the sealed area or inside of the gear case.

18. Coat the retainer flanges with silicone sealant (Figure 55, item A). (Gore-Tex[®] sealing tape can be used on silicone-free models.) The grease seal (item 14) should be flush with the front of the bearing retainer. On the 030 models, the grease seal is positioned against the step on the inside diameter of the retainer.

19. Install the bearing retainers (Figure 55, item 32).

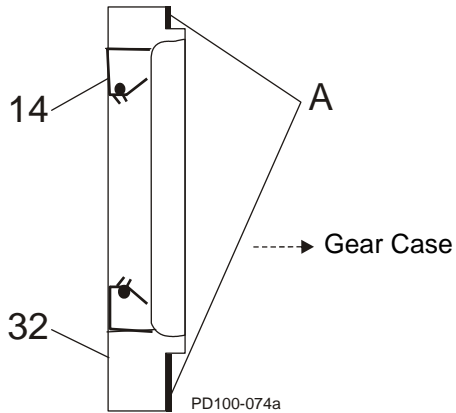

Figure 55 - Install Bearing Retainer

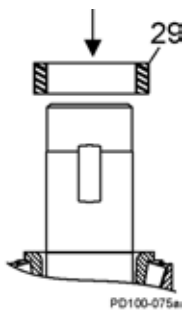

Figure 56 - Install Rear Seal

Install Rear Seal Assembly and Locknuts

1. Install the gear spacer on the drive shaft (Figure 56, item 29).
2. Lubricate the inside diameter of the rear gear case oil seals with oil or grease. See "Lubrication" on page 18.

NOTE: Place tape or other material over the shaft end to prevent cutting the seal during installation

3. Install the rear gear case oil seals on the shafts with the seal lip facing toward the gear case.
4. Press the seals into place. See Figure 57.

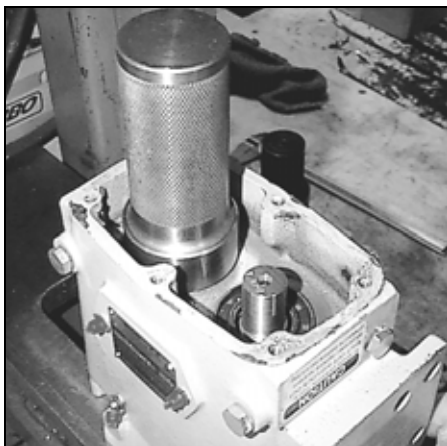

Figure 57 - Press seals into place



Figure 58 - Install rotor nut assembly

5. Place the pump upright. Insert the rotor on the short shaft. Install the rotor nut assembly to hold the rotor in place. Hand tighten only.

NOTE: Place a plastic rod or wood dowel across the rotor to keep the short shaft from turning.



Figure 59 - Install locknut sleeve

6. Turn the gear case around. Apply anti-seize to the locknut sleeve (Figure 59, item A) and install it on the short shaft.
7. Apply a special tool and use a torque wrench to tighten to specifications. (See "Torque Values" on page 44.)

Timing Gear Assembly

1. Install the timing gear on the drive shaft.



Figure 60 - Install timing gear on drive shaft

2. Place the timing gear on the short shaft with the solid side facing in.

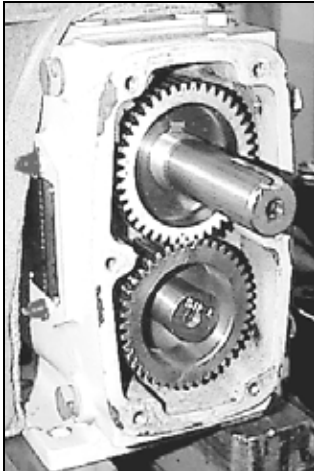

Figure 61 - Install timing gear on short shaft

3. Lubricate the locking assembly (Figure 62, item A) with light oil and slide it onto the short shaft and fully into the gear. The bolt heads should face out.

If the locking assembly was exposed to gear lubricant, remove and clean the locking assembly:

- Remove the locking assembly and disassemble it by removing the bolts.
- Clean the parts, removing all oil residues.
- Spray the locking assembly components, including the bolts, with light oil. (Do not use oils containing Molybdenum Disulfide.)
- Re-assemble the locking assembly and slide it onto the short shaft and fully into the gear.

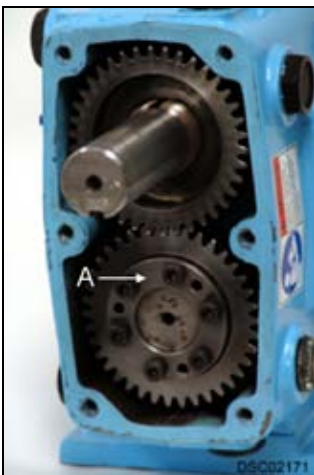

Figure 62 - Slide locking assembly on short shaft

NOTE: The release threads of the inner ring must be positioned opposite to the un-drilled spaces of the outer ring.

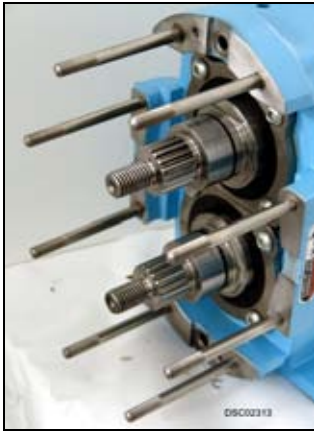

Figure 63 - Body studs

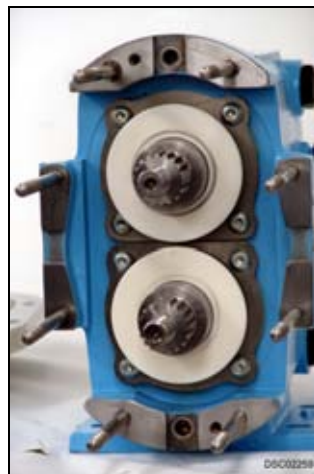

Figure 64 - Install seals



Figure 65 - Press seal assemblies into body

4. Hand-tighten the locking assembly bolts in an alternating pattern.
5. If replacing the body studs, apply anti-seize and carefully thread all the studs into the body. Tighten the studs using a wrench on a double nut or a nut driver.
6. Install the seals with the beveled side facing toward the gear case.
7. Press the seal assemblies into the back of the body.

8. Place the body on the studs and push it against the gear case.



Figure 66 - Place body on studs

9. Lubricate the two socket head retaining bolt threads with anti-seize, install, and tighten the bolts to the body.

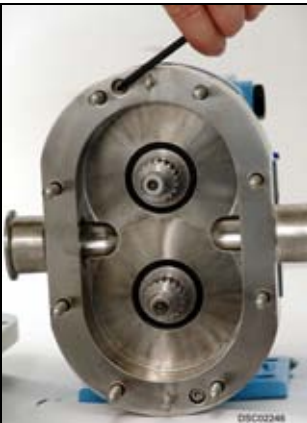

Figure 67 - Tighten bolts

10. Install the rotors.



Figure 68 - Install rotors



Figure 69 - Tighten rotor nuts

11. Insert a plastic or wood rod between the rotors. Place the rotor nut assembly on the top rotor shaft and tighten it to the proper torque specs. (See "Torque Values" on page 44.)
12. Place the rotor nut assembly on the bottom rotor shaft and place the rod between the rotors. Tighten the bottom rotor nut to the proper torque specs. (See "Torque Values" on page 44.)



Figure 70 - Tighten and torque drive shaft

13. Turn the pump around. Insert an aluminum or brass rod between the gear teeth to prevent it from turning. Place a tabbed washer and lock nut on the drive shaft gear. Tighten and torque to the value shown on page 44.



Figure 71 - Bend tab into locknut slot

14. Use a small, straight-bladed screwdriver to bend one tab into the locknut slot.

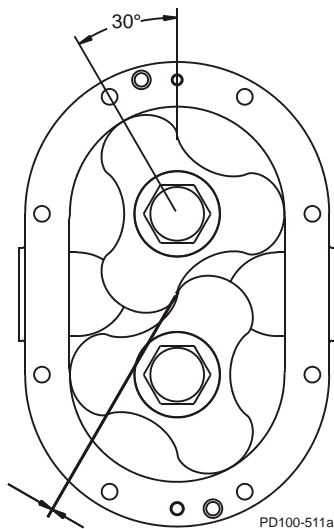

Figure 72 - Align rotors



Figure 73 - Tighten socket head screws

15. Tighten the locking assembly bolts evenly by hand so that the locking assembly begins to grip the shaft.
16. Align the rotors to attain the specified clearance between the wings. See Table 8, "Standard Rotor Clearance," on page 39.
17. Insert an aluminum or brass rod between the gear teeth to prevent it from turning.
18. Using a torque wrench, tighten the locking assembly bolts in an alternating pattern. Turn each bolt only 90 degrees at a time until the Step 1 torque value is reached, as referenced below in Table 7, "UL Locking Assembly Data."
19. After reaching the Step 1 torque value, double-check each bolt for the correct torque.
20. Repeat the process above until the Final torque value is reached, as referenced below in Table 7.
21. Check the rotor clearance and adjust if needed. See Table 8, "Standard Rotor Clearance," on page 39.

Table 7: UL Locking Assembly Data

Model	Screw Hex Size	Qty.	Step 1 Torque	Final Torque
018UL	5 mm	8	60 in-lbs	126 in-lbs
030UL, 050UL	5 mm	6	75 in-lbs	158 in-lbs
060UL, 130UL	6 mm	6	180 in-lbs	378 in-lbs
220UL	6 mm	6	180 in-lbs	378 in-lbs
320UL	6 mm	8	180 in-lbs	378 in-lbs

Checking for Proper Clearance

Waukesha Cherry-Burrell pumps are designed with close running clearances. Backface clearances are set with shims during assembly.

Shafts are positioned with shims behind the front bearing and locked into the gear case with bearing retainers. Rotors lock against shaft shoulder. The clearance between the body backface and the back of the rotor wing is called backface clearance.

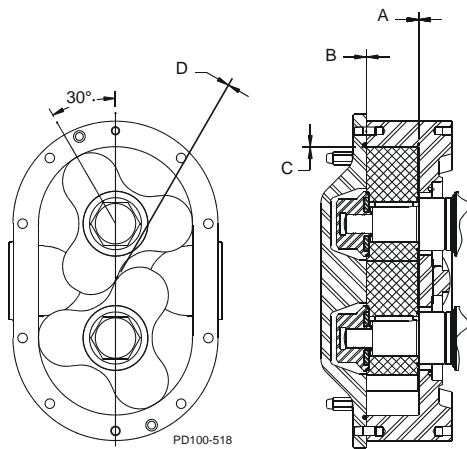

Figure 74 - Clearance Measurements

NOTE: “B” dimension is below the face of the casing.

1. Measure the rotor backface clearance (Figure 74, item A) through the port or from the front. For optimum pump operation, the backface clearance for both rotors must be the same and must be $\pm .0005$ " of the value found in Table 8, below.
2. Measure the rotor front face clearance (Figure 74, item B).
3. Measure the rotor to body clearance (item C).
4. Check the measured clearances against the recommended Standard Rotor Clearances in Table 8.
5. If the clearances are greater than the values listed and desired performance is not achieved, contact Waukesha Cherry-Burrell technical services for guidance.

Table 8: Standard Rotor Clearance

Model	A Back Face	B Front Face	C Rotor to Body	D Rotor to Rotor
018UL	0.002 in 0.05 mm	0.005 in 0.13 mm	0.002 in 0.05 mm	0.015 / 0.010 in 0.381 / 0.254 mm
030UL, 050UL	0.003 in 0.08 mm	0.005 in 0.13 mm	0.003 in 0.08 mm	0.020 / 0.010 in 0.508 / 0.254 mm
060UL, 130UL	0.004 in 0.10 mm	0.008 in 0.2 mm	0.005 in 0.13 mm	0.025 / 0.015 in 0.635 / 0.381 mm
220UL	0.005 in 0.13 mm	0.008 in 0.2 mm	0.008 in 0.20 mm	0.035 / 0.025 in 0.889 / 0.635 mm
320UL	0.006 in 0.15 mm	0.011 in 0.28 mm	0.010 in 0.25 mm	0.037 / 0.028 in 0.940 / 0.711 mm

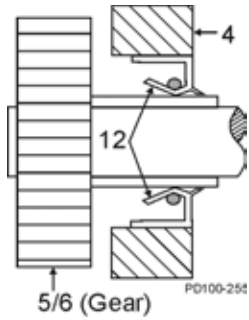

Figure 75 - Orientation of Oil Seal

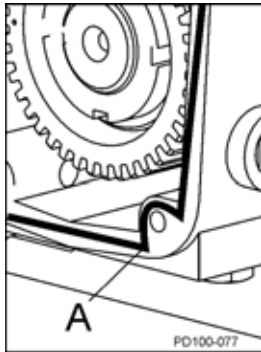

Figure 76 - Sealant Placement

Install Gear Case Cover

1. Lubricate the inside diameter of the new oil seal.
2. Press the new oil seal (Figure 75, item 12) into the gear case cover (item 4) flush with outside face, with the spring facing in.

3. Apply silicone sealant to the back of the gear case. (Gore-Tex[®] sealing tape can be used on silicone-free models.) Place the tape on the inside of the screw holes (Figure 76, item A).
4. Tape the shaft end to prevent cutting the seal on the keyway. Mount the cover assembly on the gear case. Secure it with cap screws and washers.
5. Remove the tape from the shaft end.

NOTE: Make sure that the shaft is centered in the lip seal before securing the cap screws.

6. Install the oil drain plug.
7. Fill the gear case with gear oil to the proper level. Refer to "Lubrication" on page 18.

Fluid Head Assembly

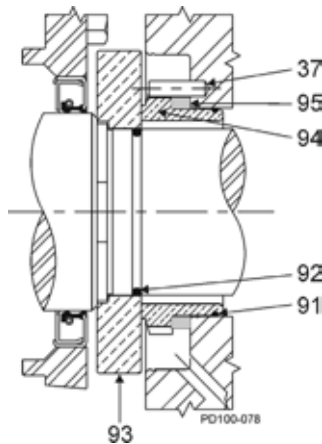

Figure 77 - Single Mechanical Seal

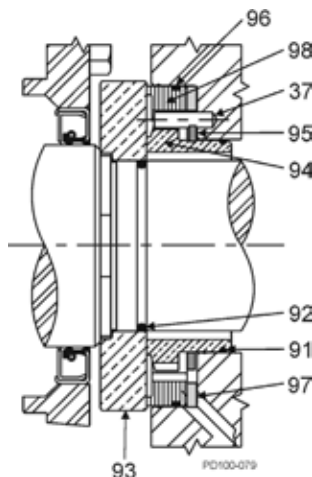

Figure 78 - Double Mechanical Seal

Table 9: Callout table for Figure 77, Figure 78, and Figure 79

37. Stop Pin
91. Inner Seal O-ring
92. Shaft O-ring
93. Seal Seat
94. Inner Seal
95. Inner Wave Spring
96. Outer Seal O-ring
97. Outer Wave Spring
98. Outer Seal

Install Mechanical Seal

1. Lubricate the shaft o-ring (Figure 77, item 92) with a lubrication compound compatible with the o-ring material and process fluid(s). Place the o-ring on the shaft.
2. Install the rotating seal seat (item 93) on the shaft. Align the drive flats on the seat with the drive flats on the shaft.
3. Push the seat squarely against the shaft shoulder.
4. Install the inner wave spring (item 95) onto the inner seal (item 94).
5. Lubricate the inner seal o-ring (item 91) with a lubrication compound compatible with the o-ring material and process fluid(s). Install the inner seal o-ring into the groove of the inner seal.
6. Place the inner seal into the back of the pump body. Ensure that the notches are aligned in the inner seal with the stop pins in the body. Press firmly and evenly into place.
7. If a double mechanical seal is used, install the outer wave spring (Figure 78, item 97) in the body and the outer o-ring (item 96) in the outer seal groove (item 98). Place the outer seal in the pump body around the inner seal, aligning the notches in the outer seal with the stop pins in the body.
8. Inspect the seal faces for cleanliness. Ensure that the faces have no nicks or scratches. Lubricate the seal faces with a lubricant compatible with the process fluid(s).
9. Perform steps 1 through 5 on both shafts.

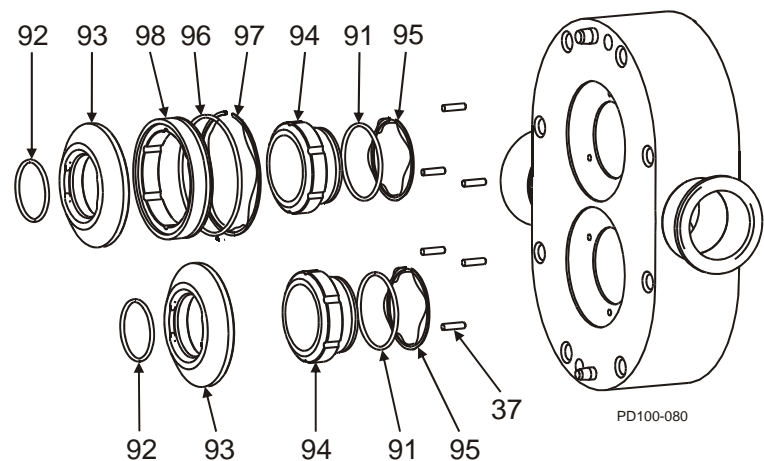

Figure 79 - Single (Bottom) and Double (Top) Mechanical Seal

Install Pump Body

1. Match the large and small dowel pin sizes on the pump body with the dowel pin holes in the pump gear case.

2. Install the body (Figure 80, item 1) to the gear case assembly, aligning the body with the body studs. Avoid damaging the seals as the body is drawn over the shafts.
3. Secure the body to the gear case using two cap screws (Figure 80, item 45).

Install Rotors

1. Lubricate the o-ring (Figure 80, item 26D) with a lubrication compound compatible with the o-ring material and process fluid(s).
2. Install the new rotor hub o-rings (item 26D) into the groove in the rear of the rotor.
3. Install the rotors (item 9) onto the shafts with the o-ring toward the gear case.

Table 10: Callout table for Figure 80

1.	Body
2.	Cover
9.	Rotor
11.	Cover Nut
26.	Rotor Nut
26A.	Rotor Nut O-ring*
26B.	Belleville-style washer
26C.	Retainer O-ring
26D.	Rotor Hub O-ring*
26E.	Rotor Key
36.	Cover O-ring
45.	Body Retaining Cap Screw

*Discard the rotor hub and rotor nut o-rings; these are intended for one-time use only.

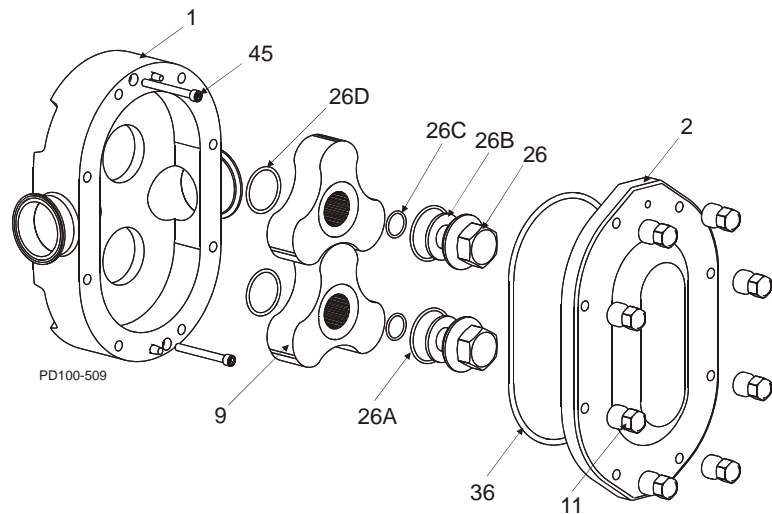

Figure 80 - Exploded View of Fluid Head

Install Rotor Nut Assemblies

1. Install the belleville-style washer (Figure 80, item 26B) into rotor nut with raised side of washer toward rotor nut.
2. Place the retainer o-ring (item 26C) into rotor nut to retain the belleville-style washer. The washer should not be tight against the o-ring.
3. Lubricate the new rotor nut o-ring (item 26A) with a lubrication compound compatible with the o-ring material and process fluid(s). If the o-ring is not lubricated it will pucker when tightening the rotor nut.
4. Install the rotor nut o-ring onto the rotor nut.
5. Before assembling the rotor nuts, apply an anti-seize compound to the shaft threads.
6. Use a blocking dowel to prevent the rotors from turning during installation. See "Blocking Dowels" on page 23 for rotor blocking dowel size.

NOTE: Always use a dowel to block the rotor against the body, not against the other rotor.

7. Screw the rotor nuts (Figure 80, item 26) onto the shafts (clockwise) and tighten them to the required torque.



CAUTION: Use a torque wrench to tighten the rotor nuts to the proper torque. Failure to tighten the nuts properly could result in the nuts loosening during operation, causing damage to the pump.

Install Cover

1. Clean the cover o-ring (Figure 80, item 36) and install it in the groove in the cover.
2. Match the large and small dowel pin sizes on the pump body with the dowel pin holes in the cover.
3. Install the cover (Figure 80, item 2) on the pump body.
4. Prior to assembly of the cover nuts, apply an anti-seize compound compatible with the product to the threads of the body studs.
5. Tighten the cover securely using the cover nuts (Figure 80, item 11).



CAUTION: Failure to tighten the cover nuts to the proper torque could cause the body studs to fail prematurely under high pressure.



CAUTION: If a double seal arrangement is used, the seals must be provided with a clean, compatible barrier fluid. Make certain that the flush ports in the pump body are clean and clear.

Reference Tables







Universal Series Wrench Sizes			
Model	Rotor Nut	Body Retaining Cap Screw	Cover Nut
018UL	15/16"	3/16"	5/8"
030UL, 050UL	1-1/4"	3/16"	5/8"
060UL, 130UL	1-5/8"	1/4"	7/8"
220UL	2-1/4"	5/16"	7/8"
320UL	2-3/8"	5/16"	1"

Torque Values				
Model	Locknuts			Locknut Tool
	Gear	Rotor	Cover	
018UL	75 ft·lb 102 N·m	50 ft·lb 68 N·m	7 ft·lb 10 N·m	109281+
030UL, 050UL	100 ft·lb 136 N·m	120 ft·lb 163 N·m	11 ft·lb 15 N·m	109282+
060UL, 130UL	140 ft·lb 190 N·m	250 ft·lb 339 N·m	56 ft·lb 76 N·m	109283+
220UL	230 ft·lb 312 N·m	325 ft·lb 441 N·m	110 ft·lb 149 N·m	--
320UL	320 ft·lb 434 N·m	375 ft·lb 508 N·m	158 ft·lb 214 N·m	--

Arbor or Hydraulic Press Tonnage (approx.)						
Model	Shaft		Front Bearing		Rear Bearing	
	IN	OUT	ON	OFF	ON	OFF
018UL, 030UL, 050UL	0.25	0.50	0.50	1.00	0.50	1.00
060UL, 130UL	0.50	1.00	2.00	5.00	3.00	5.00
220UL	0.50	1.00	5.00	15.00	5.00	15.00
320UL	0.50	1.00	5.00	20.00	5.00	20.00

NOTE: For locking assembly torque values, see Table 7, "UL Locking Assembly Data," on page 38.

Standard WCB O-Ring Selections, Descriptions and Color Codes

<p>Nitrile (Buna-N) (NBR) Compound Color: Black Color Code: Yellow FDA Compliant to 21CFR177.2600 3A Sanitary</p> 	<p>Silicone (Si) Compound Color: Orange Color Code: Black FDA Compliant to 21CFR177.2600 3A Sanitary</p> 
<p>Ethylene Propylene Diene Rubber (EPDM) Compound Color: Black or Purple Color Code: Green FDA Compliant to 21CFR177.2600</p> 	<p>Perfluoroelastomer (FFKM) Compound Color: Black Color Code: None Individually packaged with size and material noted.</p> 
<p>Ethylene Propylene Diene Rubber (Sulfur Free) (EPDM) Compound Color: Black or Purple Color Code: Blue FDA Compliant to 21CFR177.2600</p> 	<p>PTFE Encapsulated Compound Color: Translucent coating over Orange or Black Silicone or FKM core Color Code: None FDA Compliant to 21CFR177.2600</p> 
<p>Fluorocarbon Rubber (FKM) Compound Color: Rust, Brown or Black Color Code: White FDA Compliant to 21CFR177.2600 3A Sanitary</p> 	

Parts Lists

018-UL PD Pumps

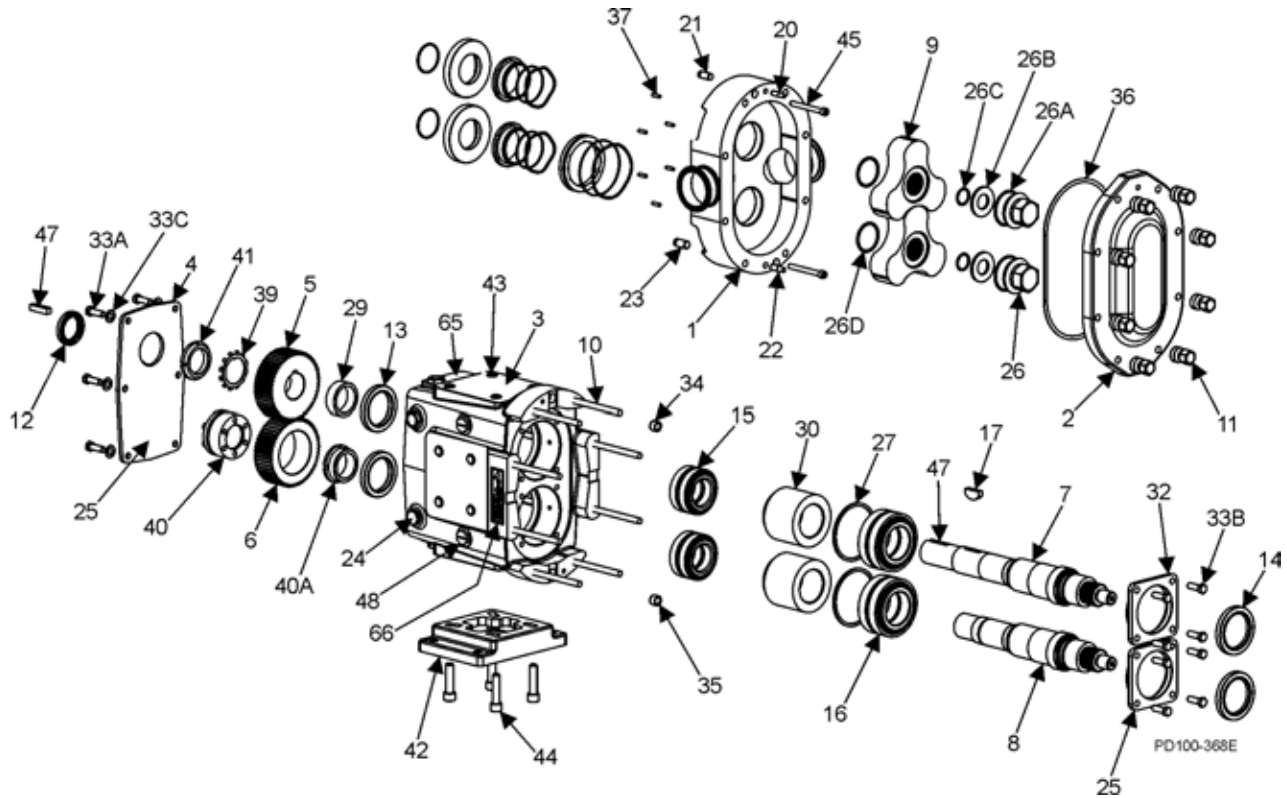

ITEM NO.	DESCRIPTION	QTY. PER PUMP	PART NO.	NOTES
1	Pump Body	1	See Note 1	1
	Pump Body with Flush	1	See Note 1	1
7	Drive Shaft (Obsoletes 103219)	1	122406+	
8	Short Shaft (Obsoletes 103220)	1	122407+	
9	Rotor, 3 Lobe, Alloy 88 (Obsoletes 103202)	2	117494+	2, 22
	Rotor, 3 Lobe, 316SS (Obsoletes 105689)	2	117496+	2, 22
10	Stud	8	101721+	
	Stud, Jacketed Cover	8	107754+	

PL5060-CH1

NOTES:

1. Contact Factory with Serial Number of pump for Part Number.
2. Standard clearances and finishes for Rotor Part Numbers shown. Contact Factory for optional clearances and finishes.
22. Replaced by new rotor profile in 2002. Do **NOT** mix old and new profile rotors.

018-UL PD Pumps

ITEM NO.	DESCRIPTION	QTY. PER PUMP	PART NO.	NOTES
2	Pump Cover	1	103213+	
	Jacketed Cover	1	107665+	
	Pump Cover Vented - Complete Assembly			
	Manual (over 150 PSI)	1	CVR00113	
	Manual (under 150 PSI)	1	CVR00083	
	Pneumatic	1	CVR00084	
	Piston	1	CVR00085	
3	Gear Case, CI	1	102276+	
	Gear Case, SS; Optional	1	101831+	
4	Gear Case Cover, Steel	1	020106000+	
	Gear Case Cover, SS; Optional	1	102280+	
5	Gear, Drive Shaft, Spur (Obsoletes 015007001)	1	107997+	19
6	Gear, Short Shaft, Spur (Obsoletes 103233)	1	107998+	19
11	Hex Nut	8	108369+	
	Wing Nut; Optional	8	105850+	
12	Oil Seal, Gear Case Cover	1	000030016+	
13	Oil Seal, Gear Case Rear	2	000030017+	
14	Grease Seal, Bearing Retainer	2	121679+	
	Bearing Isolator Kit, includes SS Bearing Retainer	1	X06638-1	
15	Bearing, Rear	2	015035000+	
16	Bearing, Front	2	101714+	
17	Key, Gear	1	015037000+	
20	Dowel Pin, Upper Cover Side	1	AD0040000	
21	Dowel Pin, Upper Gear Case Side	1	AD0040R00	
22	Dowel Pin, Lower Cover Side	1	AD0040100	
23	Dowel Pin, Lower Gear Case Side	1	AD0040R10	
24	Oil Plug; Fill, Drain	5	115798+	
25	Silicone Sealant	1	000142301+	
26	Nut, Rotor	2	101804+	
* 26A	O-Ring, Rotor Nut, Buna N	2	N70126	
* 26A	O-Ring, Rotor Nut, EPDM	2	E70126	
* 26A	O-Ring, Rotor Nut, FKM	2	V70126	
26B	Washer, Belleville	2	101691+	
* 26C	O-Ring, Retainer, Buna N	2	N70112	
* 26C	O-Ring, Retainer, EPDM	2	E70112	
* 26C	O-Ring, Retainer, FKM	2	V70112	
* 26D	O-Ring, Rotor Hub, Buna N	2	N70121	
* 26D	O-Ring, Rotor Hub, EPDM	2	E70121	
* 26D	O-Ring, Rotor Hub, FKM	2	V70121	

PL5060-CH2

NOTES:

19. Old and new gears cannot be mixed. Changed from helical to spur gears in 1997.

* **Recommended Spare Parts**

018-UL PD Pumps

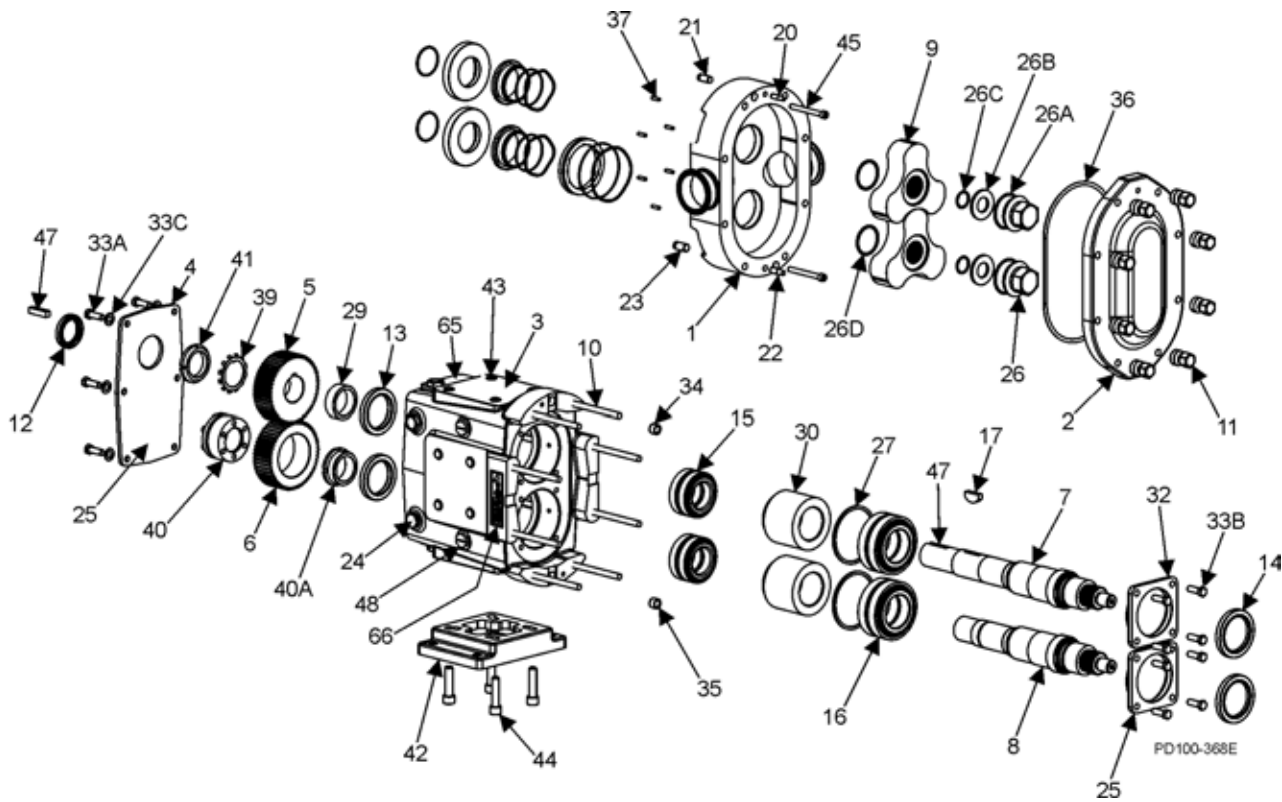

018-UL PD Pumps

ITEM NO.	DESCRIPTION	QTY. PER PUMP	PART NO.	NOTES
27	Shim Kit	2	117889+	
29	Spacer, Gear to Rear Bearing	1	015055000+	
30	Bearing Spacer	2	101814+	
32	Bearing Retainer, Front	2	120332+	
33A, 33B	1/4-20 x .75" HHCS, STD	14	30-287	
	1/4-20 x .75" HHCS, SS	14	30-58	
33C	1/4" Flat Washer	6	43-108	
34	Dowel Bushing, Upper	1	AD0116000	
35	Dowel Bushing, Lower	1	AD0116100	
* * *	O-Ring, Pump Cover, Buna N	1	N70249	
	O-Ring, Pump Cover, EPDM	1	E70249	
	O-Ring, Pump Cover, FKM	1	V70249	
37	Stop Pin, Seal	6	101718+	
39	Lockwasher, Gear	2	STD136005	
40	Locking Assembly	1	103241+	
40A	Locknut, Sleeve	1	108200+	
	Locknut, Sleeve	1	103229+	21
41	Locknut, Gear	2	STD236005	
42	Gear Case Shim, CI	1	020110000+	
	Gear Case Shim, SS; Optional	1	102284+	
	Pump Pedestal, 6.75", Optional	1	014110675+	
43	Plastic Cap Plug	8	000121003+	
44	5/16-18 x 1" SHCS	4	30-343	
	5/16-18 x 1" SHCS, SS; Optional	4	30-525	
45	Body Retaining Screw, 1/4-20 x 2"	2	30-211	
47	Key, Coupling - 3/16 x 3/16 x 1-1/8"	1	000037001+	
48	Cleanout Plug	2	35824+	
61	Name Plate, Sanitary	1	001061002+	
62	#2 x .125" RHDS	4	30-355	
65	Caution Plate	2	121694+	
66	Warning Label	2	33-63	
67	Grease Fitting, 1/8"	4	BD0092000	
68	Plastic Cap, Grease Fitting	4	BD0093000	

PL5060-CH3

NOTES:

21. Sleeve locknut for pump made prior to change in 1997.

* **Recommended Spare Parts**

030-UL, 034-UL, 050-UL, 054-UL PD Pumps

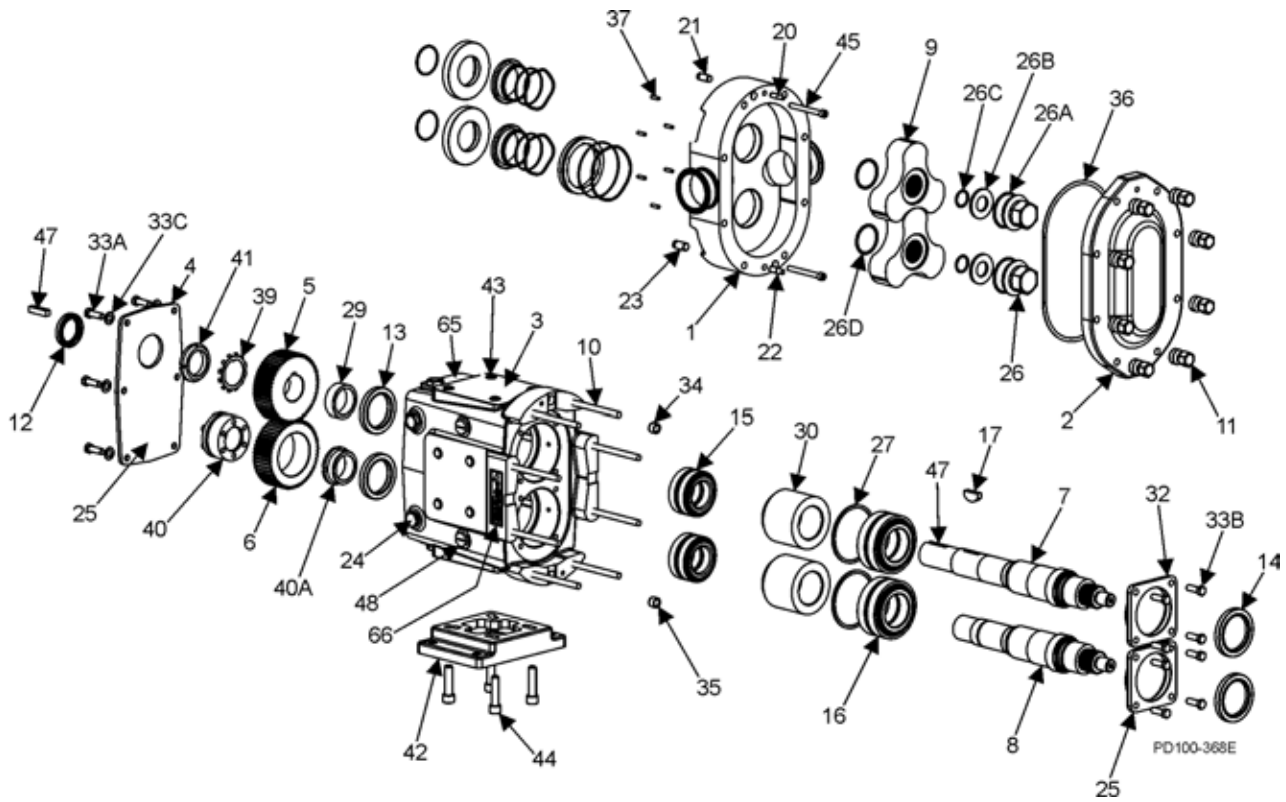

030-UL, 034-UL, 050-UL, 054-UL PD Pumps

ITEM NO.	DESCRIPTION	QTY. PER PUMP	PART NO.	NOTES
1	030-UL Pump Body	1	See Note 1	1
	030-UL Pump Body with Flush	1	See Note 1	1
	034-UL Rectangular Flange Inlet Body	1	See Note 1	1
	034-UL Rectangular Flange Inlet Body with Flush	1	See Note 1	1
	050-UL Pump Body	1	See Note 1	1
	050-UL Pump Body with Flush	1	See Note 1	1
	054-UL Rectangular Flange Inlet Body	1	See Note 1	1
	054-UL Rectangular Flange Inlet Body with Flush	1	See Note 1	1
7	030-034-UL Drive Shaft (Obsoletes 108419)	1	122491+	
	050-054-UL Drive Shaft	1	122494+	
8	030-034-UL Short Shaft (Obsoletes 108420)	1	122492+	
	050-054-UL Short Shaft	1	122495+	
9	030-034-UL Rotor, 3 Lobe, Alloy 88 (Obsoletes 103203)	2	122511+	2, 22
	030-034-UL Rotor, 3 Lobe, 316SS (Obsoletes 104344)	2	122513+	2, 22
	050-054-UL Rotor, 3 Lobe, Alloy 88 (Obsoletes 109861)	2	122515+	2, 22
	050-054-UL Rotor, 3 Lobe, 316SS (Obsoletes 109863)	2	122831+	2, 22
10A	030-UL Stud	8	108842+	
10B	030-UL Stud, Jacketed Cover	8	108845+	
10C	034-UL Stud	6	108842+	
	034-UL Stud	2	35555+	
10D	034-UL Stud, Jacketed Cover	6	108845+	
	034-UL Stud, Jacketed Cover	2	35549+	
10E	050-UL Stud	8	109865+	
10F	050-UL Stud, Jacketed Cover	8	TBD	
10G	054-UL Stud	6	109865+	
	054-UL Stud	2	35555+	
10H	054-UL Stud, Jacketed Cover	6	TBD	
	054-UL Stud, Jacketed Cover	2	35549+	

PL5060-CH6

NOTES:

- Contact Factory with Serial Number of pump for Part Number.
- Standard clearances and finishes for Rotor Part Numbers shown. Contact Factory for optional clearances and finishes.
- Replaced by new rotor profile in 2002. Do **NOT** mix old and new profile rotors.

030-UL, 050-UL PD Pumps

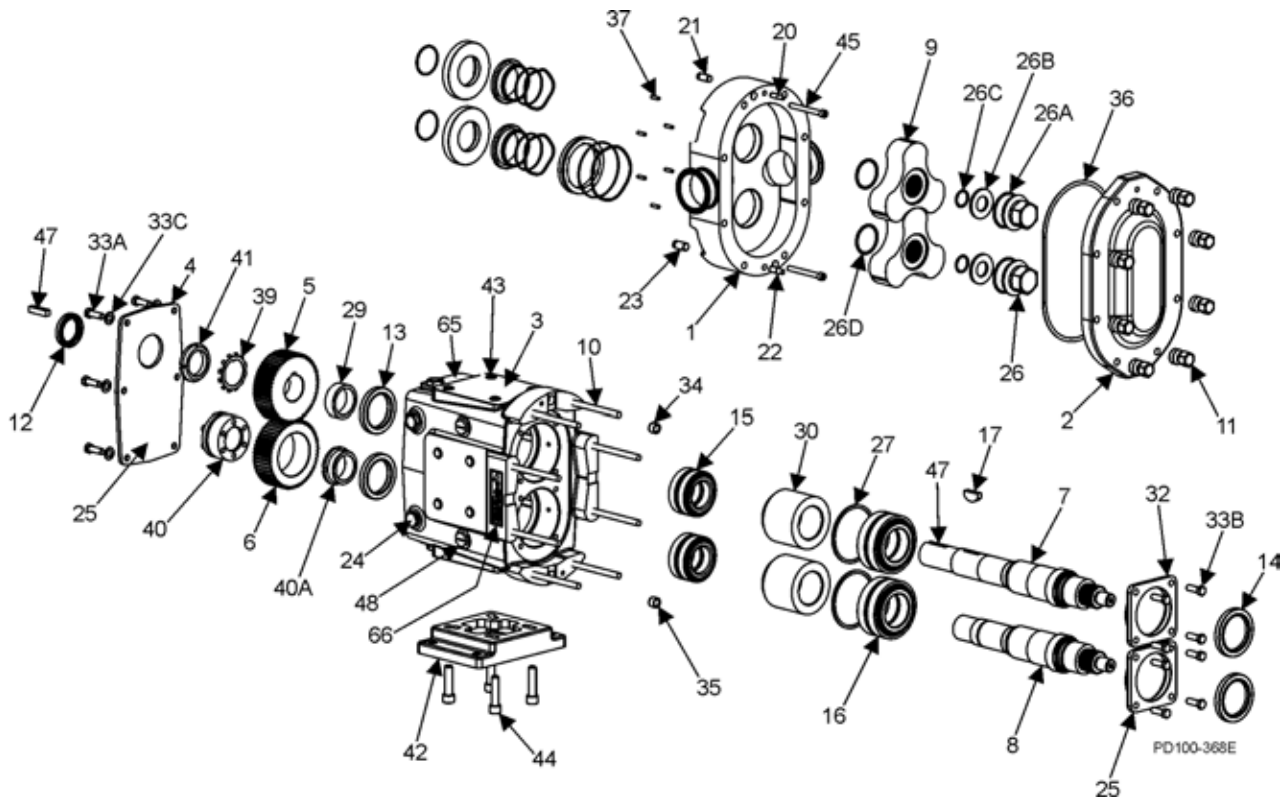

030-UL, 034-UL, 050-UL, 054-UL PD Pumps

ITEM NO.	DESCRIPTION	QTY. PER PUMP	PART NO.	NOTES
2	Pump Cover	1	103214+	
	Jacketed Cover	1	107667+	
	Pump Cover Vented - Complete Assembly			
	Manual (over 150 PSI)	1	CVR00018	
	Manual (under 150 PSI)	1	CVR00044	
	Pneumatic	1	CVR00086	
	Piston	1	CVR00087	
3	Gear Case, CI	1	102277+	
	Gear Case, SS; Optional	1	101833+	
4	Gear Case Cover, Steel	1	040106000+	
	Gear Case Cover, SS; Optional	1	102281+	
5	Gear, Drive Shaft, Spur (Replaces 030007001)	1	107999+	19
6	Gear, Short Shaft, Spur (Replaces 103234)	1	108000+	19
11	Hex Nut	8	108370+	
	Wing Nut; Optional	8	105851+	
12	Oil Seal, Gear Case Cover	1	000030013+	
13	Oil Seal, Gear Case Rear	2	000030014+	
14	Grease Seal, Bearing Retainer	2	101717+	
	Bearing Isolator Kit, includes SS Bearing Retainer	1	X06639-1	
15	Bearing, Rear	2	030035000+	
16	Bearing, Front	2	101715+	
17	Key, Gear	2	BD0037000	
20	Dowel Pin, Upper Cover Side	1	BD0040000	
21	Dowel Pin, Upper Gear Case Side	1	BD0040200	
22	Dowel Pin, Lower Cover Side	1	BD0040100	
23	Dowel Pin, Lower Gear Case Side	1	BD0040300	
24	Hex Capscrew; Fill, Drain, Level	6	000046003+	
25	Silicone Sealant	1	000142301+	
26	Nut, Rotor	2	101805+	
* 26A	O-Ring, Rotor Nut, Buna N	2	N70130	
* 26A	O-Ring, Rotor Nut, EPDM	2	E70130	
* 26A	O-Ring, Rotor Nut, FKM	2	V70130	
26B	Washer, Belleville	2	101692+	
* 26C	O-Ring, Retainer, Buna N	2	N70115	
* 26C	O-Ring, Retainer, EPDM	2	E70115	
* 26C	O-Ring, Retainer, FKM	2	V70115	
* 26D	O-Ring, Rotor Hub, Buna N	2	N70127	
* 26D	O-Ring, Rotor Hub, EPDM	2	E70127	
* 26D	O-Ring, Rotor Hub, FKM	2	V70127	

PL5060-CH7

NOTES:

19. Old and new gears can not be mixed. Changed from helical to spur gears in 1997.

* Recommended Spare Parts

030-UL, 034-UL, 050-UL, 054-UL PD Pumps

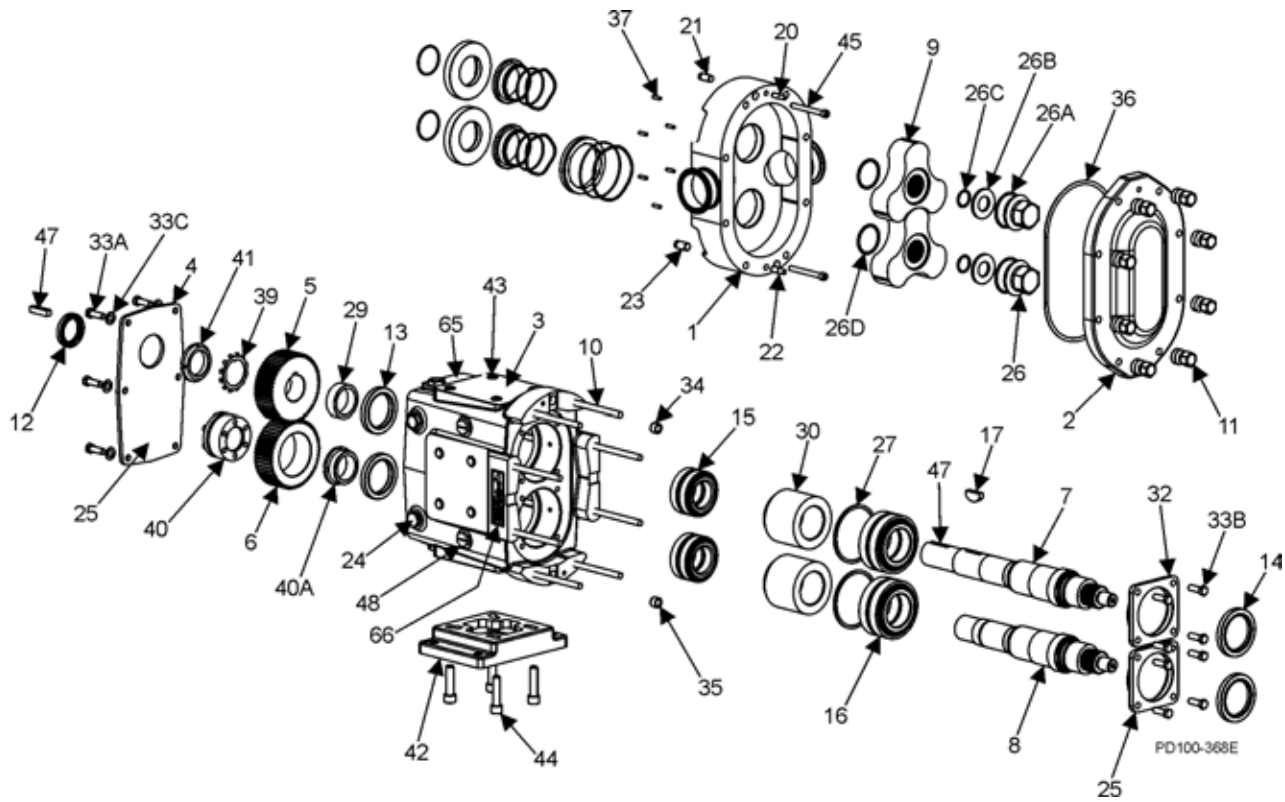

030-UL, 034-UL, 050-UL, 054-UL PD Pumps

ITEM NO.	DESCRIPTION	QTY. PER PUMP	PART NO.	NOTES
27	Shim Kit	2	117890+	
29	Spacer, Gear to Rear Bearing	1	030055000+	
30	Bearing Spacer	2	101815+	
32	Bearing Retainer, Front	2	101811+	
33A	5/16-18 x 3/4" HHCS, STD	6	30-283	
	5/16-18 x 3/4" SHCS, SS	6	30-29	
33B	5/16-18 x 3/4" BSHCS, STD	8	30-296	
	5/16-18 x 3/4" SHCS, SS	8	30-29	
33C	5/16" Flat Washer	6	43-194	
34	Dowel Bushing, Upper	1	BD0116000	
35	Dowel Bushing, Lower	1	BD0116100	
* 36	O-Ring, Pump Cover, Buna N	1	N70259	
	O-Ring, Pump Cover, EPDM	1	E70259	
	O-Ring, Pump Cover, FKM	1	V70259	
* 36B	034-UL O-Ring, Rectangular Flange	1	N70357	
	054-UL O-Ring, Rectangular Flange	1	N70259	
37	Stop Pin, Seal	6	101719+	
39	Lockwasher, Gear	2	CD0036W00	
40	Locking Assembly (Replaces 103242)	1	108784+	
40A	Locknut, Sleeve	1	108201+	
	Locknut, Sleeve	1	103230+	21
41	Locknut, Gear	2	CD0036N00	
42	Gear Case Shim, CI	1	040110000+	
	Gear Case Shim, SS; Optional	1	102285+	
	Pump Pedestal, 6.25", Optional	1	BD0110SM0	
43	Plastic Cap Plug, 3/8"	8	000121002+	
44	3/8-16 x 1" SHCS, STD	4	30-344	
	3/8-16 x 1" SHCS, SS; Optional	4	30-189	
45	030-034-UL Body Retaining Screw, 1/4-20 x	2	30-211	
	050-054-UL Body Retaining Screw, 1/4-20 x	2	30-613	
47	Key, Coupling - 1/4 x 1/4 x 1-3/4"	1	000037002+	
48	Cleanout Plug	2	41013+	
61	Name Plate, Sanitary	1	001061002+	
62	#2 x .125" RHDS	4	30-355	
65	Caution Plate	2	33-62	
66	Warning Label	2	33-63	
67	030-050-UL Grease Fitting, 1/8"	4	BD0092000	
	034-054-UL Grease Fitting, 1/8"	4	BD0092100	
68	Plastic Cap, Grease Fitting	4	BD0093000	

PL5060-CH8

NOTES:

21. Sleeve locknut required for pump made prior to change in 1997.

* **Recommended Spare Parts**

060-UL, 130-UL, 134-UL PD Pumps

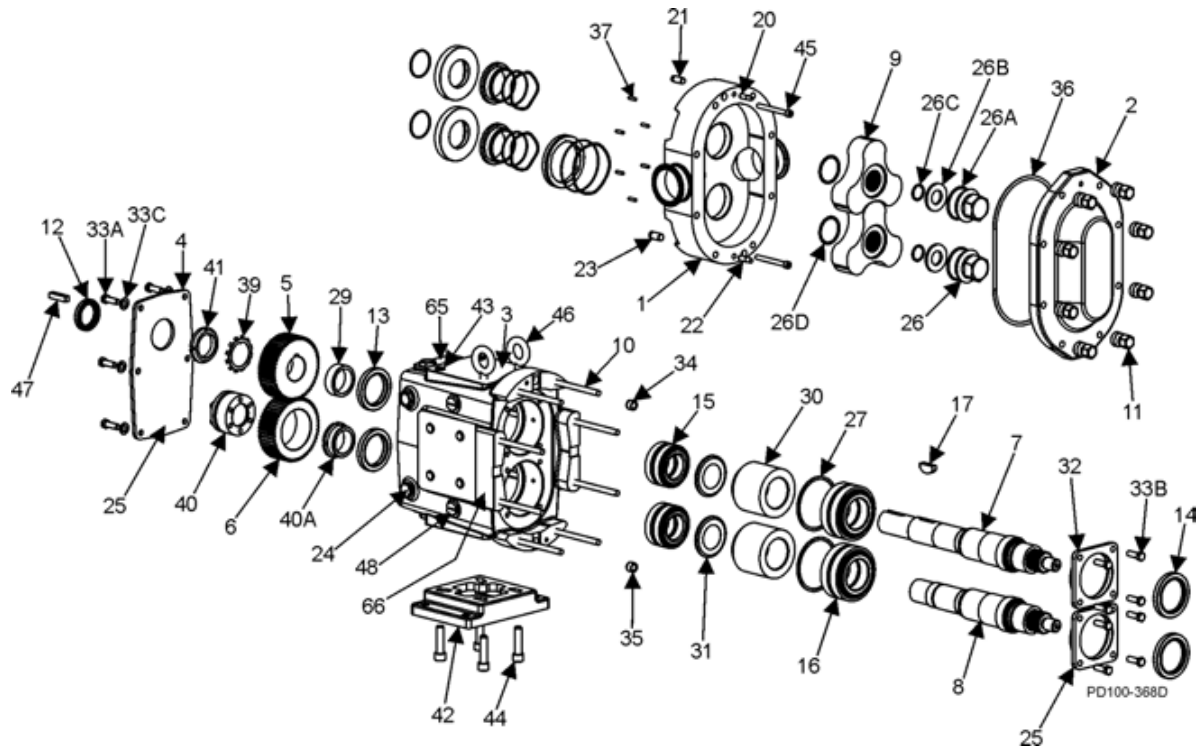

060-UL, 130-UL, 134-UL PD Pumps

ITEM NO.	DESCRIPTION	QTY. PER PUMP	PART NO.	NOTES
1	060-UL Pump Body	1	See Note 1	1
	060-UL Pump Body with Flush	1	See Note 1	1
	130-UL Pump Body	1	See Note 1	1
	130-UL Pump Body with Flush	1	See Note 1	1
	134-UL Rectangular Flange Inlet Body	1	See Note 1	1
	134-UL Rect. Flange Inlet Body with Flush	1	See Note 1	1
7	060-UL Drive Shaft (Obsoletes 108421)	1	122498+	
	130-134-UL Drive Shaft (Obsoletes 108423)	1	122501+	
8	060-UL Short Shaft (Obsoletes 108422)	1	122499+	
	130-134-UL Short Shaft (Obsoletes 108424)	1	122502+	
9	060-UL Rotor, 3 Lobe, Alloy 88 (Obsoletes 103204)	2	117506+	2, 22
	060-UL Rotor, 3 Lobe, 316SS (Obsoletes 104346)	2	117508+	2, 22
	130-134-UL Rotor, 3 Lobe, Alloy 88 (Obsoletes 103205)	2	117510+	2, 22
	130-134-UL Rotor, 3 Lobe, 316SS (Obsoletes 104348)	2	117512+	2, 22
10A	060-UL Stud	8	108843+	
10B	060-UL Stud, Jacketed Cover	8	108846+	
10C	130-UL Stud	8	101722+	
10D	130-UL Stud, Jacketed Cover	8	130011001+	
10E	134-UL Stud	6	130011000+	
	134-UL Stud	2	0C1050000	
10F	134-UL Stud, Jacketed Cover	6	130011001+	
	134-UL Stud, Jacketed Cover	2	35556+	

PL5060-CH11

NOTES:

1. Contact Factory with Serial Number of pump for Part Number.
2. Standard clearances and finishes for Rotor Part Numbers shown. Contact Factory for optional clearances and finishes.
22. Replaced by new rotor profile in 2002. Do **NOT** mix old and new profile rotors.

060-UL, 130-UL, 134-UL PD Pumps

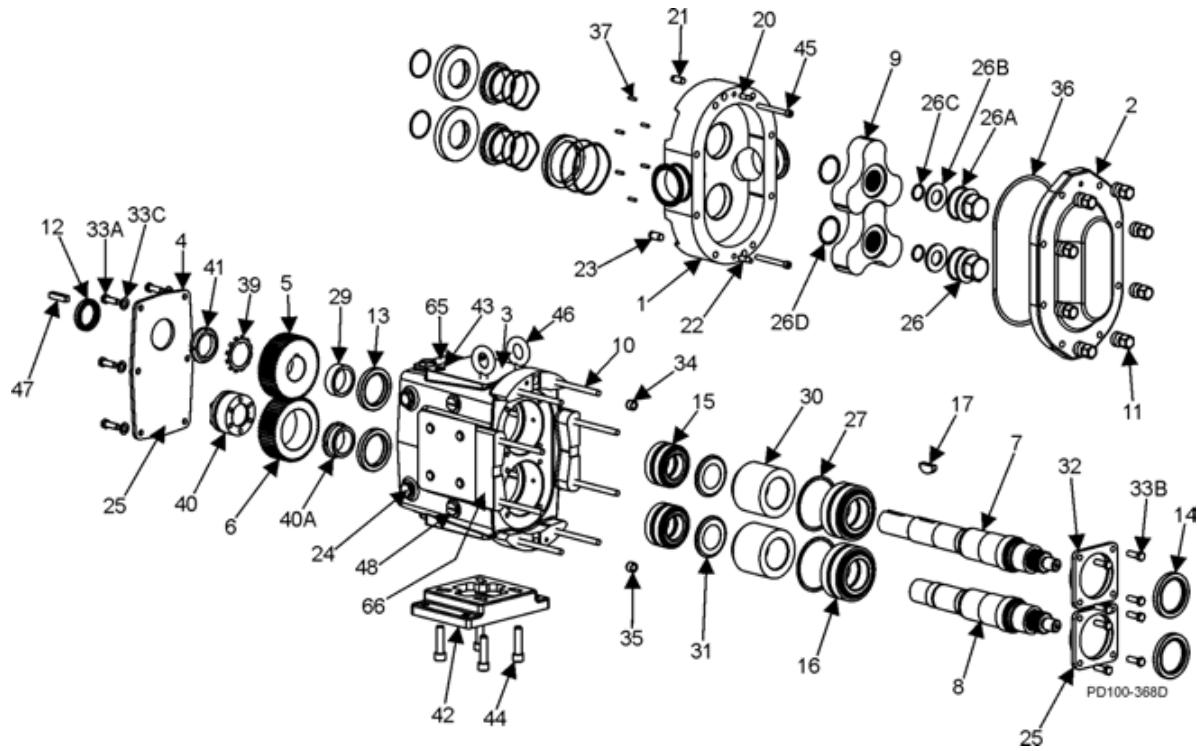

060-UL, 130-UL, 134-UL PD Pumps

ITEM NO.	DESCRIPTION	QTY. PER PUMP	PART NO.	NOTES
2	Pump Cover	1	103215+	
	Jacketed Cover	1	107669+	
	Pump Cover Vented - Complete Assembly			
	Manual (over 150 PSI)	1	CVR00036	
	Manual (under 150 PSI)	1	CVR00088	
	Pneumatic	1	CVR 00089	
	Piston	1	CVR00090	
3	Gear Case, CI	1	070005000+	
	Gear Case, SS; Optional	1	101834+	
4	Gear Case Cover, Steel	1	070106000+	
	Gear Case Cover, SS; Optional	1	102282+	
5	Gear, Drive Shaft, Spur (Replaces 060007001)	1	107404+	19
6	Gear, Short Shaft, Spur (Replaces 103235)	1	107405+	19
11	Hex Nut	8	108371+	
	Wing Nut, Optional	8	105852+	
12	Oil Seal, Gear Case Cover	1	000030012+	
13	Oil Seal, Gear Case Rear	2	000030011+	
14	Grease Seal, Bearing Retainer	2	101829+	
	Bearing Isolator Kit, Includes STD Bearing Retainer	1	X06614-1	
	Bearing Isolator Kit, Includes SS Bearing Retainer	1	X06614-2	
15	Bearing, Rear	2	107186+	
16	Bearing, Front	2	060036000+	
17	Key, Gear	2	060037000+	
20	Dowel Pin, Upper Cover Side	1	CD0040000	
21	Dowel Pin, Upper Gear Case Side	1	CD0040R00	
22	Dowel Pin, Lower Cover Side	1	CD0040100	
23	Dowel Pin, Lower Gear Case Side	1	CD0040R10	
24	Plug w/ washer, 3/4-16	6	000046004+	40
	Oil Plug, M20 x 1.5"	5	115798+	41
	Oil Level Indicator, M20 x 1.5"	1	115799+	41
25	Silicone Sealant	1	000142301+	
26	Nut, Rotor	2	101806+	
* 26A	O-Ring, Rotor Nut, Buna N	2	N70227	
	O-Ring, Rotor Nut, EPDM	2	E70227	
	O-Ring, Rotor Nut, FKM	2	V70227	
26B	Belleville Washer	2	101693+	
* 26C	O-Ring, Retainer, Buna N	2	N70119	
	O-Ring, Retainer, EPDM	2	E70119	
	O-Ring, Retainer, FKM	2	V70119	
* 26D	O-Ring, Rotor Hub, Buna N	2	N70224	
	O-Ring, Rotor Hub, EPDM	2	E70224	
	O-Ring, Rotor Hub, FKM	2	V70224	

NOTES:

PL5060-CH12

19. Old and new gears can not be mixed. Changed from helical to spur gears in 1997.

40. Pumps shipped prior to 5/15/03

41. Pumps shipped after 5/15/03

* **Recommended Spare Parts**

060-UL, 130-UL, 134-UL PD Pumps

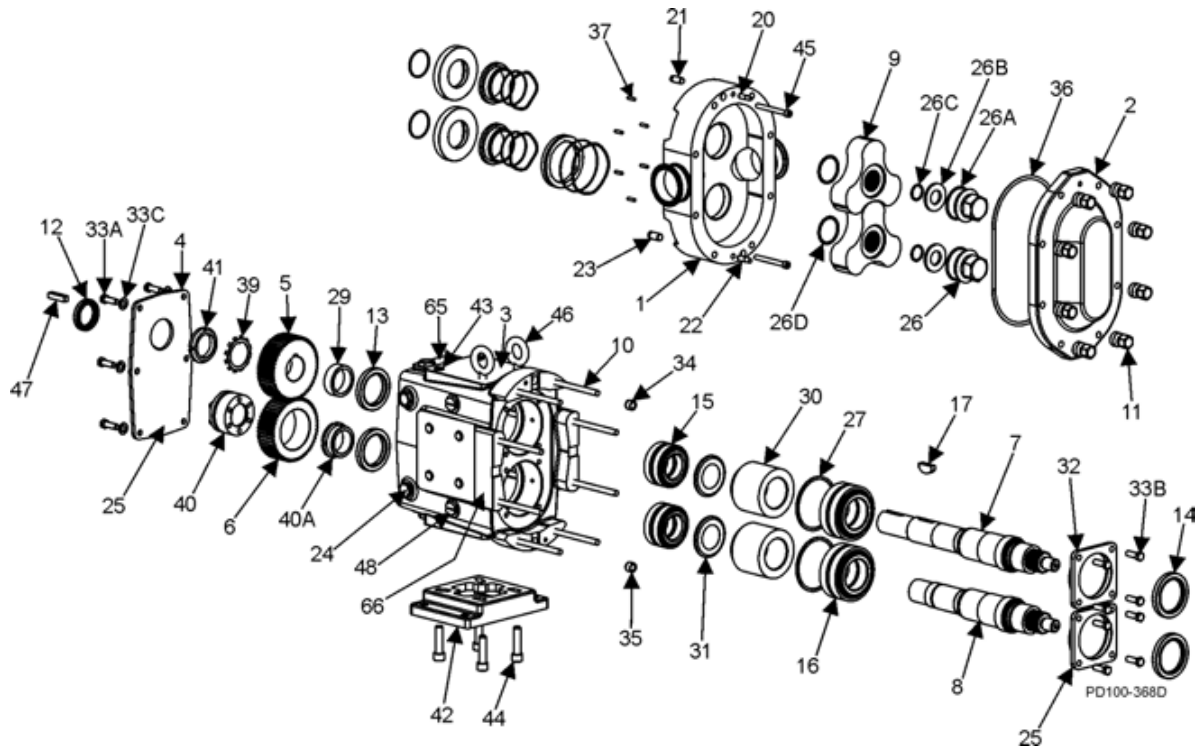

060-UL, 130-UL, 134-UL PD Pumps

ITEM NO.	DESCRIPTION	QTY. PER PUMP	PART NO.	NOTES
27	Shim Kit	2	117891+	
29	Spacer, Gear to Rear Bearing	2	107187+	
30	Bearing Spacer	2	060055003+	
31	Grease Retainer, Rear Bearing	2	STD091002	
32	Bearing Retainer, Front, STD	2	123531+	
	Bearing Retainer, Front, SS	2	121828+	
33A	3/8-16 x 3/4" HHCS, STD Gear Case Cover	6	30-314	
	3/8-16 x 3/4" HHCS, SS Gear Case Cover	6	30-50	
33B	3/8-16 x 1-1/4" HHCS, STD Bearing Retainer	8	30-351	
	3/8-16 x 1-1/4" HHCS, SS Bearing Retainer	8	30-60	
33C	3/8" Flat Washer, Gear Case Cover	6	43-189	
34	Dowel Bushing, Upper	1	CD0116000	
35	Dowel Bushing, Lower	1	CD0116100	
* * * * *	O-Ring, Pump Cover, Buna N	1	N70373	
	O-Ring, Pump Cover, EPDM	1	E70373	
	O-Ring, Pump Cover, FKM	1	V70373	
	O-Ring, Pump Cover, Silicone	1	S75373	
36B	134-UL O-Ring, Rectangular Flange	1	N70369	
37	Stop Pin, Seal	6	101720+	
39	Lockwasher, Gear	2	STD136009	
40	Locking Assembly (Replaces 103243)	1	108785+	
40A	Locknut, Sleeve	1	108202+	
	Locknut, Sleeve	1	103231+	21
41	Locknut, Gear	2	STD236009	
42	Gear Case Shim, CI	1	070110000+	
	Gear Case Shim, SS; Optional	1	102286+	
	Pump Pedestal, 5.5", Optional	1	CD0110SM5	
	Pump Pedestal, 10", Optional	1	CD0110SM1	
43	Plastic Cap Plug	6	000121001+	
44	1/2-13 x 1-1/4" SHCS	4	30-275	
	1/2-13 x 1-1/4" SS SHCS	4	30-503	
45	060-UL Body Retaining Screws, 5/16-8 x 3"	2	30-319	
	130-134-UL Body Retaining Screws, 5/16-8 x 4"	2	30-423	
46	Eye Bolt, 1/2 -13	2	30-360	
47	Key, Coupling - 3/8 x 3/8 x 1-5/8"	1	000037003+	
48	Cleanout Plug	2	41013+	
61	Name Plate, Sanitary	1	001061002+	
62	#2 x .125" RHDS	4	30-355	
65	Caution Plate	2	121694+	
66	Warning Label	2	33-60	
67	060-130-UL Grease Fitting, 1/8"	4	BD0092000	
	134-UL Grease Fitting, 1/8"	4	BD0092100	
68	Plastic Cap, Grease Fitting	4	BD0093000	

PL5060-CH13

NOTES:

21. If new sleeve locknut required for pump made prior to change in 1997, new P/N short shafts, and new P/N gears are required.

* Recommended Spare Parts

220-UL PD Pumps

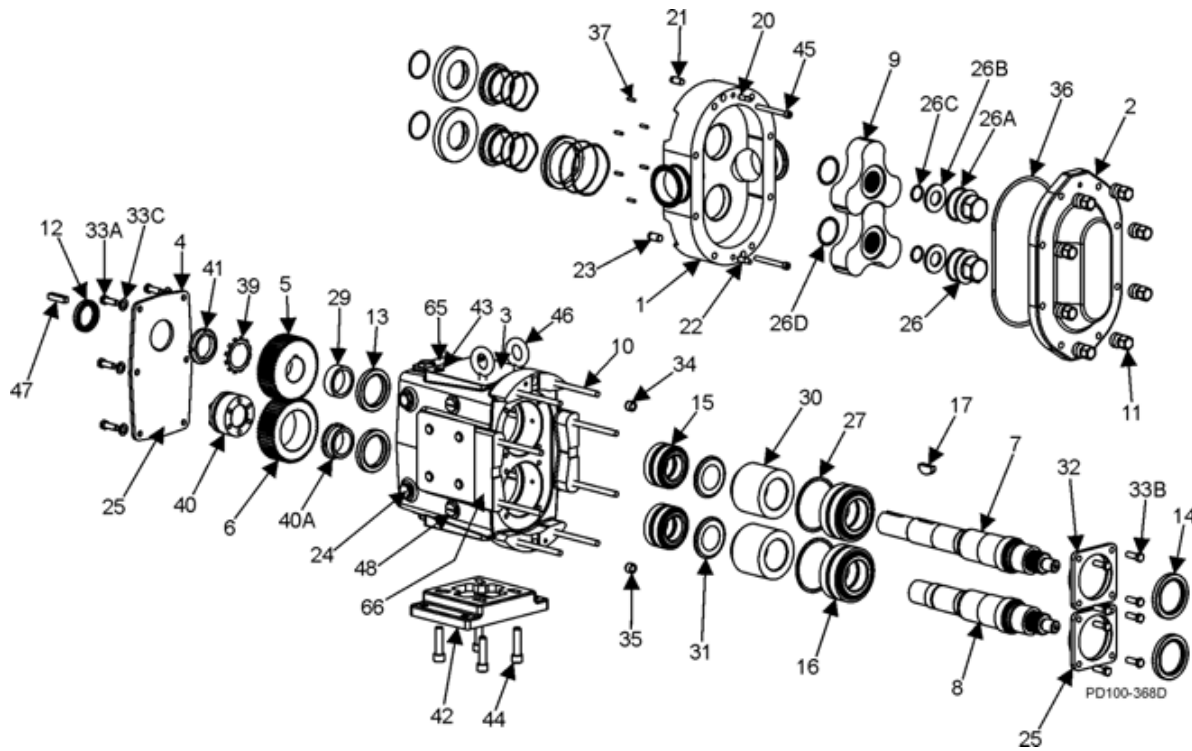

ITEM NO.	DESCRIPTION	QTY. PER PUMP	PART NO.	NOTES
1	Pump Body	1	See Note 1	1
	Pump Body with Flush	1	See Note 1	1
7	Drive Shaft (Replaces 108425)	1	122504+	
8	Short Shaft (Replaces 108426)	1	122505+	
9	Rotor, 3 Lobe, Alloy 88 (Obsoletes 103206)	2	123841+	2, 22
	Rotor, 3 Lobe, 316SS (Obsoletes 104350)	2	123843+	2, 22
10	Stud	8	108844+	
	Stud, Jacketed Cover	8	108847+	

PL5060-CH16

NOTES:

1. Contact Factory with Serial Number of pump for Part Number.
2. Standard clearances and finishes for Rotor Part Numbers shown. Contact Factory for optional clearances and finishes.
22. Replaced by new rotor profile in 2002. Do **NOT** mix old and new profile rotors.

220-UL PD Pumps

ITEM NO.	DESCRIPTION	QTY. PER PUMP	PART NO.	NOTES
2	Pump Cover	1	103216+	
	Jacketed Cover	1	107671+	
	Pump Cover Vented - Complete Assembly			
	Manual (over 150 PSI)	1	CVR00114	
	Manual (under 150 PSI)	1	CVR00064	
3	Piston	1	CVR00091	
	Gear Case, CI	1	230005000+	
4	Gear Case, SS; Optional	1	101836+	
	Gear Case Cover, Steel	1	230106000+	
5	Gear Case Cover, SS; Optional	1	102283+	
	Gear, Drive Shaft, Spur (Replaces 200 007 001)	1	110932+	19
6	Gear, Short Shaft, Spur (Replaces 103236)	1	112105+	19
11	Hex Nut	8	108372+	
	Wing Nut, Optional	8	105853+	
12	Oil Seal, Gear Case Cover	1	STD030006	
13	Oil Seal, Gear Case Rear	2	STD119002	
14	Grease Seal, Bearing Retainer	2	STD030002	
	Bearing Isolator Kit, Includes STD Bearing Retainer	1	X06634-1	
	Bearing Isolator Kit, Includes SS Bearing Retainer	1	X06634-2	
15	Bearing, Rear	2	200035000+	
16	Bearing, Front	2	200036000+	
17	Key, Gear	2	200037000+	
20	Dowel Pin, Upper Cover Side	1	GD0040000	
21	Dowel Pin, Upper Gear Case Side	1	CD0040R00	
22	Dowel Pin, Lower Cover Side	1	GD0040100	
23	Dowel Pin, Lower Gear Case Side	1	CD0040R10	
24	Plug w/ washer, 3/4-16	6	000046004+	40
	Oil Plug, M20 x 1.5"	5	115798+	41
	Oil Level Indicator, M20 x 1.5"	1	115799+	41
25	Silicone Sealant	1	000142301+	
26	Nut, Rotor	2	101807+	
* 26A	O-Ring, Rotor Nut, Buna N	2	N70235	
* 26A	O-Ring, Rotor Nut, EPDM	2	E70235	
* 26A	O-Ring, Rotor Nut, FKM	2	V70235	
26B	Belleville Washer	2	101694+	
* 26C	O-Ring, Retainer, Buna N	2	N70122	
* 26C	O-Ring, Retainer, EPDM	2	E70122	
* 26C	O-Ring, Retainer, FKM	2	V70122	
* 26D	O-Ring, Rotor Hub, Buna N	2	N70230	
* 26D	O-Ring, Rotor Hub, EPDM	2	E70230	
* 26D	O-Ring, Rotor Hub, FKM	2	V70230	

NOTES:

PL5060-CH17

19. Old and new gears can not be mixed. Changed from helical to spur gears in 1997.

40. Pumps shipped prior to 5/15/03

41. Pumps shipped after 5/15/03

* **Recommended Spare Parts**

220-UL PD Pumps

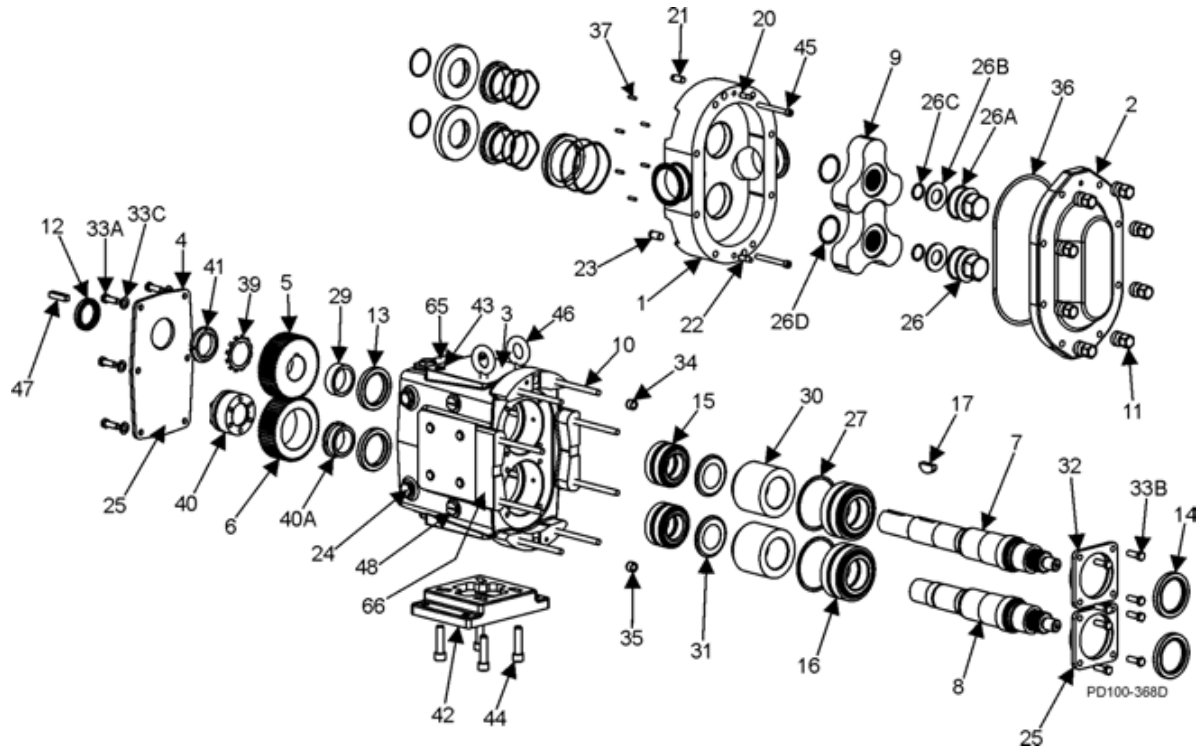

220-UL PD Pumps

ITEM NO.	DESCRIPTION	QTY. PER PUMP	PART NO.	NOTES
27	Shim Kit	2	117892+	
29	Spacer, Gear to Rear Bearing	2	40878+	
30	Bearing Spacer	2	40752+	
32	Bearing Retainer, Front, STD	2	220080000+	
	Bearing Retainer, Front, SS	2	101813+	
33A	3/8-16 x 3/4" HHCS, STD Gear Case Cover	8	30-314	
	3/8-16 x 3/4" HHCS, SS Gear Case Cover	8	30-50	
33B	3/8-16 x 1-1/4" HHCS, STD Bearing Retainer	8	30-351	
	3/8-16 x 1-1/4" HHCS, SS Bearing Retainer	8	30-60	
33C	3/8" Flat Washer, Gear Case Cover	8	43-108	
34	Dowel Bushing, Upper	1	CD0116000	
35	Dowel Bushing, Lower	1	CD0116100	
* * * *	O-Ring, Pump Cover, Buna N	1	N70381	
	O-Ring, Pump Cover, EPDM	1	E70381	
	O-Ring, Pump Cover, FKM	1	V70381	
	O-Ring, Pump Cover, Silicone	1	S75381	
37	Stop Pin, Seal	6	101720+	
39	Lockwasher, Gear	2	STD136011	
40	Locking Assembly (Replaces 103244)	1	108786+	
40A	Locknut, Sleeve	1	108203+	
	Locknut, Sleeve	1	103232+	21
41	Locknut, Gear	2	STD236011	
42	Gear Case Shim, Cl	1	230110000+	
	Gear Case Shim, SS, Optional	1	102287+	
	Pump Pedestal, 9", Optional	1	GD0110SM9	
	Pump Pedestal, 13", Optional	1	GD0110SM1	
43	Plastic Cap Plug	6	000121001+	
44	1/2-13 x 2" SHCS	4	30-111	
	1/2-13 x 2" SS SHCS	4	30-44	
45	Body Retaining Screws, 3/8-16 x 4-1/2"	2	30-499	
46	Eye Bolt, 1/2 -13	2	30-360	
47	Key, Coupling - 1/2 x 1/2 x 1-7/8"	1	000037004+	
48	Cleanout Plug	2	41013+	
61	Name Plate, Sanitary	1	001061002+	
62	#2 x .125" RHDS	4	30-355	
65	Caution Plate	2	33-62	
66	Warning Label	2	33-60	
67	Grease Fitting, 1/8"	4	BD0092000	
68	Plastic Cap, Grease Fitting	4	BD0093000	

PL5060-CH18

NOTES:

21. Sleeve locknut required for pump made prior to change in 1997.

* **Recommended Spare Parts**

320-UL PD Pumps

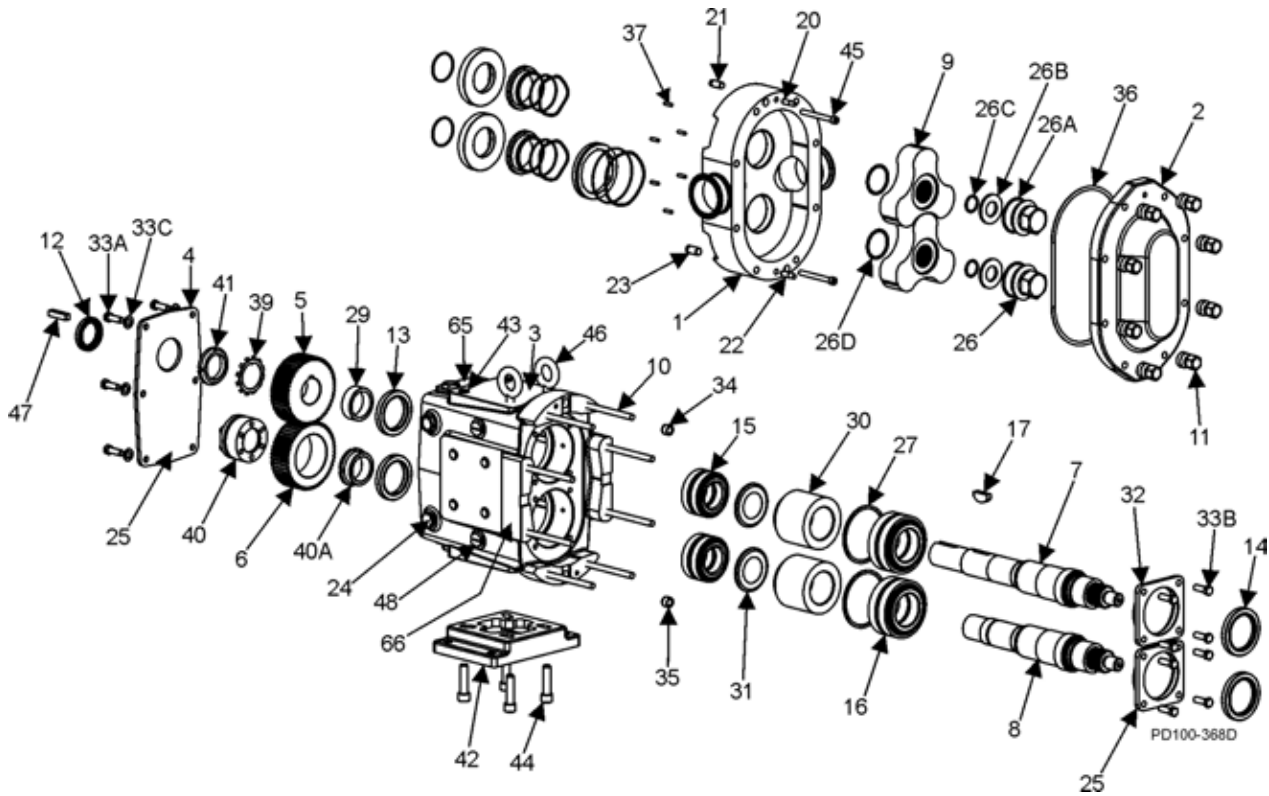

ITEM NO.	DESCRIPTION	QTY. PER PUMP	PART NO.	NOTES
1	Pump Body	1	See Note 1	1
	Pump Body with Flush	1	See Note 1	1
7	Drive Shaft (Obsoletes 108427)	1	123847+	
8	Short Shaft (Obsoletes 108428)	1	123848+	
9	Rotor, 3 Lobe, Alloy 88 (Obsoletes 105496)	2	117518+	2, 22
	Rotor, 3 Lobe, 316SS (Obsoletes 105498)	2	117520+	2, 22
10	Stud, Long	4	111291+	
	Stud, Long, Jacketed Cover	4	111291+	
10A	Stud, Short	4	111292+	
	Stud, Short, Jacketed Cover	4	111292+	

PL5060-CH21

NOTES:

1. Contact Factory with Serial Number of pump for Part Number.
2. Standard clearances and finishes for Rotor Part Numbers shown. Contact Factory for optional clearances and finishes.
22. Replaced by new rotor profile in 2002. Do NOT mix old and new profile rotors.

320-UL PD Pumps

ITEM NO.	DESCRIPTION	QTY. PER PUMP	PART NO.	NOTES
2	Pump Cover	1	105425+	
3	Gear Case, CI	1	105478+	
4	Gear Case Cover, Steel	1	40669+	
5	Gear, Drive Shaft, Spur	1	102470+	
6	Gear, Short Shaft, Spur	1	102471+	
11	Hex Nut	8	108373+	
	Wing Nut, Optional	8	110858+	
12	Oil Seal, Gear Case Cover	1	STD030004	
13	Oil Seal, Gear Case Rear	2	102475+	
14	Grease Seal, Bearing Retainer	2	121681+	
	Bearing Isolator Kit, Incl. STD Bearing Retainer	1	X06634-3	
15	Bearing, Rear	2	OH1036000	
16	Bearing, Front	2	OH1036003	
17	Key, Gear	2	OH1037000	
20	Dowel Pins, Cover Side	2	OH1040000	
21	Dowel Pins, Gear Case Side	2	105871+	
24	Plug w/ washer, 3/4-16	6	000046004+	40
	Oil Plug, M20 x 1.5"	5	115798+	41
	Oil Level Indicator, M20 x 1.5"	1	115799+	41
25	Silicone Sealant	1	000142301+	
26	Nut, Rotor	2	105409+	
* 26A	O-Ring, Rotor Nut, Buna N	2	N70237	
	O-Ring, Rotor Nut, EPDM	2	E70237	
	O-Ring, Rotor Nut, FKM	2	V70237	
	O-Ring, Rotor Nut, Silicone	2	S75237	
26B	Washer, Belleville	2	105411+	
* 26C	O-Ring, Retainer, Buna N	2	N70125	
	O-Ring, Retainer, EPDM	2	E70125	
	O-Ring, Retainer, FKM	2	V70125	
	O-Ring, Retainer, Silicone	2	S75125	
* 26D	O-Ring, Rotor Hub, Buna N	2	N70232	
	O-Ring, Rotor Hub, EPDM	2	E70232	
	O-Ring, Rotor Hub, FKM	2	V70232	
	O-Ring, Rotor Hub, Silicone	2	S75232	
27	Shim Kit	2	117893+	
28	Shim Plate	2	105426+	
28A	Shims, Body, 0.002	AR	105866+	
	Shims, Body, 0.003	AR	105867+	
	Shims, Body, 0.005	AR	105868+	
	Shims, Body, 0.010	AR	105869+	
	Shims, Body, 0.020	AR	105870+	
28D	5/16-18 x 1" FHSCS	4	30-612	
29	Spacer, Gear to Rear Bearing	2	102474+	
30	Bearing Spacer	2	102472+	
30A	Spacer Seal	2	102473+	
31	Retainer, Grease	2	STD091000	

NOTES:

PL5060-CH22

40. Pumps shipped prior to 5/15/03

41. Pumps shipped after 5/15/03

* **Recommended Spare Parts**

320-UL PD Pumps

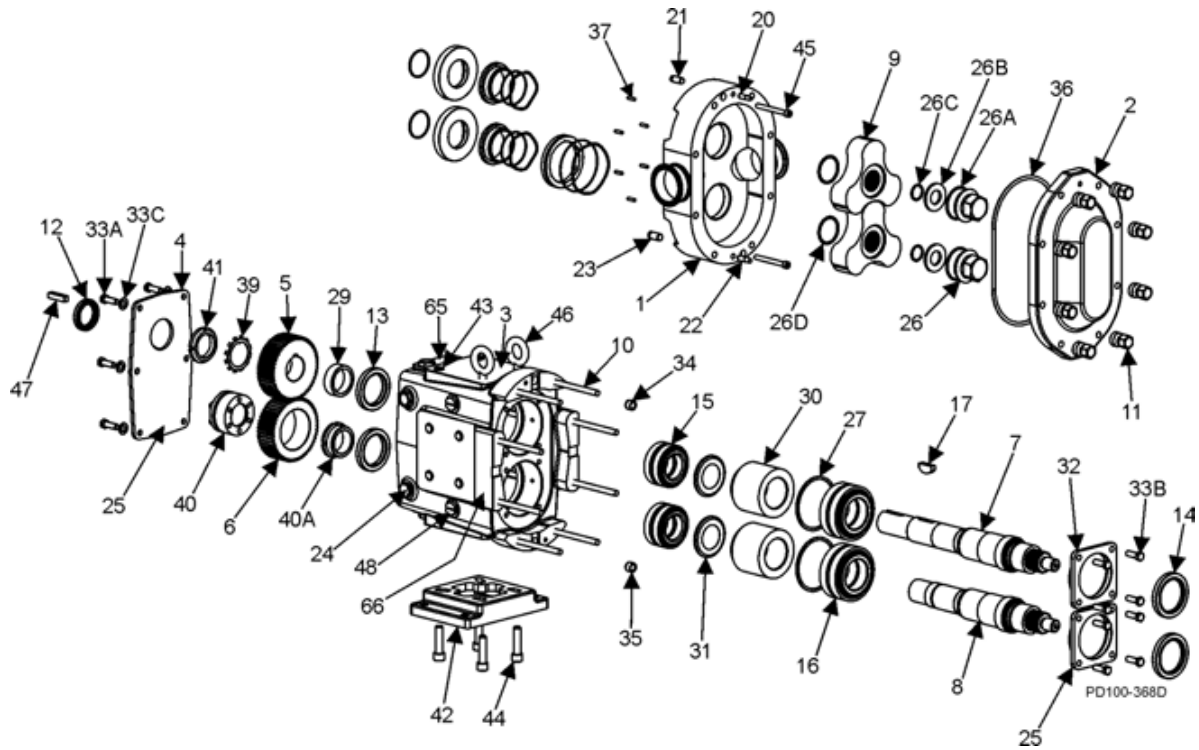

320-UL PD Pumps

ITEM NO.	DESCRIPTION	QTY. PER PUMP	PART NO.	NOTES
32	Bearing Retainer, Front	2	123533+	
33A	3/8-16 x .75" HHCS	6	30-314	
33B	5/16-18 HHCS	8	30-353	
33C	3/8" Flat Washer	6	43-189	
34	Dowel Bushings	2	OH1116000	
* * * *				
36	O-Ring, Pump Cover, Buna N	1	N70383	
	O-Ring, Pump Cover, EPDM	1	E70383	
	O-Ring, Pump Cover, FKM	1	V70383	
	O-Ring, Pump Cover, Silicone	1	S75383	
37	Stop Pin, Seal	6	102438+	
40	Locking Assembly	1	105475+	
40A	Locknut, Sleeve	1	108204+	
	Locknut, Sleeve	1	105476+	21
41	Locknut, Gear	1	105697+	
42	Gear Case Shim, CI	1	40288+	
	Pump Pedestal, 22", Optional	1	324110226+	
43	Plastic Cap Plug	8	000121001+	
44	1/2-13 x 1-3/4" HHCS	4	30-250	
44A	Lock Washer, 1/2"	4	43-177	
45	Body Retaining Screws	2	30-499	
46	Eye Bolt	3	30-360	
47	Key, Coupling - 5/8 x 5/8 x 2-3/4"	1	000037005+	
48	Cleanout Plug	2	41013+	
56	Seal Guard	2	113504+	
56A	5/16 - 18 x 1/2" HHCS	4	30-163	
61	Name Plate	1	001061015+	
62	#2 x .125" RHDS	4	30-355	
65	Caution Plate	2	121694+	
66	Warning Label	2	33-60	
67	Grease Fitting, 1/8"	4	BD0092000	
68	Plastic Cap, Grease Fitting	4	BD0093000	

PL5060-CH23

NOTES:

21. Sleeve locknut required for pump made prior to change in 1997.

* **Recommended Spare Parts**

Universal UL PD Pump Seals

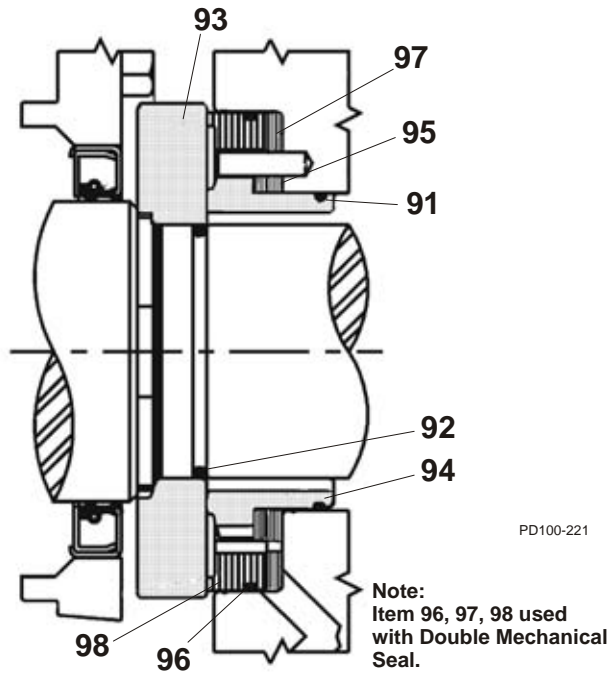

Item No.	Description	Qty. Per Pump	Part No. by Model					Notes
			018 UL	030, 034, 050, 054	060, 130, 134 UL	220 UL	320 UL	
MECHANICAL SEAL PARTS								
* 91	O-Ring, Inner Seal, Buna N	2	N70028	N70031	N70035	N70041	N70154	25
*	O-Ring, Inner Seal, EPDM	2	E70028	E70031	E70035	E70041	E70154	25
*	O-Ring, Inner Seal, FKM	2	V70028	V70031	V70035	V70041	V70154	
* 92	O-Ring, Shaft, Buna N	2	N70024	N70029	N70133	N70145	N70149	25
*	O-Ring, Shaft, EPDM	2	E70024	E70029	E70133	E70145	E70149	25
*	O-Ring, Shaft, FKM	2	V70024	V70029	V70133	V70145	V70149	
* 93	Seal Seat, Ceramic	2	101667+	101670+	101673+	101676+	105416+	
*	Seal Seat, Silicon Carbide	2	101668+	101671+	101674+	101677+	105417+	
* 94	Seal Inner, Carbon (1 Piece)	2	101651+	101655+	101659+	101663+	105412+	
*	Seal Inner, Ceramic	2	101652+	101656+	101660+	101664+	105413+	
*	Seal Inner, Silicon Carbide	2	101653+	101657+	101661+	101665+	105414+	
*	Seal Inner, Tungsten Carbide	2	101654+	101658+	101662+	101666+	105415+	
95	Wave Spring, Inner Seal	2	101683+	101685+	101687+	101689+	105419+	
* 96	O-Ring, Outer Seal, Buna N	2	N70035	N70041	N70043	N70046	N70160	8
*	O-Ring, Outer Seal, EPDM	2	N/A	E70041	E70043	E70046	E70160	8
*	O-Ring, Outer Seal, FKM	2	N/A	V70041	V70043	V70046	V70160	8
97	Wave Spring, Outer Seal	2	101684+	101686+	101688+	101690+	105420+	8
* 98	Outer Seal, Carbon	2	101679+	101680+	101681+	101682+	105418+	8

NOTES:

PL5060-CH4

8. Used with Double Mechanical Seal. (Model 018 UL uses a Single Mechanical Seal.)

25. Sold in packages of 25 only.

* **Recommended Spare Parts**

See page 45 for o-ring selections, descriptions and color codes.

Vented Cover Parts - Model 018, 030, 034, 050, 054, 060, 130, 134 UL

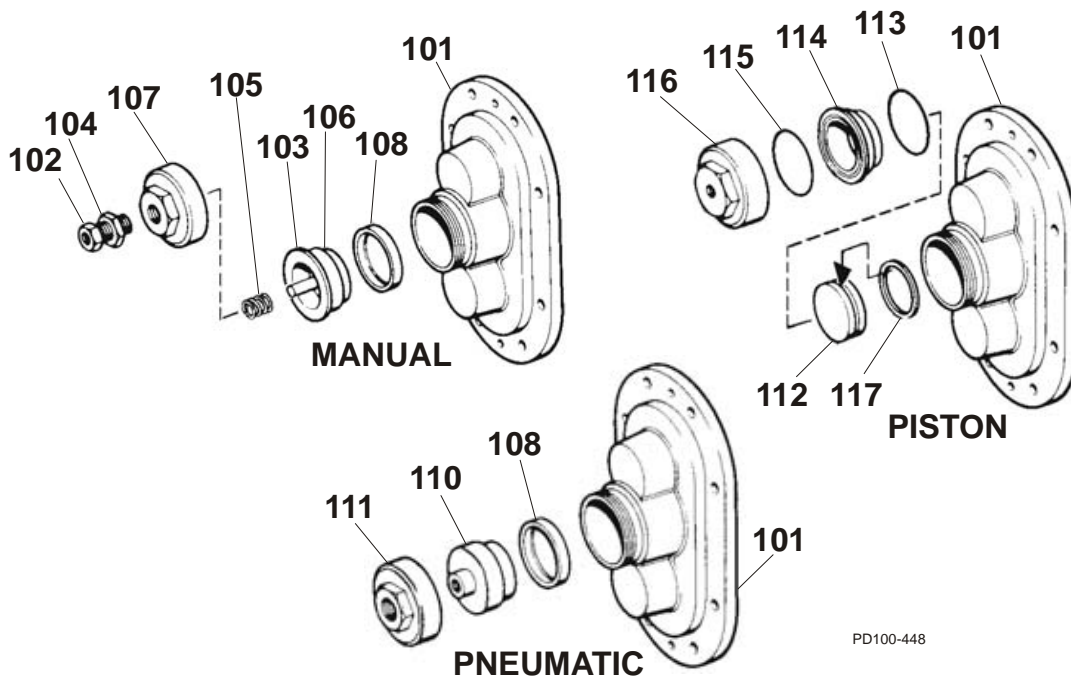

Item No.	Description	Qty. Per Pump	Part No. By Model			Notes
			018 UL	030, 034, 050, 054 UL	060, 130, 134 UL	
MANUAL VENTED COVER						
101	Vented Cover	1	103673+	103674+	103675+	
102	Adjusting Screw	1	AD0072000	AD0072000	113657+	
103	Spring Plunger	1	AD0073000	AD0073000	113397+	
104	Locknut	1	AD0074000	AD0074000	GD0074000	
105	Spring, Medium (less than 150 PSI)	1	AD0076000	AD0076000	113523+	
	Spring, High (more than 150 PSI)	1	ABB076100	ABB076100	113400+	
106	Diaphragm Bushing	1	AD0077000	AD0077000	CD0077000	
107	Cover Nut	1	AD0075000	AD0075000	113398+	
* 108	Rubber Diaphragm, Buna N	1	AD0078000	AD0078000	CD0078000	
PNEUMATIC VENTED COVER						
101	Vented Cover	1	103673+	103674+	103675+	
* 108	Diaphragm, Buna N	1	AD0078000	AD0078000	CD0078000	
110	Diaphragm Bushing	1	AD0077P00	AD0077P00	CD0077P00	
111	Cover Nut	1	AD0075P00	AD0075P00	CD0075P00	
PISTON VENTED COVER						
101	Vented Cover	1	103673+	103674+	103675+	
112	Piston	1	AD0073P10	AD0073P10	CD0073P10	
* 113	O-Ring, Bushing Seal, Buna N	1	N70223	N70223	N70239	
114	Diaphragm Bushing	1	AD0077P10	AD0077P10	CD0077P10	
* 115	O-Ring, Nut Seal, Buna N	1	N70224	N70224	N70240	
116	Cover Nut	1	AD0075P10	AD0075P10	CD0075P10	
* 117	Piston Seal, Quad Ring	1	AD0133000	AD0133000	CD0133000	9
* 117	Piston Seal, O-Ring, Buna N	1	N70218	N70218	N70236	9

NOTES:

PL5060-CH5

9. Quad Ring and O-Ring can be interchanged.

* Recommended Spare Parts

Vented Cover Parts - Model 220 UL

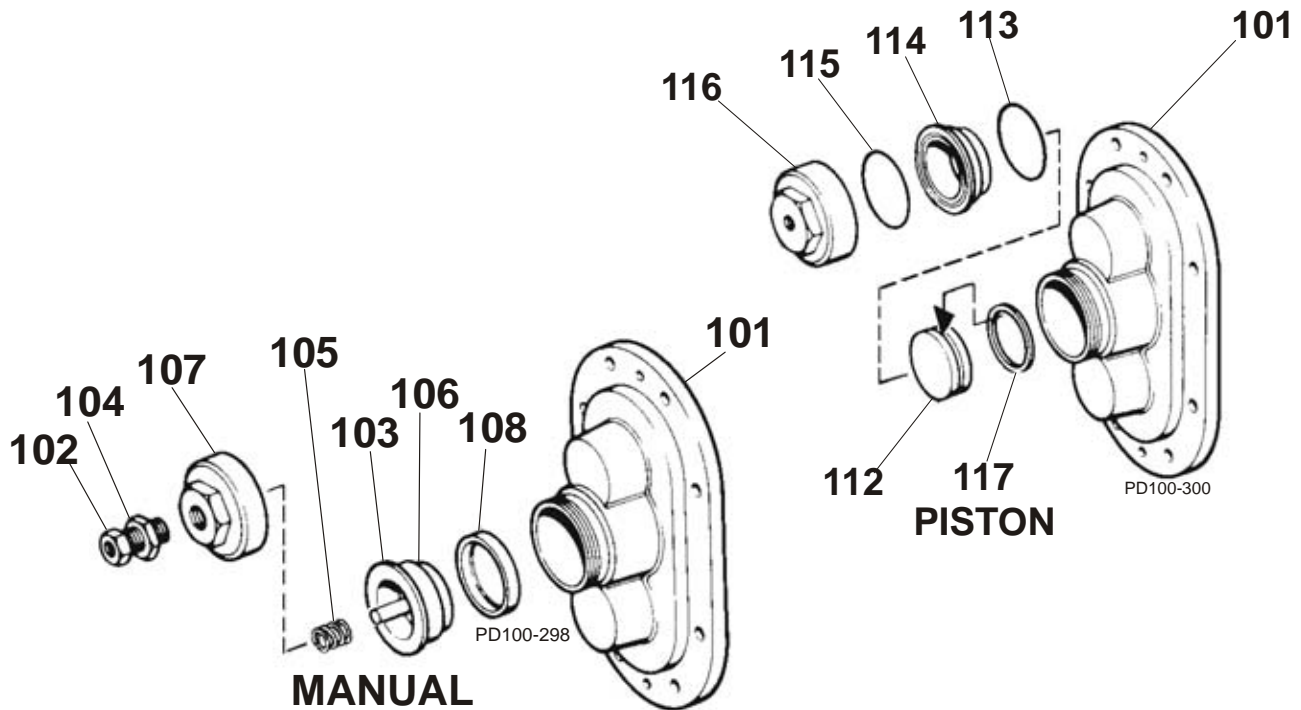

Item No.	Description	Qty. Per Pump	Part No.	Notes
MANUAL VENTED COVER				
101	Vented Cover	1	103676+	
102	Adjusting Screw	1	GD0072100	
103	Spring Plunger	1	GD0073000	
104	Locknut	1	GD0074000	
105	Spring, Medium (less than 150 PSI)	1	113400+	
	Spring, High (more than 150 PSI)	1	113524+	
106	Diaphragm Bushing	1	GD0077000	
107	Cover Nut	1	GD0075000	
* 108	Rubber Diaphragm, Buna N	1	GD0078000	
PISTON VENTED COVER				
101	Vented Cover	1	103676+	
112	Piston	1	GD0073P10	
* 113	O-Ring, Bushing Seal, Buna N	1	N70261	
114	Diaphragm Bushing	1	GD0077P10	
* 115	O-Ring, Nut Seal, Buna N	1	N70261	
116	Cover Nut	1	GD0075P10	
* 117	Piston Seal, Quad Ring	1	GD0133000	9
	Piston Seal, O-Ring, Buna N	1	N70258	9

NOTES:

PL5060-CH20

9. Quad Ring and O-Ring can be interchanged.

* Recommended Spare Parts

UL Pump Dimensions

Universal UL Pump Dimensions and Model Weights

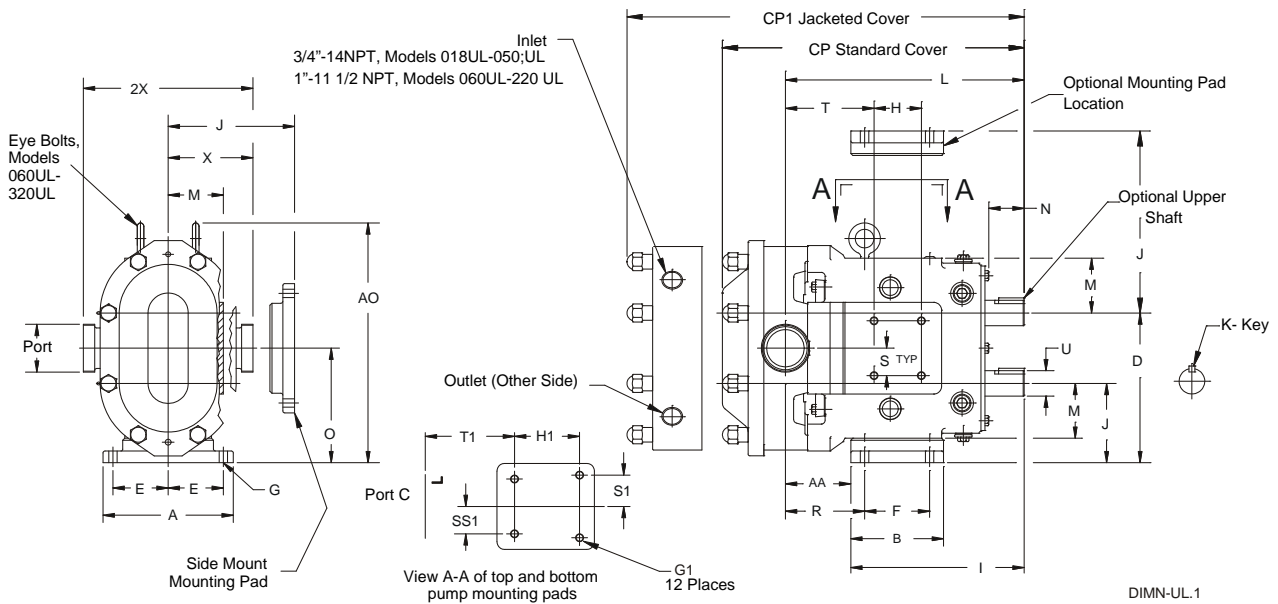

Pump Size		A	AA	AO	B	CP	CP1	D	E	F	G	G1	H	H1	I	Pump Weight
018UL	in	4.75	2.82	8.30	3.75	12.37	14.53	5.50	1.94	2.31	.41, SLOT	5/16-18x.62	2.50	2.50	7.66	56 lb
	mm	121	72	211	95	314	369	140	49	59	10, SLOT	-	64	64	194	25 kg
030UL	in	6.25	2.78	10.29	4.25	14.49	16.43	6.86	2.31	2.56	.41, SLOT	3/8-16x.62	1.81	2.75	8.83	107 lb
	mm	159	71	261	108	368	417	174	59	65	10, SLOT	-	46	70	224	49 kg
050UL	in	6.25	3.11	10.29	4.25	15.50	17.44	6.86	2.31	2.56	.41, SLOT	3/8-16x.62	1.81	2.75	8.83	116 lb
	mm	159	79	261	108	394	443	174	59	65	10, SLOT	-	46	70	224	53 kg
060UL	in	8.25	4.14	15.31	5.87	18.26	21.00	9.56	3.50	4.12	.53	1/2-13x.88	3.00	4.13	10.99	264 lb
	mm	210	105	389	149	464	533	246	89	105	.13	-	76	105	279	120 kg
130UL	in	8.25	4.14	15.31	5.87	19.28	22.02	9.56	3.50	4.12	.53	1/2-13x.88	3.00	4.13	10.99	276 lb
	mm	210	105	389	149	490	559	246	89	105	.13	-	76	105	279	125 kg
220 UL	in	8.50	3.69	19.13	9.00	23.07	25.81	12.38	3.75	7025	.53, SLOT	1/2-13x1.00	5.38	5.38	14.80	454 lb
	mm	216	94	486	229	586	655	314	95	184	.13, SLOT	-	137	137	376	206 kg
320 UL	in	12.00	3.84	22.38	11.63	26.66	-	13.88	5.25	8.00	.66	1/2-13x1.00	5.38	5.38	17.80	809 lb
	mm	305	97	568	295	677	-	353	133	203	17	-	137	137	452	367 kg

Pump Size		J	K +.000 -.001	L	M	N	O	Port Size	R	S	S1	SS1	T	T1	U +.000 -.001	X*	2X*
018UL	in	2.93	.1875	9.84	2.12	2.00	4.21	1-1/2	3.66	1.00	1.00	1.00	3.38	2.51	.875	3.55	7.09
	mm	74	4.763	250	54	51	107	-	93	25	25	25	86	64	22.23	89	177
030UL	in	3.56	.25	11.61	2.62	2.32	5.21	1-1/2	3.84	1.12	1.12	1.12	4.00	3.59	1.250	4.25	8.50
	mm	90	6.35	295	67	59	132	-	98	28	28	28	102	91	31.75	108	216
050UL	in	3.56	.25	11.94	2.62	2.32	5.21	2-1/2	4.17	1.12	1.12	1.12	4.33	3.92	1.250	4.31	8.62
	mm	90	6.35	303	67	59	132	-	106	28	28	28	110	100	31.75	109	219
060UL	in	5.06	.375	15.14	3.50	2.25	7.31	2-1/2	5.01	1.75	2.00	1.75	5.62	5.01	1.625	5.37	10.75
	mm	129	9.525	335	89	57	186	-	127	44	51	44	143	127	41.28	136	273
130UL	in	5.06	.375	15.77	3.50	2.25	7.31	3	5.65	1.75	2.00	1.75	6.25	5.66	1.625	5.37	10.75
	mm	129	9.525	401	89	57	186	-	144	44	51	44	159	144	41.28	136	273
220 UL	in	6.38	.50	18.49	4.50	.75	9.38	4	4.44	2.69	2.69	2.69	6.00	6.00	2.000	6.63	13.25
	mm	162	12.7	470	114	70	2.38	-	113	68	68	68	152	152	50.80	168	337
320 UL	in	6.88	.625	21.63	5.06	4.06	10.38	6" 150# Flange	5.09	2.69	2.69	2.69	8.09	8.37	2.375	8.00	16.00
	mm	175	15.88	549	129	103	264	-	129	68	68	68	205	213	60.45	203	406

* Dimensions "X" and "2X" apply for bevel seat, "S" Clamp, "Q" Clamp, 15l and 14l Fittings (except 320UL)

Rectangular Flange Universal UL Pump Dimensions and Model Weights

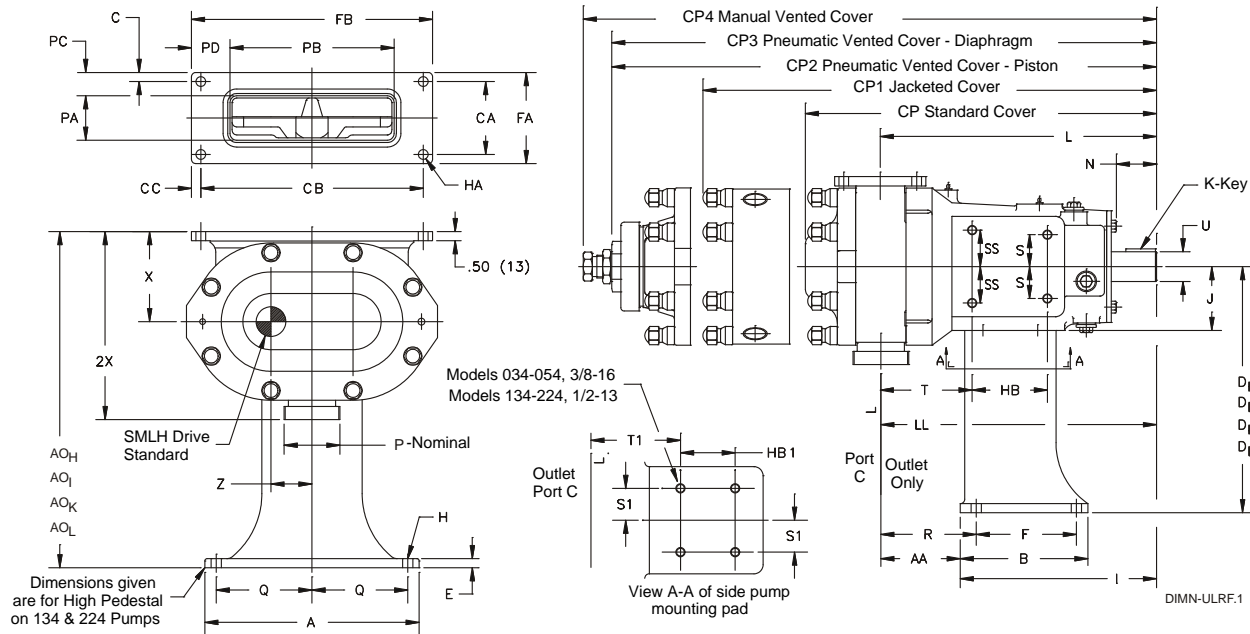

Pump Size		A	AA	AO _H	AO _I	AO _K	AO _L	B	C	CA	CB	CC	CP	CP1	CP2	CP3	CP4	Pump Weight
034UL	in	8.00	2.88	14.25	13.75	13.25	12.75	4.25	.62	1.88	10.75	.62	14.49	16.49	15.89	15.98	17.58	112 lb
	mm	203	73	362	349	337	324	108	16	48	273	16	368	419	404	406	447	51 kg
054UL	in	8.00	3.35	14.25	13.75	13.25	12.75	4.25	.62	2.88	10.50	.62	15.50	17.50	16.90	16.99	18.59	122 lb
	mm	203	85	362	349	337	324	108	16	73	267	16	394	445	429	432	472	55 kg
134UL	in	11.75	5.00	18.44	-	-	13.94	7.00	.78	3.00	14.00	.63	20.15	22.27	22.25	22.53	23.84	284 lb
	mm	298	127	468	-	-	354	178	20	76	356	16	512	566	565	572	606	129 kg
224 UL	in	15.00	4.75	23.75	-	-	19.75	9.50	.63	4.37	16.75	.63	23.07	25.81	26.52	-	28.32	452 lb
	mm	381	121	603	-	-	502	241	16	111	425	16	586	655	674	-	719	205 kg

Pump Size		D _H	D _I	D _K	D _L	E	F	FA	FB	H	HA	HB	HB1	I	J	K +.000 -.001	L	LL
034UL	in	10.38	9.88	9.38	8.88	.38	3.00	3.12	12.00	.44	.53	2.75	1.81	8.49	2.62	.25	11.36	11.37
	mm	264	251	238	226	10	76	79	305	11	13	70	46	216	67	6.35	289	289
054UL	in	10.38	9.88	9.38	8.88	.38	3.00	4.12	11.75	.44	.53	2.75	1.81	8.49	2.62	.25	11.86	11.84
	mm	264	251	238	226	10	76	105	298	11	13	70	46	216	67	6.35	301	301
134UL	in	14.25	-	-	13.50	.50	5.50	4.55	15.25	.56	.53	4.13	3.00	10.77	3.50	.375	15.78	15.76
	mm	362	-	-	343	13	140	116	387	14	13	105	76	274	89	9.525	401	400
224 UL	in	17.50	-	-	13.50	.63	8.25	5.62	18.00	.56	.53	5.38	5.38	13.74	4.50	.50	18.49	18.49
	mm	445	-	-	343	16	210	143	457	14	13	137	137	349	114	12.70	470	470

Pump Size		N	P	PA	PB	PC	PD	Q	R	S	S1	SS	T	T1	U +.000 -.001	X	2X*	Z
034UL	in	2.32	2.0	1.81	6.84	.66	2.58	3.38	3.51	1.12	1.12	1.12	3.35	3.76	1.250	3.88	8.12	1.65
	mm	59	-	46	174	17	66	86	89	28	28	28	85	96	31.75	99	206	42
054UL	in	2.32	2.5	2.37	6.87	.88	2.44	3.38	3.98	1.12	1.12	1.12	3.82	4.23	1.250	3.88	8.18	1.65
	mm	59	-	60	175	22	62	86	101	28	28	28	97	107	31.75	99	208	42
134UL	in	2.25	3.0	3.19	9.38	.68	2.94	5.25	5.87	2.00	1.75	1.75	5.65	6.25	1.625	4.94	10.31	2.25
	mm	57	-	81	238	17	75	133	149	51	44	44	144	159	41.28	125	262	57
224 UL	in	2.75	4.0	4.06	11.25	.78	3.38	6.88	5.37	2.69	2.69	2.69	6.00	6.00	2.000	6.25	12.87	3.00
	mm	70	-	103	286	20	86	175	136	68	68	68	152	152	50.80	159	327	76

* Dimension "2X" applies for bevel seat, "S" Clamp, "Q" Clamp, 15l and 14l Fittings

Troubleshooting



WARNING: To avoid serious injury, do not install or service pump unless all power is off and locked out. Shut off and drain product from pump prior to disconnecting piping.

PROBLEM	POSSIBLE CAUSE	SUGGESTED ACTION
No flow, pump not turning	Drive motor not running	Check resets, fuses, circuit breakers
	Keys sheared or missing.	Replace
	Drive belts, power transmission components slipping or broken	Replace or adjust
	Pump shaft, keys, or gears sheared	Inspect: and replace parts as necessary
No flow, pump not priming	Valve closed in inlet line	Open valve
	Inlet line clogged or restricted	Clear line, clean filters, etc.
	Air leaks due to bad seals or pipe connections	Replace gaskets; check lines for leakage (can be done by air, by pressure or by filling with liquid and pressurizing with air)
	Pump speed too slow	Increase pump speed. Filling inlet lines with fluid may allow initial start-up. Foot valve may solve start-up problems permanently.
	Liquid drains or siphons from system during off periods	Use foot valve or check valves
	"Air" lock caused by fluids which "gas off", or vaporize, or allow gas to come out of solution during off periods	Install and use a manual or automatic air bleed from pump or lines near pump
	Extra clearance rotors, worn pump	Increase pump speed, use foot valve to improve priming
	Net inlet pressure available too low	Check Net Inlet Pressure Available (NIPA) & Net Inlet Pressure Required (NIPR). Change inlet system as needed
On "Vacuum" inlet system: On initial start-up, atmospheric "blow back" prevents pump from developing enough differential pressure to start flow	Install check valve in discharge line	
Insufficient flow	Speed too low to obtain desired flow	Check flow-speed curve (available from WCB customer service) and adjust as necessary.
	Air leak due to bad seals, gadgets or pipe connections	Replace seals, check inlet fittings

PROBLEM	POSSIBLE CAUSE	SUGGESTED ACTION
Fluid vaporization (“starved” pump inlet)	Strainers, foot valves, inlet fittings or lines clogged	Clear lines. If problem continues, inlet system may require changing
	Inlet line size too small; inlet line too long; too many fittings or valves; foot valve, strainers too small.	Increase inlet line size. Reduce length, minimize direction and size changes, reduce number of fittings
	Net Inlet Pressure Available (NIPA) at Pump is too low	Raise liquid level in source tank Increase NIPA at Pump by raising or pressurizing source tank. Select larger pump size with (“starved” pump inlet) lower NIPA
	Fluid viscosity greater than expected	Reduce pump speed and accept lower flow, or change system to reduce line losses
	Fluid temperature higher than expected (vapor pressure higher).	Reduce temperature, reduce speed and accept lower flow or change system to increase Net Inlet Pressure Available.
Insufficient flow; flow being bypassed somewhere	Flow diverted in branch line, open valve, etc.	Check system and controls
Insufficient flow; high slip	Hot (HC) or extra clearance rotors on “cold” fluid, and/or low viscosity fluid	Replace with standard clearance rotors
	Worn pump	Increase pump speed (within limits) Replace rotors, recondition pump
	High pressure	Reduce pressure by adjusting system settings or hardware
Noisy operation caused by fluid	Cavitation due to high fluid viscosity. High vapor pressure fluid. High temperature	Slow down pump, reduce temperature, change system setup
	Cavitation due to Net Inlet Pressure Available (NIPA) less than Net Inlet Pressure Required (NIPR)	Increase NIPA or reduce NIPR. Contact WCB customer service if necessary
	Air or gas in fluid caused by leaks in the piping.	Check system and fix any leaks
	Air or gas in fluid caused by dissolved gas or naturally aerated products	Minimize discharge pressure (also see Cavitation, above)

PROBLEM	POSSIBLE CAUSE	SUGGESTED ACTION
Noisy operation caused by mechanical problems.	Rotor to body contact due to improper assembly of pump	Check clearances and adjust shimming
	Rotor to body contact caused by distortion of pump due to improper piping installation	Change piping installation to eliminate piping stress and distortion on body
	Pressures required higher than the pump rating	Reduce discharge pressure required
	Rotor to body contact caused by worn bearings.	Rebuild with new bearings and lubricate regularly
	Rotor to rotor contact caused by loose or mis-timed gears, twisted shaft, sheared keys or worn gears	This has caused severe damage to components - rebuild with new parts
	Drive noise caused by gear trains, chains, couplings, bearings	Repair or replace drive parts. Check bearings for damage and replace as necessary
Pump requires excessive power (overheats, stalls, high current draw, breakers trip)	Higher than expected viscosity losses	If within pump rating, increase drive size
	Higher than expected pressures	Reduce pump speed Increase line sizes
	Fluid is colder with a higher viscosity than expected	Heat fluid, insulate lines or heat trace lines Use pump with more running clearances
	Fluid sets in line and pump during shutdown	Insulate lines or heat trace lines Install a "soft start" drive Install a recirculating bypass system Flush system with a nonsetting fluid
	Fluid builds up on pump surfaces	Replace the pump with more running clearances
Short pump service life	Pumping abrasives	Larger pumps at slower speeds
	Speeds and pressures higher than rated	Reduce speeds and pressures by making changes in the system Replace pump with a large model with higher pressure ratings
	Worn bearings and gears due to lack of lubrication	Check and replace bearing and gears as necessary. Adjust lubrication schedule to decrease time between lubrication
	Misalignment of drive and piping. (Excessive over-hung load or misaligned couplings)	Check alignment of piping and drive, adjust as necessary

Notes

Holland[®]
APPLIED TECHNOLOGIES
Indianapolis • Chicago • San Juan
www.hollandapt.com
800-800-8464

SPX[®]
WHERE IDEAS MEET INDUSTRY

Your local contact:



Holland[®]
APPLIED TECHNOLOGIES
Indianapolis • Chicago • San Juan
www.hollandapt.com
800-800-8464



Waukesha Cherry-Burrell, An SPX Brand
611 Sugar Creek Road
Delavan, WI 53115
Phone: (262)728-1900 or (800)252-5200 Fax: (262)728-4904 or (800)252-5012
E-mail: wcb@spx.com

For more information about our worldwide locations, approvals, certifications, and local representatives, please visit www.spxpe.com.

SPX Corporation reserves the right to incorporate our latest design and material changes without notice or obligation. Design features, materials of construction and dimensional data, as described in this bulletin, are provided for your information only and should not be relied upon unless confirmed in writing.