

W60 and W80 Series Valves

FORM NO.: 95-03022 REVISION: 02/2016

READ AND UNDERSTAND THIS MANUAL PRIOR TO OPERATING OR SERVICING THIS PRODUCT.



Provided by:

Holland[®]
APPLIED TECHNOLOGIES
www.hollandapt.com
Phone: 800-800-8464



Waukesha Cherry-Burrell

SPX FLOW, Inc.
611 Sugar Creek Road
Delavan, WI 53115 USA

Tel: (800) 252-5200 or (262) 728-1900
Fax: (800) 252-5012 or (262) 728-4904

E-mail: wcb@spxflow.com
Web site: www.spxflow.com

Information contained in this manual is subject to change without notice and does not represent a commitment on the part of SPX FLOW, Inc. No part of this manual may be reproduced or transmitted in any form or by any means, electronic or mechanical, including photocopying and recording, for any purpose, without the express written permission of SPX FLOW, Inc.

Copyright © 2016 SPX FLOW, Inc.
All Rights Reserved.

Never-Seez is a registered trademark of Bostik Findley.
Dow Corning is a registered trademark of Dow Corning Corporation.
Loctite is a registered trademark of Henkel Loctite Corporation, U.S.A.
Tef-Flow is a trademark of SPX FLOW, Inc.

Revision Date: 02/2016

Publication: 95-03022

Warranty	6
Shipping Damage or Loss	6
Warranty Claim	6
Safety	7
Care of Stainless Steel	8
Stainless Steel Corrosion	8
Elastomer Seal Replacement Following Passivation	8
Introduction	9
General Information	9
Factory Inspection	9
Models and Specifications	9
Materials	9
Equipment Serial Number	9
Operating Parameters	10
Seal Compatibility	10
Seat Options	11
Pressure Ratings	11
Installation	12
Welding Instructions	12
Air Supply	12
Pipeline Support	12
Flow Direction	13
W80 Stem Flush Adapter	13
Operation	14
Air Connections	14
Maintainable Actuators	14
4", 5", and 6" Air-to-Raise	14
4", 5", and 6" Air-to-Lower	14
4" Air-to-Raise, 3-Position	14
4" Air-to-Lower, 3-Position	15
Adjustable-Spring Actuators	15
4", 5" and 6" Air-to-Raise, Adjustable-Spring	15
4", 5" and 6" Air-to-Lower, Adjustable-Spring	15
Maintenance-Free Actuators	16
A, B and C Size Air-to-Raise, Maintenance-Free	16
A, B and C Size Air-to-Lower, Maintenance-Free	16
Pressure Setting	17
Air-To-Raise, Adjustable-Spring Actuator	17
Air-to-Lower, Adjustable-Spring Actuator	17
Maintenance	18
Maintenance Intervals	18
Inspection	18
Lubrication	18
Cleaning	18
Valve Removal	19
W61/W81 Valve Disassembly	20
W61/W81 Valve Assembly	21
W61Y Valve Disassembly	22
W61Y Valve Assembly	23
W62/W82 Valve Disassembly	24
W62/W82 Valve Assembly	25
W63/W83 Valve Disassembly	26
W63/W83 Valve Assembly	27
W64/W84 Valve Disassembly	28
W64/W84 Valve Assembly	29
W64R/W84R Valve Disassembly	30

W64R/W84R Valve Assembly	31
W64ET/W84ET Valve Disassembly	32
W64ET/W84ET Valve Assembly	33
W65/W85 Valve Disassembly	34
W65/W85 Valve Assembly	36
Seat Replacement	37
Standard Tef-Flow™ Seat	37
Tef-Flow™ P Seat	37
Standard Tri Ring Seat	38
Servicing Actuators: U-cups, O-rings and Bearings	39
Valves with Control Module	39
O-ring and Bearing Replacement: 4", 5" and 6" Actuator	39
U-cup Replacement: 4" and 5" Actuator	40
O-ring and Bearing Replacement: 6" Actuator	40
U-cup, O-ring and Bearing Replacement:	
4" Air-to-Raise 3-Position Actuator	41
U-cup, O-ring and Bearing Replacement:	
4" Air-to-Lower 3-Position Actuator	42
O-ring and Bearing Replacement: Maintenance-Free Actuator	43
O-ring and Bearing Replacement:	
4", 5" and 6" Adjustable-Spring Actuator	44
Reversing the Spring Action on the Maintenance-Free Actuator	46
Reversing the Spring Action on the Maintainable Actuator	47
Parts Lists	48
W61/W81 Shutoff Valve	48
W61Y Shutoff Valve	50
W62/W82 Divert Valve	52
W63/W83 Reverse Shutoff Valve	54
W64/W84 Tank Outlet Valve	56
W64R/W84R Tank Outlet Valve	58
W64ET Tank Outlet Valve	60
W65/W85 Non-Slam Divert Valve	62
W60/W80 Series Single Seat Valve Bodies - inch O.D. Tube sizes	65
4" (101 mm) and 5" (127 mm) Air-to-Spring or Air-to-Air Actuators	66
6" (152 mm) Air-to-Spring or Air-to-Air Actuators	68
4" (101 mm) and 6" (152 mm) Air-to-Spring Long Stroke Actuator	70
6" (152 mm) Air-to-Air Long Stroke Actuator	72
4" (101 mm) Air-to-Raise 3-Position Actuator	74
4" (101 mm) Air-to-Lower 3-Position Actuator	76
4" (101 mm), 5" (127 mm) and 6" (152 mm)	
Air-to-Raise Adjustable-Spring Actuator	78
4" (101 mm), 5" (127 mm) and 6" (152 mm)	
Air-to-Lower Adjustable-Spring Actuator	79
Maintenance Free Actuator	80
Maintenance Free Actuator Cap	81
Hand Lock Manual Handle	82
Hand Lock Long Stroke Manual Handle	83
Micrometer Handle	84
Installation Tools	85
Tef-Flow™ P Tools	85
Tri-Ring Tool	86
Troubleshooting	87

Warranty

Seller warrants its products to be free from defect in materials and workmanship for a period of one (1) year from the date of shipment. This warranty shall not apply to products which require repair or replacement due to normal wear and tear or to products which are subjected to accident, misuse or improper maintenance. This warranty extends only to the original Buyer. Products manufactured by others but furnished by Seller are exempted from this warranty and are limited to the original manufacturer's warranty.

Seller's sole obligation under this warranty shall be to repair or replace any products that Seller determines, in its discretion, to be defective. Seller reserves the right either to inspect the products in the field or to request their prepaid return to Seller. Seller shall not be responsible for any transportation charges, duty, taxes, freight, labor or other costs. The cost of removing and/or installing products which have been repaired or replaced shall be at Buyer's expense.

Seller expressly disclaims all other warranties, express or implied, including without limitation any warranty of merchantability of fitness for a particular purpose. The foregoing sets forth Seller's entire and exclusive liability, and Buyer's exclusive and sole remedy, for any claim of damages in connection with the sale of products. In no event shall Seller be liable for any special consequential incidental or indirect damages (including without limitation attorney's fees and expenses), nor shall Seller be liable for any loss of profit or material arising out of or relating to the sale or operation of the products based on contract, tort (including negligence), strict liability or otherwise.

Shipping Damage or Loss

If equipment is damaged or lost in transit, file a claim at once with the delivering carrier. The carrier has signed the Bill of Lading acknowledging that the shipment has been received from SPX FLOW in good condition. SPX FLOW is not responsible for the collection of claims or replacement of materials due to transit shortages or damages.

Warranty Claim

Warranty claims must have a **Returned Goods Authorization (RGA)** from the Seller before returns will be accepted.

Claims for shortages or other errors, exclusive of transit shortages or damages, must be made in writing to Seller within ten (10) days after delivery. Failure to give such notice shall constitute acceptance and waiver of all such claims by Buyer.

Safety

READ AND UNDERSTAND THIS MANUAL PRIOR TO INSTALLING, OPERATING, OR SERVICING THIS EQUIPMENT

SPX FLOW recommends users of our equipment and designs follow the latest Industrial Safety Standards. At a minimum, these should include the industrial safety requirements established by:

1. Occupational Safety and Health Administration (OSHA), Title 29 of the CFR
Section 1910.212- General Requirements for all Machines
2. National Fire Protection Association, ANSI/NFPA 79
ANSI/NFPA 79- Electrical Standards for Industrial Machinery
3. National Electrical Code, ANSI/NFPA 70
ANSI/NFPA 70- National Electrical Code
ANSI/NFPA 70E- Electrical Safety Requirement for Employee Workplaces
4. American National Standards Institute, Section B11

Attention: Servicing energized industrial equipment can be hazardous. Severe injury or death can result from electrical shock, burn, or unintended actuation of controlled equipment. Recommended practice is to disconnect and lockout industrial equipment from power sources, and release stored energy, if present. Refer to the National Fire Protection Association Standard No. NFPA70E, Part II and (as applicable) OSHA rules for Control of Hazardous Energy Sources (Lockout-Tagout) and OSHA Electrical Safety Related Work Practices, including procedural requirements for:

- Lockout-tagout
- Personnel qualifications and training requirements
- When it is not feasible to de-energize and lockout-tagout electrical circuits and equipment before working on or near exposed circuit parts

Locking and Interlocking Devices: These devices should be checked for proper working condition and capability of performing their intended functions. Make replacements only with the original manufacturer's renewal parts or kits. Adjust or repair in accordance with the manufacturer's instructions.

Periodic Inspection: Industrial equipment should be inspected periodically. Inspection intervals should be based on environmental and operating conditions and adjusted as indicated by experience. At a minimum, an initial inspection within 3 to 4 months after installation is recommended. Inspection of the electrical control systems should meet the recommendations as specified in the National Electrical Manufacturers Association (NEMA) Standard No. ICS 1.3, Preventative Maintenance of Industrial Control and Systems Equipment, for the general guidelines for setting-up a periodic maintenance program.

Replacement Equipment: Use only replacement parts and devices recommended by the manufacturer to maintain the integrity of the equipment. Make sure the parts are properly matched to the equipment series, model, serial number, and revision level of the equipment.

Warnings and cautions are provided in this manual to help avoid serious injury and/or possible damage to equipment:



DANGER: marked with a stop sign.
Immediate hazards which WILL result in severe personal injury or death.



WARNING: marked with a warning triangle.
Hazards or unsafe practices which COULD result in severe personal injury or death.



CAUTION: marked with a warning triangle.
Hazards or unsafe practices which COULD result in minor personal injury or product or property damage.

Care of Stainless Steel

NOTE: *SPX FLOW* recommends the use of an FDA-approved anti-seize compound on all threaded connections.

Stainless Steel Corrosion

Corrosion resistance is greatest when a layer of oxide film is formed on the surface of stainless steel. If film is disturbed or destroyed, stainless steel becomes much less resistant to corrosion and may rust, pit or crack.

Corrosion pitting, rusting and stress cracks may occur due to chemical attack. Use only cleaning chemicals specified by a reputable chemical manufacturer for use with 300 series stainless steel. Do not use excessive concentrations, temperatures or exposure times. Avoid contact with highly corrosive acids such as hydrofluoric, hydrochloric or sulfuric. Also avoid prolonged contact with chloride-containing chemicals, especially in presence of acid. If chlorine-based sanitizers are used, such as sodium hypochlorite (bleach), do not exceed concentrations of 150 ppm available chlorine, do not exceed contact time of 20 minutes, and do not exceed temperatures of 104°F (40°C).

Corrosion discoloration, deposits or pitting may occur under product deposits or under gaskets. Keep surfaces clean, including those under gaskets or in grooves or tight corners. Clean immediately after use. Do not allow equipment to set idle, exposed to air with accumulated foreign material on the surface.

Corrosion pitting may occur when stray electrical currents come in contact with moist stainless steel. Ensure all electrical devices connected to the equipment are correctly grounded.

Elastomer Seal Replacement Following Passivation

Passivation chemicals can damage product contact areas of this equipment. Elastomers (rubber components) are most likely to be affected. Always inspect all elastomer seals after passivation is completed. Replace any seals showing signs of chemical attack. Indications may include swelling, cracks, loss of elasticity or any other noticeable changes when compared with new components.

Introduction

For control top information, please refer to publication 95-03083. For additional product information, please see our website at www.spxflow.com/en/waukesha-cherry-burrell/resources/product-literature.

General Information

Information in this manual should be read by all personnel involved in installation, setup, operation and maintenance of W60/W80 valves.

Always use installation tools and lubricants recommended by SPX FLOW. Waukesha Cherry-Burrell brand products are subject to intensive intermediate and final leakage and functional tests.

W60/W80 Series valves meet 3-A and EHEDG standards for sanitation, design and style.

Factory Inspection

Each Waukesha Cherry-Burrell brand valve is shipped completely assembled, lubricated and ready for use.

Models and Specifications

Materials

- Product Wetted: ASTM 316L
(UNS-S31603); (DIN-1.4404)
- Non-Product: ASTM 304
(UNS-S30400); (DIN-1.4301)
- Seat Material: Tef-Flow™ (standard)
Tef-Flow™ P (optional)
Tri Ring (optional)
Metal (optional)
Bonded (optional)
- Elastomers: FKM (standard)
EPDM (optional)

Equipment Serial Number

Waukesha Cherry-Burrell brand valves are identified by a serial number found on the label on the actuator cylinder.

Operating Parameters

Temperature Range:

The recommended operating temperature is determined by the material used for the seals.

No special precautions are required for applications within a temperature range of 32°F to 180°F (0°C to 82°C).

For applications above 190°F (88°C), clearances can be affected by excessive thermal expansion when the valve is installed in compact fabrications or manifolds. Valve bodies have thicker cross-sections than tubing, but thermal expansion can affect clearances in interconnecting piping sections.

If operating below 32°F (0°C):

- Control air must have an appropriately low dew point.
- Valve stems must be protected from icing to ensure long working life for valve stem seals.

Solenoid valves may not be used in the control module in room environments below 32°F (0°C) and over 140°F (60°C), as function cannot be guaranteed.

Seal Compatibility

Table 1: Seal Compatibility for FKM/EPDM Seals

	Fluorelastomer (FKM) Seals	EPDM Seals
Thermal Range of Application	32°F to 375°F (0°C to 190°C)	0°F to 275°F (-18°C to 135°C)
Chemical Resistance	Silicone oil and grease	Silicone oil and grease
	Ozone, aging and weather resistant	Ozone, aging and weather resistant
	Oils and fats	Hot water and steam up to 275°F (135°C)
	Aliphatic, chlorinated and aromatic hydrocarbons	
Cleaning agents, soda and potassium alkalis		
Not compatible with	Superheated steam	Mineral oil products (oils, greases and fuels)
	Formic and acetic acids	

Contact SPX FLOW Application Engineering for other fluid compatibility.

FKM and EPDM seals comply with FDA regulations.

Seat Options

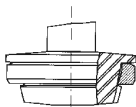
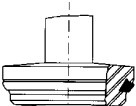
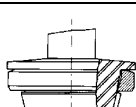
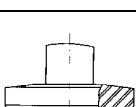
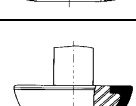
Seat Type	Maximum Temperature	Application
Standard  Tef-Flow™ (TF) White in color	180°F (82°C)*	Standard seat of choice. General Purpose >90% of applications
Standard  Tri Ring (TR) EPDM, FKM	Operation 280°F (137°C) EPDM Sterile 275°F (135°C) EPDM Operation 350°F (176°C) FKM Sterile (Consult Factory) FKM	High Pressure Particulate EHEDG
Optional  Tef-Flow™ P (TFP) Gray in color	280°F (137°C)	High Temperature High Pressure Over Pressure Valves
Optional  Metal (M)	375°F (190°C)	High Pressure High Flow Particulate
Optional  Bonded (B) EPDM, FKM	230°F (110°C)	Particulate

For higher temperature applications than those listed, please consult factory.

*Operating conditions such as flow rate and pressure must be considered when operating near maximum temperature rating.

Pressure Ratings

Standard

Valve Size with pressure at:	1.0/1-1/2" 25/40 mm	2.0" 50 mm	2-1/2" 65 mm	3.0" 80 mm	4.0" 100 mm	6.0"* 150 mm
70°F (20°C)	500 psi (34.5 bar)	450 psi (31 bar)	400 psi (28 bar)	350 psi (24 bar)	200 psi (14 bar)	150 psi (10 bar)
160 /180°F (71/82°C)	375 psi (26 bar)	350 psi (24 bar)	300 psi (17 bar)	250 psi (17 bar)	150 psi (10 bar)	100 psi (6 bar)
250°F (121°C)	250 psi (17 bar)	250 psi (17 bar)	200 psi (14 bar)	150 psi (10 bar)	125 psi (8.6 bar)	75 psi (5 bar)

Optional High Pressure Adapter and Clamps

Valve Size with pressure at:	1.0/1-1/2" 25/40 mm	2.0" 51 mm	2-1/2" 65 mm	3.0" 80 mm	4.0" 100 mm	6.0"* 150 mm
70°F (20°C)	1220 psi (84 bar)	900 psi (62 bar)	720 psi (49 bar)	--	--	--
160 /180°F (71/82°C)	1160 psi (80 bar)	855 psi (60 bar)	690 psi (47 bar)	--	--	--
250°F (121°C)	1100 psi (75 bar)	830 psi (57 bar)	660 psi (45 bar)	--	--	--

* High pressure clamp is not available for 3", 4", 6", 80mm, 100mm, 150mm.

Installation



WARNING: To avoid electrocution, ALL electrical work should be done by a registered electrician, following industrial safety standards and local codes. All power must be OFF and Locked Out during installation.

When installing valves, ensure that no foreign materials (e.g. tools, screws, welding wire, lubricants, cloths, etc.) are enclosed in the system.

Welding Instructions



CAUTION: Inspect each valve prior to installation. When using butt-weld connections on two- and three-piece body valves, clamp connections MUST be used on one or more bodies to allow service to the body o-ring(s) after installation.

W60/W80 valves with welded connections require the following before welding:

1. Remove the stem and actuator assembly. See “Valve Removal” on page 19.
2. Remove all seals from the body.
3. Weld the body into position, ensuring that the connection is free of tension and distortion.
4. Dissipate heat away from the valve body to prevent warping.

Air Supply

Install the valves using dry, filtered air. Lubrication is not required. If using lubricated air, refer to the solenoid manufacturer’s specifications.

Pipeline Support

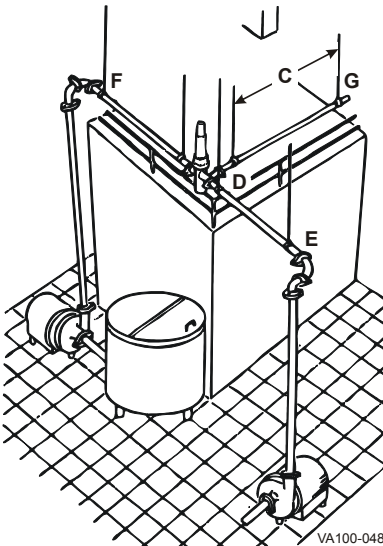

Figure 1: Pipeline Support

Install adequate supports to prevent strain on the fittings, valves, and equipment connections.

1. Install supports at least every 10 feet (3 meters) on straight runs of piping (Figure 1, item C).
2. Install supports on both sides of the valves as close as possible to the connections (Figure 1, item D).
3. Install supports at each change of pipeline direction (Figure 1, item E and F).
4. For pipelines passing through walls, floors or ceilings, provide at least 1 inch (25 mm) of clearance around the pipe to allow for expansion and contraction (Figure 1, item G).

Flow Direction

Install the valves to close against the flow to prevent hammering.

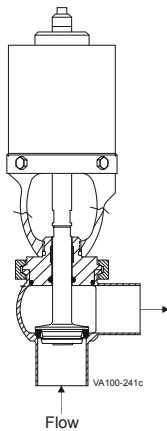

Figure 2: Flow Direction

W80 Stem Flush Adapter

W80 Series valves utilize a stem flush adapter to provide a liquid or steam barrier around the valve stem. W80 valves are designed for 14.5 psi (1 bar) maximum flush pressure with 1/4" (6.35 mm) tube O.D. connections.

Operation

Air Connections

NOTE: Actual air pressure values may vary depending on the valve size, actuator size, holding pressure requirements and spring selection.

Maintainable Actuators

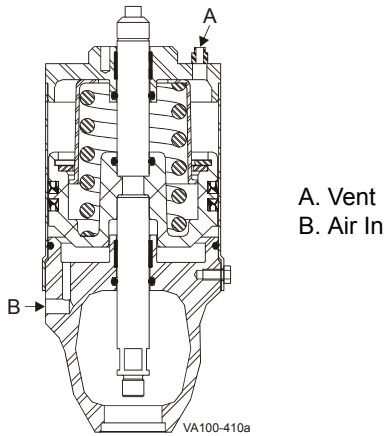

Figure 3: 4", 5", and 6" Air-to-Raise

4", 5", and 6" Air-to-Raise

- 4" and 5" Air Pressure Range = minimum 50 psi to maximum 90 psi (min. 3.4 bar to max. 6.1 bar)
- 6" Air Pressure Range = minimum 75 psi to maximum 90 psi (min. 5.1 bar to max. 6.1 bar)
- 1/8"-27 NPT Thread

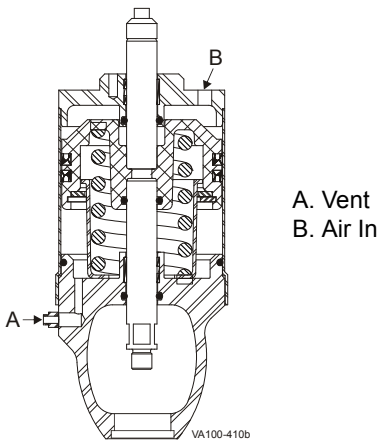

Figure 4: 4", 5", and 6" Air-to-Lower

4", 5", and 6" Air-to-Lower

- 4" and 5" Air Pressure Range = minimum 50 psi to maximum 90 psi (min. 3.4 bar to max. 6.1 bar)
- 6" Air Pressure Range = minimum 75 psi to maximum 90 psi (min. 5.1 bar to max. 6.1 bar)
- 1/8"-27 NPT Thread

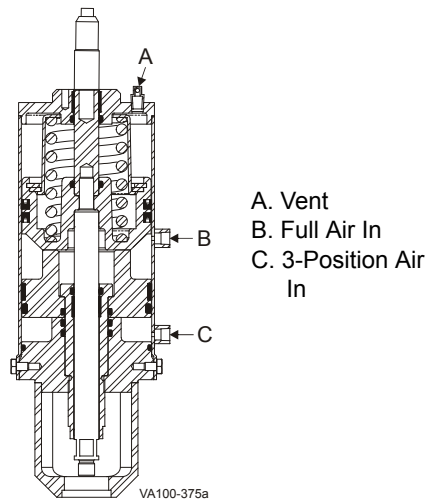

Figure 5: 4" Air-to-Raise, 3-Position

4" Air-to-Raise, 3-Position

- 4" and 5" Air Pressure Range = minimum 50 psi to maximum 90 psi (3.4 bar to 6.1 bar)
- 6" Air Pressure Range = minimum 75 psi to maximum 90 psi (5.1 bar to 6.1 bar)
- 1/8"-27 NPT Thread

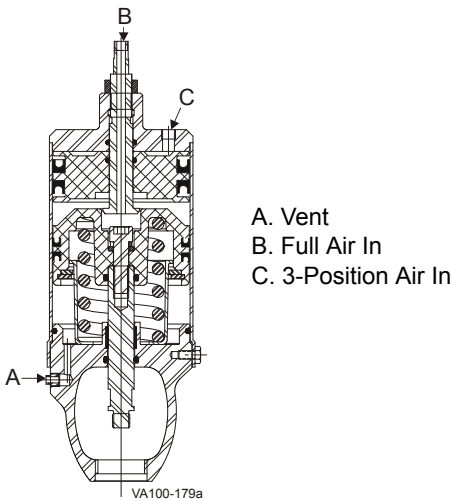

Figure 6: 4" Air-to-Lower, 3-Position

4" Air-to-Lower, 3-Position

- 4" and 5" Air Pressure Range = minimum 50 psi to maximum 90 psi (3.4 bar to 6.1 bar)
- 6" Air Pressure Range = minimum 75 psi to maximum 90 psi (5.1 bar to 6.1 bar)
- 1/8"-27 NPT Thread

Adjustable-Spring Actuators

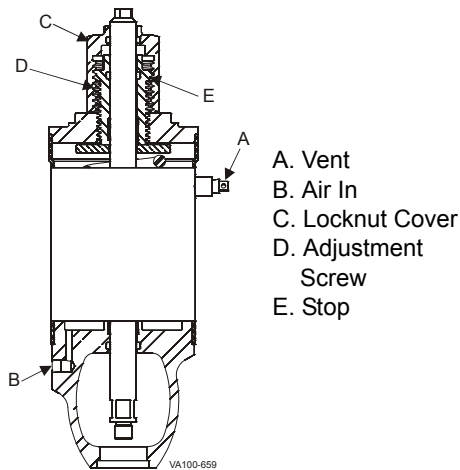

Figure 7: 4", 5" and 6" Air-to-Raise, Adjustable-Spring

4", 5" and 6" Air-to-Raise, Adjustable-Spring

- 4" and 5" Air Pressure Range = minimum 75 psi to maximum 90 psi (3.4 bar to 6.1 bar)
- 6" Air Pressure Range = minimum 75 psi to maximum 90 psi (5.1 bar to 6.1 bar)
- 1/8"-27 NPT Thread

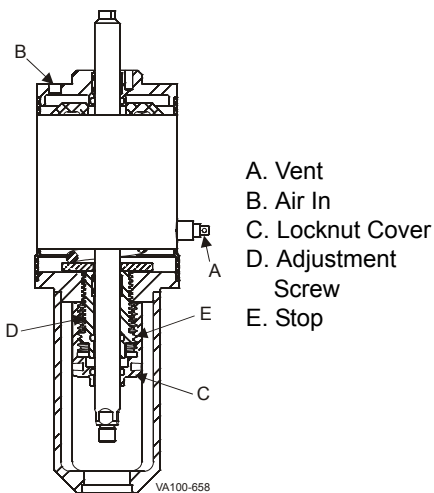

Figure 8: 4", 5" and 6" Air-to-Lower, Adjustable-Spring

4", 5" and 6" Air-to-Lower, Adjustable-Spring

- 4" and 5" Air Pressure Range = minimum 75 psi to maximum 90 psi (3.4 bar to 6.1 bar)
- 6" Air Pressure Range = minimum 75 psi to maximum 90 psi (5.1 bar to 6.1 bar)
- 1/8"-27 NPT Thread

Maintenance-Free Actuators

Figure 9: A, B and C Size Air-to-Raise, Maintenance-Free

A, B and C Size Air-to-Raise, Maintenance-Free

- A, B and C Size Air Pressure Range = 87-120 psi (6-8 bar)
- 1/8" BSPP x 1/4" OD Thread

A, B and C Size Air-to-Lower, Maintenance-Free

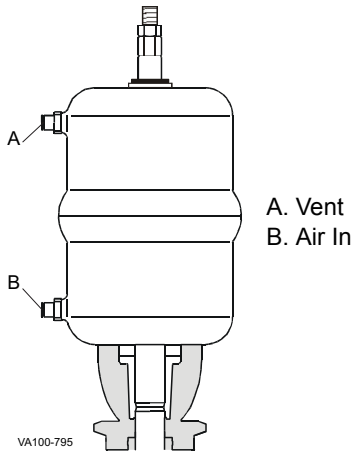
- A, B and C Size Air Pressure Range = 87-120 psi (6-8 bar)
- 1/8" BSPP x 1/4" OD Thread

NOTE: The actuator shown in Figure 9 is in air-to-raise configuration; if it is configured for air-to-lower, port A becomes Air In and port B becomes Vent.

Pressure Setting



CAUTION: Do not use vice-grips, channel locks, or pipe wrenches, as damage to the adjustment screw can result.

Table 2: Spring Setting for Air-to-Raise, Adjustable-Spring Actuator

Pressure change per turn of adjusting screw			
Plug Size	Actuator		
	4RHAR	5RHAR	6RHAR
1.5" 40 mm	24	40	82
2.0" 50 mm	13	23	46
2.5" 65 mm	9	15	29
3.0" 80 mm	6	10	20
4.0" 100 mm	3	6	12



CAUTION: Do not use vice-grips, channel locks, or pipe wrenches, as damage to the adjustment screw can result.

Table 3: Spring Setting for Air-to-Lower, Adjustable-Spring Actuator

Pressure change per turn of adjusting screw			
Plug Size	Actuator		
	4RHAL	5RHAL	6RHAL
2.0" 50 mm	16	26	44
2.5" 65 mm	9	16	27
3.0" 80 mm	6	11	18
4.0" 100 mm	3	6	9

Air-To-Raise, Adjustable-Spring Actuator

Remove locknut cover (Figure 7). Using a 1" hex wrench or 1/4" spanner, turn down the adjustment screw fully, until the stop contacts the actuator can (approx. 8-9 turns).

This is the maximum holding pressure setting. Refer to publication DS-1201, W60 Series Shut-Off & Divert Valves, for pressure holding charts for the actuator size and valve seat size: W61, W62, W65 Air-to-Raise.

NOTE: In some cases, the valve seat size may be less than the body size (reduced-seat options). Be sure to check holding pressures using the correct seat size and actuator diameter size.

To reduce the pressure setting below the maximum, unscrew the adjustment screw as per Table 2. Check and confirm specific settings with a master gauge under pressure; adjust as required. Once the setting is achieved, apply a scribe line to the indicator stem to mark the position.

Actual pressure change per turn of the adjusting screw may be different due to spring variations.

Air-to-Lower, Adjustable-Spring Actuator

Unscrew the locknut cover (Figure 8 on page 15). The cover will stay in the yoke area. Using a 1" hex wrench or 1/4" spanner, turn the adjustment screw in fully, until the stop contacts the actuator can (approx. 8-9 turns).

This is the maximum holding pressure setting. Refer to publication DS-1201, W60 Series Shut-Off & Divert Valves, for pressure holding charts for the actuator size and valve seat size: W63, W62, W65 Air-to-Lower.

NOTE: In some cases, the valve seat size may be less than the body size (reduced-seat options). Be sure to check holding pressures using the correct seat size and actuator diameter size.

To reduce the pressure setting below the maximum, unscrew the adjustment screw as per Table 3. Check and confirm specific settings with a master gauge under pressure; adjust as required. Once the setting is achieved, apply a scribe line to the indicator stem to mark the position.

Actual pressure change per turn of the adjusting screw may be different due to spring variations.

Maintenance

Maintenance Intervals

Maintain adequate stock of replacement parts. See the items in bold beginning on page 48 for recommended spare parts.

Maintenance intervals should be determined by the user and specific application, based on the following conditions:

- Daily operation period
- Switching frequency
- Application parameters such as temperature, pressure, and flow
- Product type

Inspection

Inspect the following on a regular basis:



DANGER: Do not put a hand into the yoke or body of a pneumatically actuated valve.

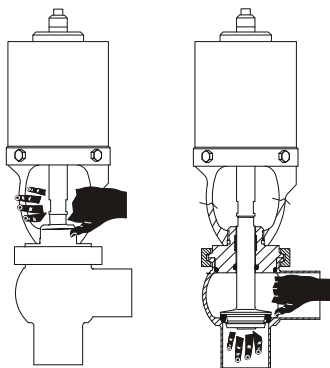

VA100-359a

- Actuator connections for air leaks
- Valve body and stem o-rings
- Valve seats (If leakage occurs, see “Troubleshooting” on page 87)
- Pneumatic connections:
 - Air pressure at supply connection
 - Air lines for kinks and leaks
 - Threaded connections for tight fit
 - Threaded stress relief for tight fit
- Electrical connections secure on the control module:
 - Wire connections tight on the terminal strip
 - Clean air filter at regular intervals.

Lubrication

No lubrication is required other than as noted in the disassembly and assembly procedures. (Use food grade non-petroleum (silicone) grease on seals and o-rings.)

Apply Bostik Never-Seez[®] White Food Grade with PTFE or equivalent to all bolts and threaded stem parts.

Cleaning

NOTE: Actuate each valve a minimum of twice each cycle to ensure effective cleaning and sanitizing.



CAUTION: Avoid splashing any liquid into the air vent of the actuator during clean up.

Cleaning-In-Place (CIP)

CIP methods can be used to clean installed automatic valves without disassembly. Select methods based on the specific requirements of sanitarians and each application. Check with local chemical suppliers for the most effective cleaning agents and procedures.

Valve Removal

Before detaching the port connections on the valve body, perform the following:

1. Clean, rinse and drain the pipe system elements attached to the valve.
2. Remove or block the fluid and gas lines to prevent material from entering the pipe system elements attached to the valve.
3. Shut off the delivery of the control air unless it is required for the removal of the valve stem/actuator assembly from the body.
4. Disconnect the electrical supply and lockout all power.
5. If the valve has a control module with solenoid, the air and electric supply must remain ON until the valve is properly disassembled.

W61/W81 Valve Disassembly

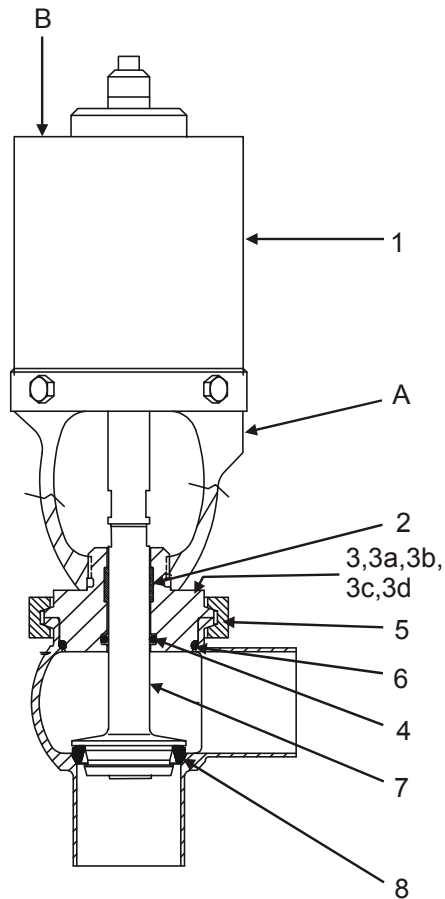

VA100-241b

**Figure 10: W61/W81 Shut Off Valve
(Air-to-Raise Shown)**

Air-to-Raise Actuator

1. Apply air to Port A to raise the stem.
2. Remove the body clamp (Figure 10, item 5).
3. Release the air pressure.
4. Remove the body from the adapter (item 3). For two-piece bodies, un-clamp and remove the lower body first.
5. Shut off the air and disconnect the air line to the actuator.
6. For valves with control modules, disconnect/lockout the electrical power to the valve.
7. Using 5/8-inch wrench flats on the stem, unscrew and remove the valve stem (item 7).
8. Replace the seat ring (item 8) as needed. See "Seat Replacement" on page 37.
9. Unscrew the adapter (item 3) from the yoke.
10. Remove the body o-ring (item 6) and stem o-ring (item 4); replace them as needed.
11. Inspect and replace the PTFE bearing (item 2) as needed.

Air-to-Lower Actuator

1. Shut off the air and disconnect the air line to the actuator at Port B.
2. For valves with control modules, disconnect/lockout the electrical power to the valve.
3. Remove the body clamp (item 5) and body from the adapter (item 3). For two-piece bodies, un-clamp and remove the lower body first.
4. Using 5/8-inch wrench flats on the stem, unscrew and remove the valve stem (item 7).
5. Replace the seat ring (item 8) as needed. See "Seat Replacement" on page 37.
6. Unscrew the adapter (item 3) from the yoke.
7. Remove the body o-ring (item 6) and stem o-ring (item 4); replace them as needed.
8. Inspect and replace the PTFE bearing (item 2) as needed.

W61/W81 Valve Assembly**Air-to-Raise Actuator**

1. Screw the adapter (Figure 11, item 3) onto the yoke.
2. Install the body o-ring (item 6), stem o-ring (item 4), and PTFE bearing (item 2).
3. Using 5/8-inch torque wrench flats on the stem, install the valve stem (item 7). Torque to 380 in/lbs.
4. Apply air to Port A to raise the stem.
5. Assemble the body to the adapter; secure it with the body clamp (item 5).
6. Release the air pressure.

Air-to-Lower Actuator

1. Screw the adapter (item 3) onto the yoke.
2. Install the body o-ring (item 6), stem o-ring (item 4), and PTFE bearing (item 2).
3. Using 5/8-inch torque wrench flats on the stem, install the valve stem (item 7). Torque to 380 in/lbs.
4. Assemble the body to the adapter; secure it with the body clamp (item 5).

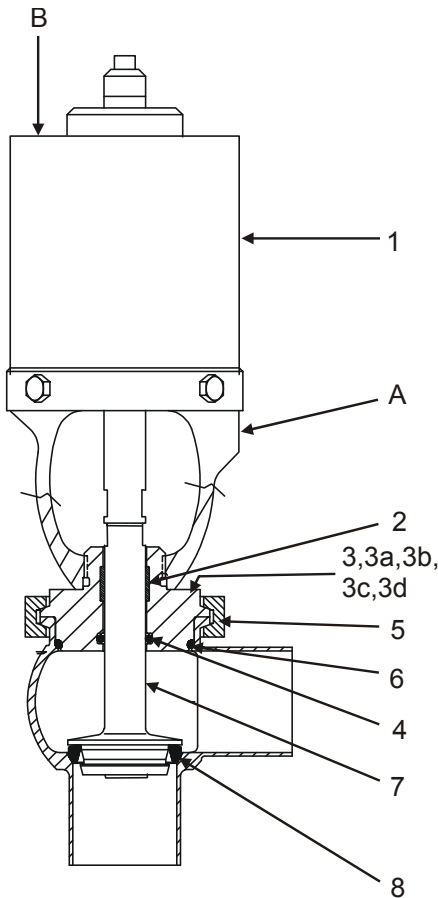

VA100-241b

**Figure 11: W61/W81 Shut Off Valve
(Air-to-Raise Shown)**

W61Y Valve Disassembly

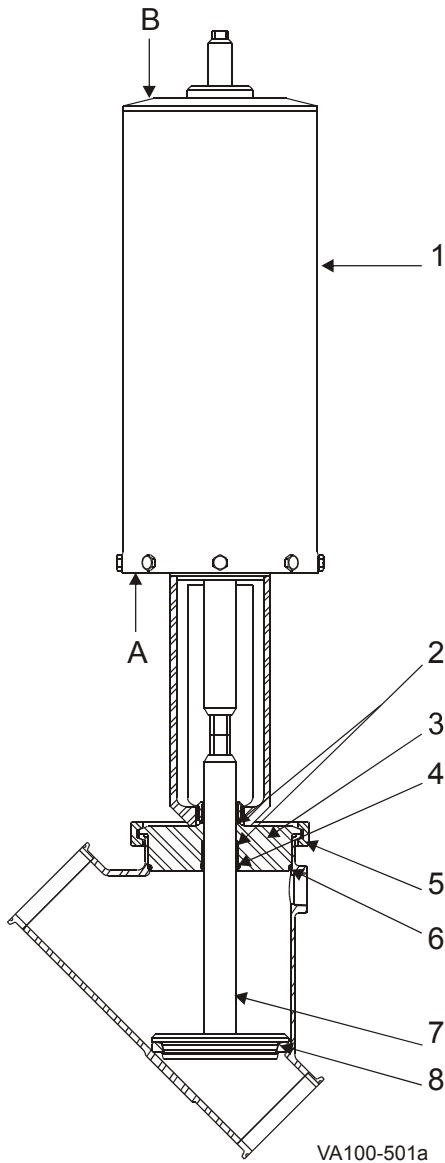

Figure 12: W61Y Shut Off Valve

Air-to-Raise Actuator

1. Apply air to Port A to raise the stem.
2. Remove the body clamp (Figure 10, item 5).
3. Release the air pressure.
4. Remove the body from the adapter (item 3). For two-piece bodies, un-clamp and remove the lower body first.
5. Shut off the air and disconnect the air line to the actuator.
6. For valves with control modules, disconnect/lockout the electrical power to the valve.
7. Using 5/8-inch wrench flats on the stem, unscrew and remove the valve stem (item 7).
8. Replace the seat ring (item 8) as needed. See "Seat Replacement" on page 37.
9. Unscrew the adapter (item 3) from the yoke.
10. Remove the body o-ring (item 6) and stem o-ring (item 4); replace them as needed.
11. Inspect and replace the PTFE bearing (item 2) as needed.

Air-to-Lower Actuator

1. Shut off the air and disconnect the air line to the actuator at Port B.
2. For valves with control modules, disconnect/lockout the electrical power to the valve.
3. Remove the body clamp (item 5) and body from the adapter (item 3). For two-piece bodies, un-clamp and remove the lower body first.
4. Using 5/8-inch wrench flats on the stem, unscrew and remove the valve stem (item 7).
5. Replace the seat ring (item 8) as needed. See "Seat Replacement" on page 37.
6. Unscrew the adapter (item 3) from the yoke.
7. Remove the body o-ring (item 6) and stem o-ring (item 4); replace them as needed.
8. Inspect and replace the PTFE bearing (item 2) as needed.

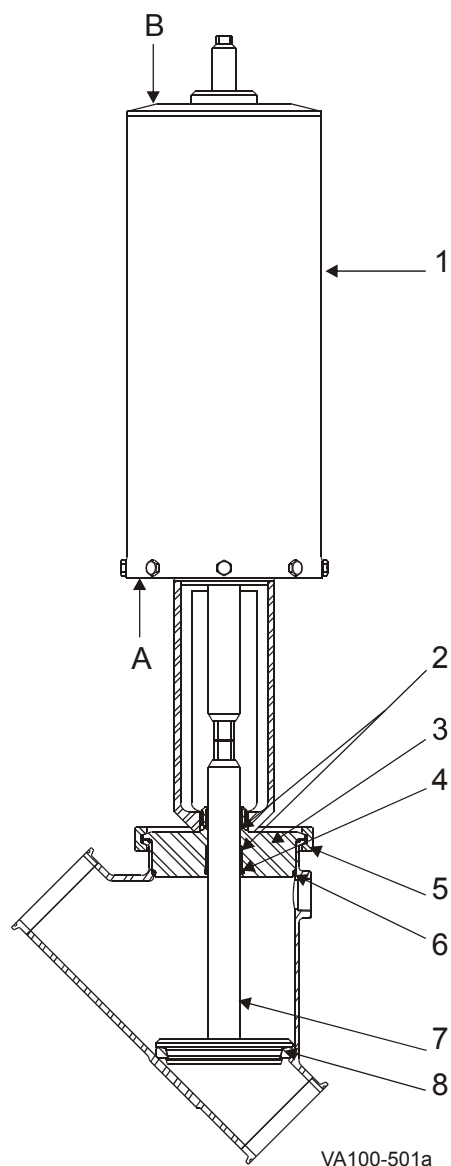
W61Y Valve Assembly**Figure 13: W61Y Shut Off Valve****Air-to-Raise Actuator**

1. Screw the adapter (Figure 11, item 3) onto the yoke.
2. Install the body o-ring (item 6), stem o-ring (item 4), and PTFE bearing (item 2).
3. Using 5/8-inch torque wrench flats on the stem, install the valve stem (item 7). Torque to 380 in/lbs.
4. Apply air to Port A to raise the stem.
5. Assemble the body to the adapter; secure it with the body clamp (item 5).
6. Release the air pressure.

Air-to-Lower Actuator

1. Screw the adapter (item 3) onto the yoke.
2. Install the body o-ring (item 6), stem o-ring (item 4), and PTFE bearing (item 2).
3. Using 5/8-inch torque wrench flats on the stem, install the valve stem (item 7). Torque to 380 in/lbs.
4. Assemble the body to the adapter; secure it with the body clamp (item 5).

W62/W82 Valve Disassembly

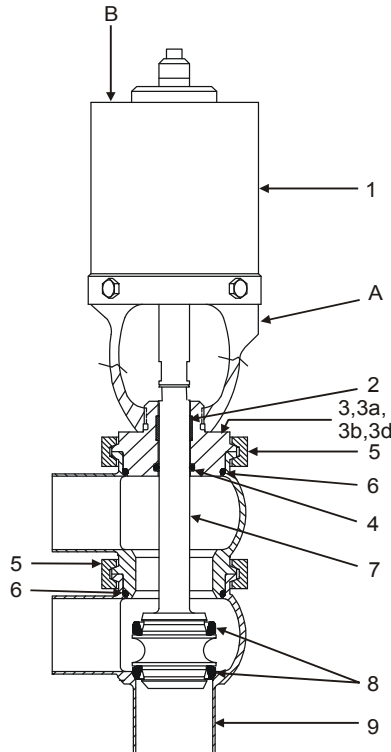

VA100-242b

**Figure 14: W62/W82 Divert Valve
(Air-to-Raise Shown)**

Air-to-Raise Actuator

1. Apply air to Port A to raise the stem.
2. Remove the lower body clamp (Figure 14, item 5) and lower body.
3. Shut off the air and disconnect the air line to the actuator.
4. For valves with control modules, disconnect/lockout the electrical power to the valve.
5. Using 5/8-inch wrench flats on the stem, unscrew and remove the valve stem (item 7).
6. Remove the upper body clamp (item 5) and upper body.
7. Replace the seat ring (item 8) as needed. See "Seat Replacement" on page 37.
8. Unscrew the adapter (item 3) from the yoke.
9. Remove the body o-ring (item 6) and stem o-ring (item 4); replace them as needed.
10. Inspect and replace the PTFE bearing (item 2) as needed.

Air-to-Lower Actuator

1. Remove the lower body clamp (Figure 14, item 5) and lower body (item 9).
2. Apply air to Port B to lower the stem.
3. Using 5/8-inch wrench flats on the stem, unscrew and remove the valve stem (item 7).
4. Shut off the air and disconnect the air line to the actuator.
5. Remove the upper body clamp (item 5) and upper body.
6. Replace the seat ring (item 8) as needed. See "Seat Replacement" on page 37.
7. Unscrew the adapter (item 3) from the yoke.
8. Remove the body o-ring (item 6) and stem o-ring (item 4); replace them as needed.
9. Inspect and replace the PTFE bearing (item 2) as needed.

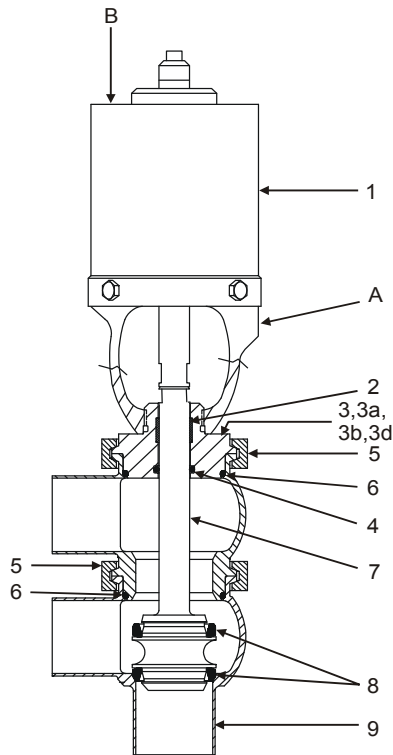
W62/W82 Valve Assembly

VA100-242b

**Figure 15: W62/W82 Divert Valve
(Air-to-Raise Shown)**

Air-to-Raise Actuator

1. Screw the adapter (Figure 15, item 3) onto the yoke.
2. Install the body o-ring (item 6), stem o-ring (item 4), and PTFE bearing (item 2).
3. Assemble the upper body to the adapter; secure it with the upper body clamp (item 5).
4. Using 5/8-inch torque wrench flats on the stem, install the valve stem (item 7). Torque to 380 in/lbs.
5. Apply air to Port A to raise the stem.
6. Install the lower body o-ring (item 6).
7. Assemble the lower body; secure it with the lower body clamp (item 5).
8. Release the air pressure.

Air-to-Lower Actuator

1. Screw the adapter (item 3) onto the yoke.
2. Install the body o-ring (item 6), stem o-ring (item 4), and PTFE bearing (item 2).
3. Assemble the upper body to the adapter; secure it with the upper body clamp (item 5).
4. Apply air to Port B to lower the stem.
5. Using 5/8-inch torque wrench flats on the stem, install the valve stem (item 7). Torque to 380 in/lbs.
6. Release the air pressure.
7. Install the lower body o-ring (item 6).
8. Assemble the lower body; secure it with the lower body clamp (item 5).

W63/W83 Valve Disassembly

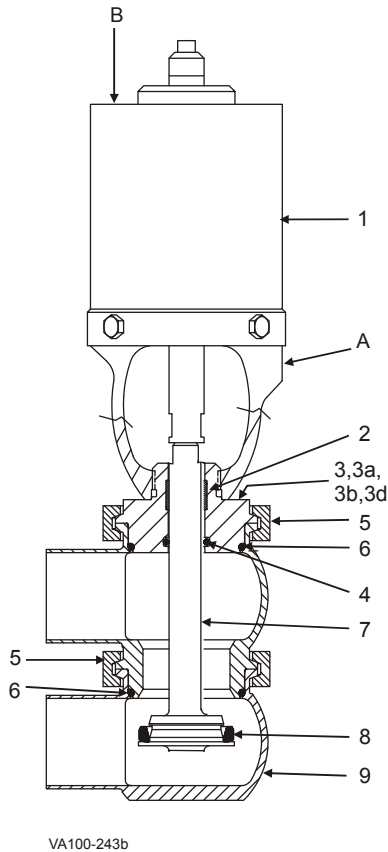

Figure 16: W63/W83 Shut Off Valve (Air-to-Raise Shown)

Air-to-Raise Actuator

1. Remove the lower body clamp (Figure 16, item 5) and the lower body (item 9).
2. Remove the body o-ring (item 6); replace as needed.
3. Shut off the air and disconnect the air line to the actuator.
4. For valves with control modules, disconnect/lockout the electrical power to the valve.
5. Using 5/8-inch wrench flats on the stem, unscrew and remove the valve stem (item 7).
6. Replace the seat ring (item 8) as needed. See "Seat Replacement" on page 37.
7. Remove the upper body clamp (item 5) and the upper body from the adapter (item 3).
8. Unscrew the adapter (item 3) from the yoke.
9. Remove the body o-ring (item 6) and stem o-ring (item 4); replace as needed.
10. Inspect and replace the PTFE bearing (item 2) as needed.

Air-to-Lower Actuator

1. Remove the lower body clamp (Figure 16, item 5) and the lower body (item 9).
2. Apply air to Port B to lower the stem.
3. Using 5/8-inch wrench flats on the stem, unscrew and remove the valve stem (item 7).
4. Release the air pressure.
5. Remove the upper body clamp (item 5) and the upper body from the adapter (item 3).
6. Unscrew the adapter (item 3) from the yoke.
7. Remove the body o-ring (item 6) and stem o-ring (item 4); replace as needed.

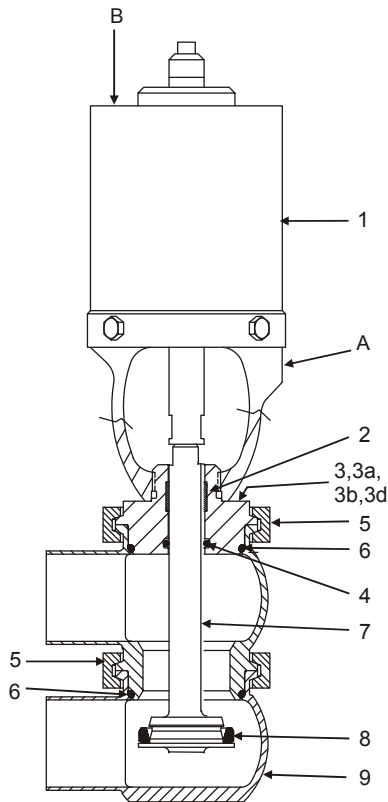
W63/W83 Valve Assembly**Air-to-Raise Actuator**

VA100-243b

**Figure 17: W63/W83 Shut Off Valve
(Air-to-Raise Shown)**

1. Screw the adapter (Figure 17, item 3) onto the yoke.
2. Install the body o-ring (item 6), stem o-ring (item 4) and PTFE bearing (item 2).
3. Assemble the upper body to the adapter; secure it with the upper body clamp (item 5).
4. Using 5/8-inch torque wrench flats on the stem, install the valve stem (item 7). Torque to 380 in/lbs.
5. Install the lower body o-ring (item 6).
6. Assemble the lower body; secure it with the lower body clamp (item 5).

Air-to-Lower Actuator

1. Screw the adapter (item 3) onto the yoke.
2. Install the body o-ring (item 6), stem o-ring (item 4) and PTFE bearing (item 2).
3. Assemble the upper body to the adapter; secure it with the upper body clamp (item 5).
4. Apply air to Port B to lower the stem.
5. Using 5/8-inch torque wrench flats on the stem, install the valve stem (item 7). Torque to 380 in/lbs.
6. Release the air pressure.
7. Install the lower body o-ring (item 6).
8. Assemble the lower body; secure it with the lower body clamp (item 5).

W64/W84 Valve Disassembly

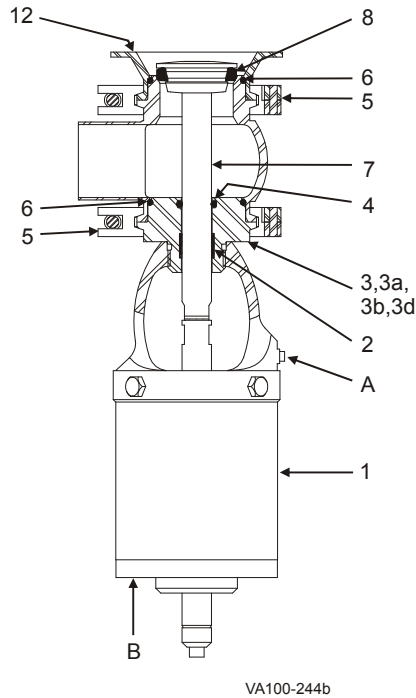

Figure 18: W64/W84 Tank Outlet Valve

Air-to-Raise Actuator

1. Shut off the air and disconnect the air line to the actuator.
2. For valves with control modules, disconnect/lockout the electrical power to the valve.
3. Remove the body/tank flange clamp (Figure 18, item 5) and remove the valve from the tank flange.
4. Using 5/8-inch wrench flats on the stem, unscrew and remove the valve stem (item 7).
5. Replace the seat ring (item 8) as needed. See "Seat Replacement" on page 37.
6. Remove the lower body o-ring (item 6); replace as needed.
7. Remove the upper body clamp (item 5) and upper body from the adapter (item 3).
8. Unscrew the adapter (item 3) from the yoke.
9. Remove the upper body o-ring (item 6) and stem o-ring (item 4); replace as needed.
10. Inspect and replace the PTFE bearing (item 2) as needed.

Air-to-Lower Actuator

1. Shut off the air and disconnect the air line to the actuator.
2. For valves with control modules, disconnect/lockout the electrical power to the valve.
3. Remove the body/tank flange clamp (Figure 18, item 5) and remove the valve from the tank flange.
4. Reapply the air to the actuator.
5. Using 5/8-inch wrench flats on the stem, unscrew and remove the valve stem (item 7).
6. Shut off the air and disconnect the air line to the actuator.
7. Remove the upper body clamp (item 5) and upper body from the adapter (item 3).
8. Unscrew the adapter (item 3) from the yoke.
9. Remove the upper body o-ring (item 6) and stem o-ring (item 4); replace as needed.

W64/W84 Valve Assembly

Figure 19: W64/W84 Tank Outlet Valve

Air-to-Raise Actuator

1. Screw the adapter (Figure 19, item 3) onto the yoke.
2. Install the body o-ring (item 6), stem o-ring (item 4), and PTFE bearing (item 2).
3. Assemble the upper body to the adapter; secure it with the upper body clamp (item 5).
4. Using 5/8-inch torque wrench flats on the stem, install the valve stem (item 7). Torque to 380 in/lbs.
5. Install the lower body o-ring (item 6) onto the body.
6. Insert the valve into the tank flange and tighten the body clamp (item 5).

Air-to-Lower Actuator

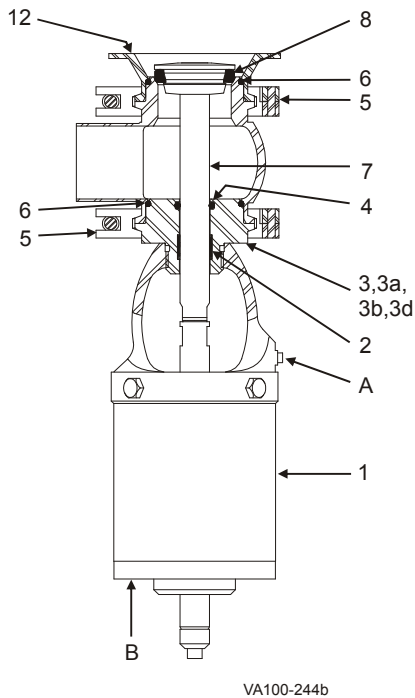
1. Screw the adapter (Figure 19, item 3) onto the yoke.
2. Install the body o-ring (item 6), stem o-ring (item 4), and PTFE bearing (item 2).
3. Assemble the upper body to the adapter; secure it with the upper body clamp (item 5).
4. Apply air to Port B to lower the stem.
5. Using 5/8-inch torque wrench flats on the stem, install the valve stem (item 7). Torque to 380 in/lbs.
6. Release the air pressure.
7. Install the lower body o-ring (item 6) onto the body.
8. Insert the valve into the tank flange and tighten the body clamp (item 5).

W64R/W84R Valve Disassembly

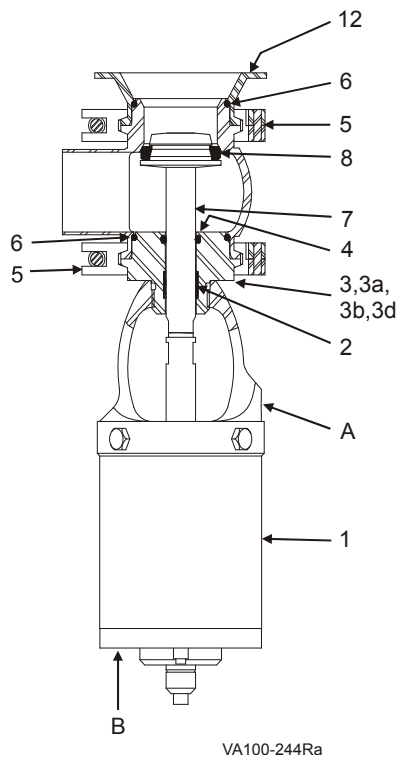

Figure 20: W64R/W84R Tank Outlet Valve

Air-to-Raise Actuator

1. Remove the body/tank flange clamp (item 5) and remove the valve from the tank flange.
2. Apply air to Port A to raise the stem.
3. Remove the body clamp (item 5).
4. Release the air pressure.
5. Remove the body from the adapter (item 3).
6. Shut off the air and disconnect the air line to the actuator.
7. For valves with control modules, disconnect/lockout the electrical power to the valve.
8. Using 5/8-inch wrench flats on the stem, unscrew and remove the valve stem (item 7).
9. Replace the seat ring (item 8) as needed. See "Seat Replacement" on page 37.
10. Unscrew the adapter (item 3) from the yoke.
11. Remove the body o-ring (item 6) and stem o-ring (item 4); replace as needed.
12. Inspect and replace the PTFE bearing (item 2) as needed.

Air-to-Lower Actuator

1. Remove the body/tank flange clamp (Figure 20, item 5) and remove the valve from the tank flange.
2. Shut off and disconnect the air line to the actuator.
3. For valves with control modules, disconnect/lockout the electrical power to the valve.
4. Remove the body clamp (item 5) and body from the adapter (item 3).
5. Using 5/8-inch wrench flats on the stem, unscrew and remove the valve stem (item 7).
6. Replace the seat ring (item 8) as needed. See "Seat Replacement" on page 37.
7. Unscrew the adapter (item 3) from the yoke.
8. Remove the body o-ring (item 6) and stem o-ring (item 4); replace as needed.
9. Inspect and replace the PTFE bearing (item 2) as needed.

W64R/W84R Valve Assembly

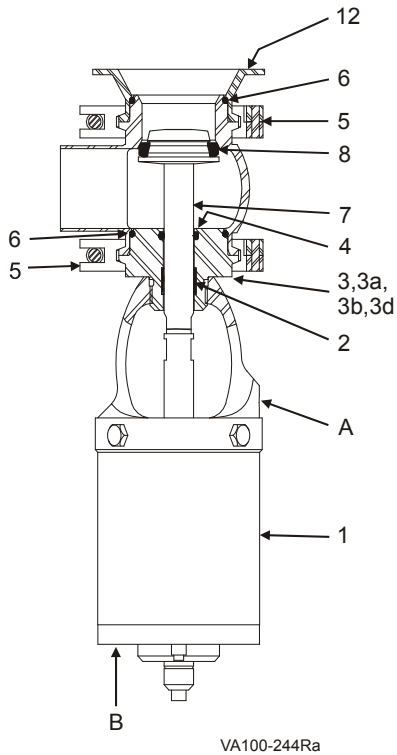

Figure 21: W64R/W84R Tank Outlet Valve

Air-to-Raise Actuator

1. Screw the adapter (Figure 21, item 3) onto the yoke.
2. Install the body o-ring (item 6), stem o-ring (item 4), and the PTFE bearing (item 2).
3. Using 5/8-inch torque wrench flats on the stem, install the valve stem (item 7). Torque to 380 in/lbs.
4. Apply the air to Port A to raise the stem.
5. Assemble the body to the adapter (item 3); secure it with the body clamp (item 5).
6. Release the air pressure.
7. Insert the valve into the tank flange and tighten the body clamp (item 5).

Air-to-Lower Actuator

1. Screw the adapter (item 3) onto the yoke.
2. Install the body o-ring (item 6), stem o-ring (item 4), and the PTFE bearing (item 2).
3. Using 5/8-inch torque wrench flats on the stem, install the valve stem (item 7). Torque to 380 in/lbs.
4. Assemble the body to the adapter (item 3); secure it with the body clamp (item 5).
5. Insert the valve into the tank flange and tighten the body clamp (item 5).

W64ET/W84ET Valve Disassembly

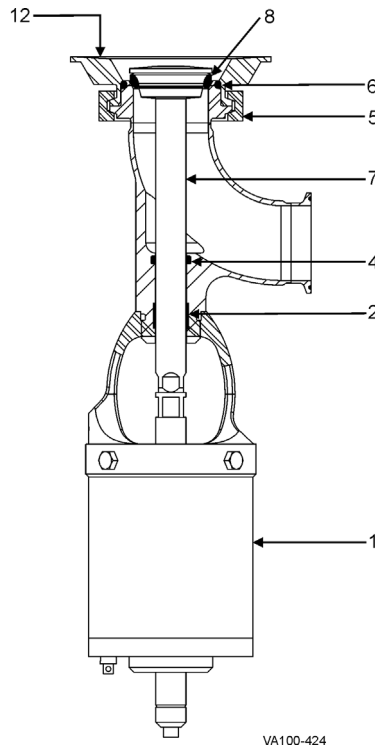

Figure 22: W64ET Tank Outlet Valve

Air-to-Raise Actuator

1. Shut off the air and disconnect the air line to the actuator.
2. For valves with control modules, disconnect/lockout the electrical power to the valve.
3. Remove the body/tank flange clamp (Figure 22, item 5) and remove the valve from the tank flange.
4. Using 5/8-inch wrench flats on the stem, unscrew and remove the valve stem (item 7).
5. Replace the seat ring (item 8) as needed. See "Seat Replacement" on page 37.
6. Remove the lower body o-ring (item 6); replace as needed.
7. Unscrew the body from the yoke.
8. Remove the stem o-ring (item 4); replace as needed.
9. Inspect and replace the PTFE bearing (item 2) as needed.

Air-to-Lower Actuator

1. Shut off the air and disconnect the air line to the actuator.
2. For valves with control modules, disconnect/lockout the electrical power to the valve.
3. Remove the body/tank flange clamp (Figure 22, item 5) and remove the valve from the tank flange.
4. Reapply the air to the actuator.
5. Using 5/8-inch wrench flats on the stem, unscrew and remove the valve stem (item 7).
6. Shut off the air and disconnect the air line to the actuator.
7. Unscrew the body from the yoke.
8. Remove the stem o-ring (item 4); replace as needed.
9. Inspect and replace the PTFE bearing (item 2) as needed.

W64ET/W84ET Valve Assembly

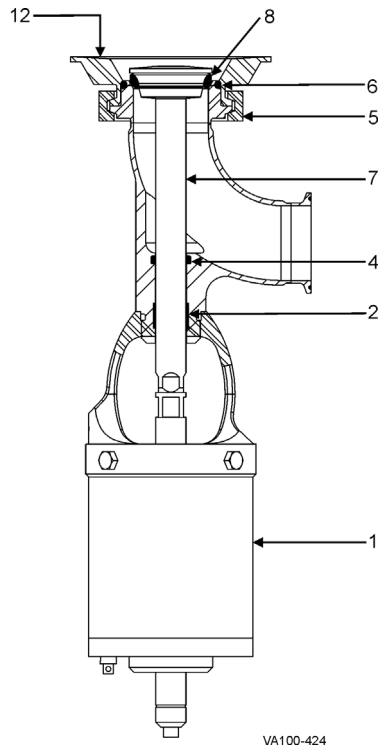

Figure 23: W64ET Tank Outlet Valve

Air-to-Raise Actuator

1. Screw the body onto the yoke.
2. Install the stem o-ring (Figure 23, item 4) and PTFE bearing (item 2).
3. Using 5/8-inch torque wrench flats on the stem, install the valve stem (item 7). Torque to 380 in/lbs.
4. Install the lower body o-ring (item 6) onto the body.
5. Insert the valve into the tank flange and tighten the body clamp (item 5).

Air-to-Lower Actuator

1. Screw the body onto the yoke.
2. Install the stem o-ring (item 4) and PTFE bearing (item 2).
3. Apply air to Port B to lower the stem.
4. Using 5/8-inch torque wrench flats on the stem, install the valve stem (item 7). Torque to 380 in/lbs.
5. Release the air pressure.
6. Install the lower body o-ring (item 6) onto the body.
7. Insert the valve into the tank flange and tighten the body clamp (item 5).

W65/W85 Valve Disassembly

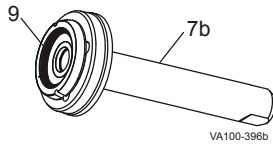

Figure 24 - Remove Counter bore O-ring

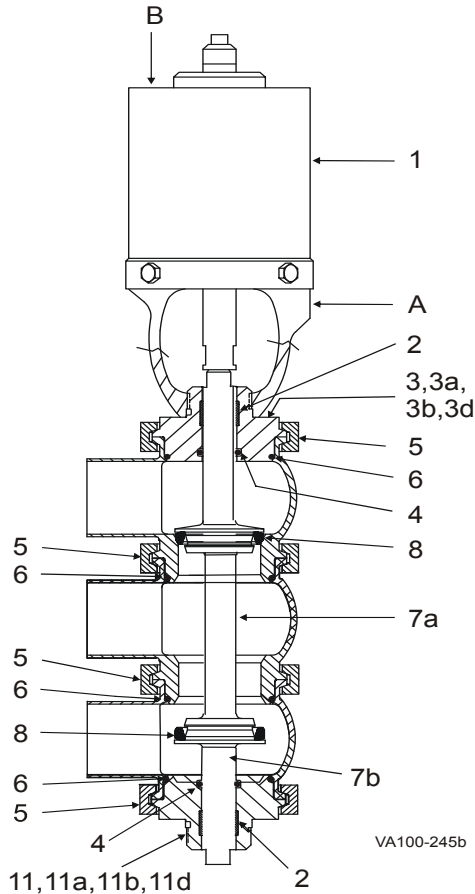

Figure 25: W65/W85 Divert Valve

Air-to-Raise Actuator

1. Remove the lower body clamp (Figure 25, item 5) and the lower body.
2. Remove the body o-ring (item 6); replace as needed.
3. If necessary, remove the lower bearing carrier (item 11) from the lower body.
4. Remove the body o-ring (item 6) and stem o-ring (item 4) from the bearing carrier; replace as needed.
5. Inspect and replace the PTFE bearing (item 2) as needed.
6. Using 5/8-inch wrench flats on the stem, unscrew and remove the lower valve stem (Figure 25, item 7b).
7. Replace the o-ring (Figure 24, item 9) in the counter bore of the lower stem as needed.
8. Replace the lower seat ring (Figure 25, item 8) as needed. See "Seat Replacement" on page 37.
9. Remove the middle body clamp (item 5) and the middle body.
10. Remove the middle body o-ring (item 6); replace as needed.
11. Apply air to Port A to raise the stem.
12. Remove the upper body clamp (item 5) and the upper body from the adapter (item 3).
13. Using 5/8-inch wrench flats on the stem, unscrew and remove the upper valve stem (item 7a).
14. Replace the seat ring (item 8) as needed. See "Seat Replacement" on page 37.
15. Unscrew the adapter (item 3) from the yoke.
16. Remove the body o-ring (item 6) and stem o-ring (item 4) from the adapter; replace as needed.
17. Inspect and replace the PTFE bearing (item 2) as needed.

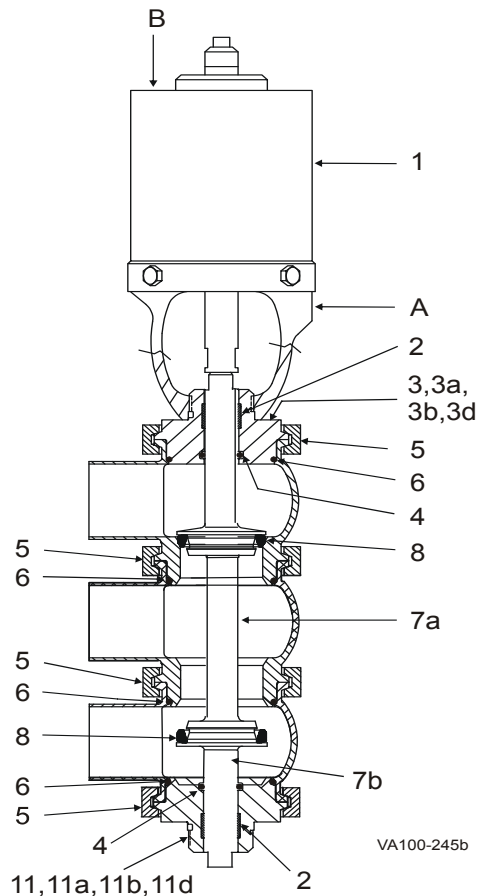

Figure 26: W65/W85 Divert Valve

Air-to-Lower Actuator

1. Remove the lower body clamp (Figure 25, item 5) and the lower body.
2. Remove the body o-ring (item 6); replace as needed.
3. If necessary, remove the lower bearing carrier (item 11) from the lower body.
4. Remove the body o-ring (item 6) and stem o-ring (item 4) from the bearing carrier; replace as needed.
5. Inspect and replace the PTFE bearing (item 2) as needed.
6. Apply air to Port B to lower the stem.
7. Using 5/8-inch wrench flats on the stem, unscrew and remove the lower valve stem (Figure 25, item 7b).
8. Replace the o-ring (Figure 25, item 9) in the counter bore of the lower stem as needed.
9. Replace the lower seat ring (Figure 25, item 8) as needed. See "Seat Replacement" on page 37.
10. Release the air pressure.
11. Shut off the air and disconnect the air line to the actuator.
12. For valves with control modules, disconnect/lockout the electrical power to the valve.
13. Remove the middle body clamp (item 5) and the middle body.
14. Remove the middle body o-ring (item 6); replace as needed.
15. Remove the upper body clamp (item 5) and the upper body from the adapter (item 3).
16. Using 5/8-inch wrench flats on the stem, unscrew and remove the upper valve stem (item 7a).
17. Replace the seat ring (item 8) as needed. See "Seat Replacement" on page 37.
18. Unscrew the adapter (item 3) from the yoke.
19. Remove the body o-ring (item 6) and stem o-ring (item 4) from the adapter; replace as needed.
20. Inspect and replace the PTFE bearing (item 2) as needed.

W65/W85 Valve Assembly

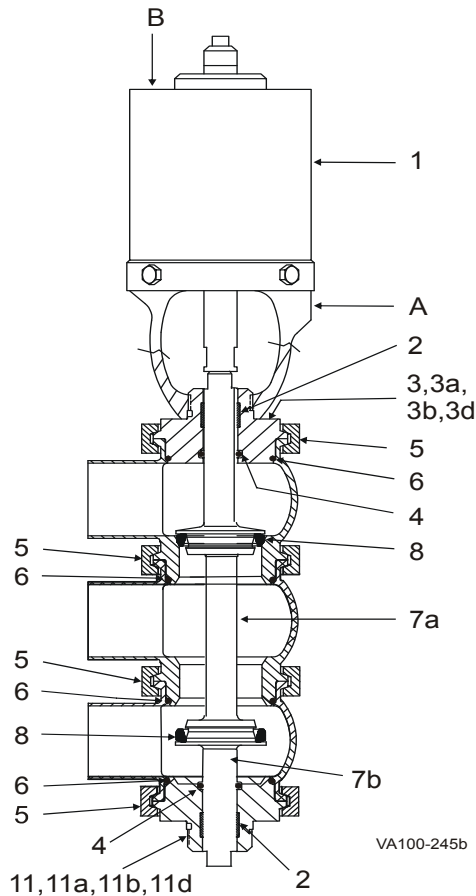

Figure 27: W65/W85 Divert Valve

Air-to-Raise Actuator

1. Screw the adapter (Figure 25, item 3) onto the yoke.
2. Install the upper body o-ring (item 6) onto the adapter.
3. Using 5/8-inch torque wrench flats on the stem, install the upper valve stem (item 7a). Torque to 380 in/lbs.
4. Apply air to Port A to raise the stem.
5. Assemble the upper body to the adapter; secure it with the upper body clamp (item 5).
6. Install the middle body o-ring (item 6) onto the upper body.
7. Assemble the middle body; secure it with the middle body clamp (item 5).
8. Release the air pressure.
9. Using 5/8-inch torque wrench flats on the stem in the yoke area, install the lower valve stem (item 7b) onto the upper stem (item 7a). Torque to 380 in/lbs.
10. Install the lower body o-ring (item 6) on the middle body.
11. Assemble the lower body; secure it with the lower body clamp (item 5).
12. Install the body o-ring (item 6) onto the bearing carrier and insert it into the lower body.
13. Install the bearing carrier clamp (item 5).

Air-to-Lower Actuator

1. Screw the adapter (Figure 25, item 3) onto the yoke.
2. Install the upper body o-ring (item 6) onto the adapter.
3. Using 5/8-inch torque wrench flats on the stem, install the upper valve stem (item 7a). Torque to 380 in/lbs.
4. Assemble the upper body to the adapter; secure it with the upper body clamp (item 5).
5. Install the middle body o-ring (item 6) onto the upper body.
6. Assemble the middle body; secure it with the middle body clamp (item 5).
7. Apply air to Port B to lower the stem.
8. Install the o-ring (item 9) in the counter bore of the lower stem (item 7b).
9. Using 5/8-inch torque wrench flats on the stem in the yoke area, install the lower valve stem (item 7b). Torque to 380 in/lbs.
10. Install the lower body o-ring (item 6) on the middle body.
11. Assemble the lower body; secure it with the lower body clamp (item 5).
12. Release the air pressure.
13. Install the body o-ring (item 6) onto the bearing carrier (item 11) and insert it into the lower body.
14. Install the bearing carrier clamp (item 5).

Seat Replacement

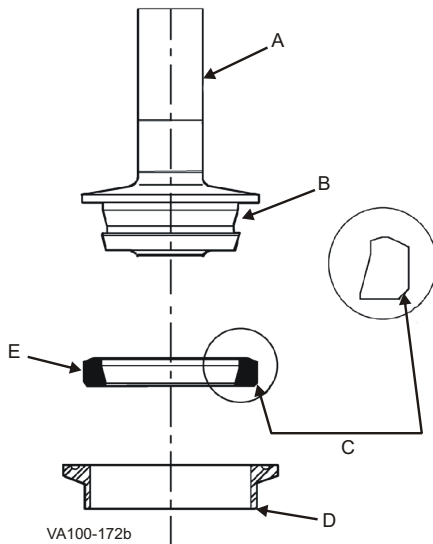

Figure 28: Tef-Flow™ Seat

A. Stem	C. Seat Angle
B. Stem Groove	D. "S" Clamp Ferrule
E. Seat Ring	

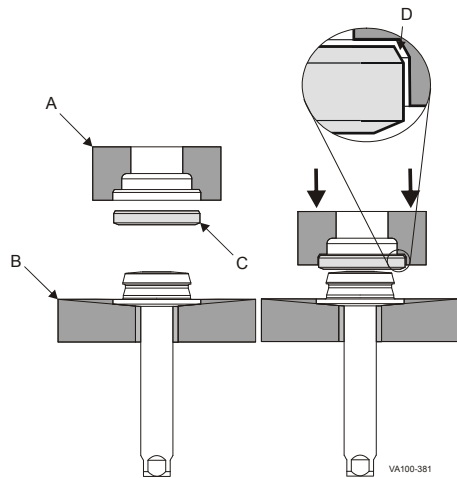

Figure 29: Tef-Flow™ P Seat

Standard Tef-Flow™ Seat

Standard Tef-Flow™ seats are white and can be cut for removal.

1. Place a piece of shim stock or a feeler gauge behind the seat ring (Figure 28, item C) to prevent scratching the stem surface.
2. Carefully cut through the seat ring with a utility knife.
3. Remove the seat ring (item C) from the stem (item A).
4. To install a new seat, place the seat ring on a standard S-Line ferrule (item D) equal in size to the valve, or on the seat ring tool as shown in Figure 28, item E.
5. Align the stem on the seat ring and apply pressure to snap the seat into place.
6. The valve seat will spin freely when properly installed.

Tef-Flow™ P Seat

Tef-Flow™ P seats are gray and must be melted through for proper removal.

1. Melt through the seat ring using a clean plastic cutting tip on a heavy-duty soldering iron capable of maintaining a 700°F (371°C) tip temperature.



CAUTION: Do not use a knife to cut the seat ring from the stem to avoid personal injury and/or damage to the stem.

2. To install a new seat, place the installation tool base onto a table or bench with a 1.0" (25 mm) hole (Figure 28, item B). For tool part numbers, see "Installation Tools" on page 85.
3. Place the stem through the hole in the base.
4. Place a new seat ring (item C) onto the stem with the seat angle (item D) and flat side facing away from the base as shown in Figure 28.
5. Place the seat ring tool (Figure 28, item A) over the seat ring. For tool part numbers, see "Installation Tools" on page 85.
6. Using an arbor press, apply a constant steady pressure to the seat ring tool, snapping the seat ring into place.



CAUTION: DO NOT use a hammer to install.

7. The valve seat will spin freely when properly installed.

Standard Tri Ring Seat

1. Remove the Tri Ring seat by carefully cutting or using an o-ring tool or pick to pull the seat out of the groove. Do not scratch or nick the metal seating surface.
2. Clean the Tri Ring groove after removing the seat.
3. Lubricate the new Tri Ring (Figure 28, item A) with acceptable cleansing solution or lubricant.
4. Place the stem through a 1-1/8 inch (30 mm) hole bored through a board, or secure it with a vise with copper or aluminum jaws.
5. Start the Tri Ring as shown in Figure 29.
6. Using the installation tool, part number 102797+ (Figure 29, item B), press the Tri Ring into the plug at locations A, B, C, and D (Figure 30). If this tool is not available, a dull, flat tool can be used. DO NOT use a knife or any other sharp item that will tear or cut the Tri Ring.
7. To finish installation, press small sections of the seal, alternating from side to side (A-B-C-D), avoiding large loops of seal.
8. When properly installed, the Tri Ring seat lip will protrude slightly from the seat edge as shown in Figure 29.

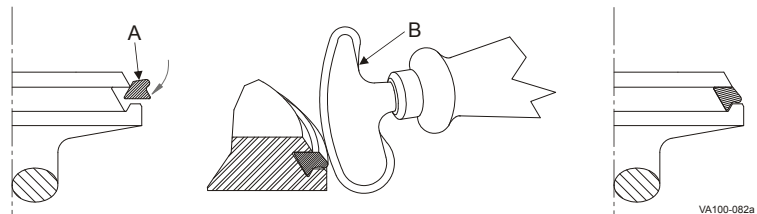

Figure 30: Installing New Tri Ring Seat

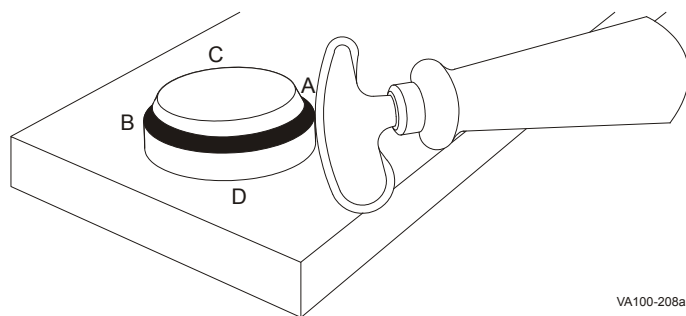

Figure 31: Pressing Tri Ring Into Plug

Bonded Seat Stems

Bonded seat stems do not require maintenance. If the seating surface becomes damaged, purchase a new seat stem.

Metal Seat Stems

Metal seat stems do not require maintenance. If the seating surface becomes damaged, purchase a new seat stem. Do not attempt to re-lap or machine the seating surfaces.

Servicing Actuators: U-cups, O-rings and Bearings

Shut off the air and disconnect the air supply line to the actuator. Disconnect/lockout the electrical power to the valve.

Valves with Control Module

For control top information, please refer to publication 95-03083. For additional product information, please see our website at spxflow.com/en/waukesha-cherry-burrell/resources/product-literature/.

For the Set and Forget Switch option, remove the target on the indicator stem before removing the actuator can.

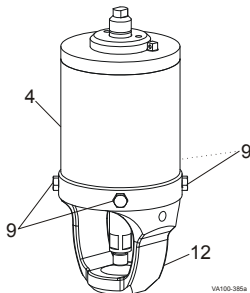

Figure 32: Remove Yoke

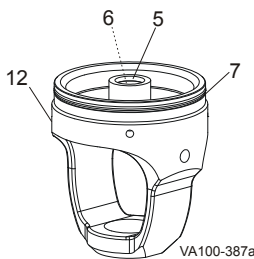

Figure 33: Remove Yoke O-ring and Guide Bearing

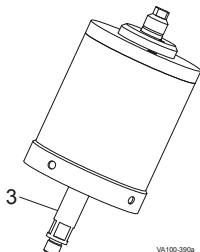

Figure 34: Pull Lower Stem

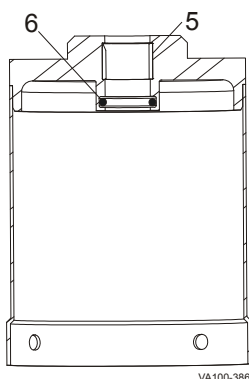

Figure 35: Remove O-ring and Bearing

O-ring and Bearing Replacement: 4", 5" and 6" Actuator

1. Remove the cap screws (Figure 32, item 9) and pull the yoke (item 12) from the actuator cylinder (item 4).
2. Remove the yoke (Figure 33, item 4). Inspect the lower stem o-ring (item 6) and cylinder o-ring seals (item 7).
3. Remove the worn o-ring seals. Coat the new o-ring seals with Dow Corning® #7 Silicone Lubricant or equivalent, and replace them.
4. Remove the PTFE guide bearing (Figure 33, item 5) by placing a screwdriver behind the bearing to pry it away from the wall of the yoke. Use needle-nose pliers to grip and remove the bearing.
5. Pull the lower stem (Figure 34, item 3) to remove the caged spring assembly from the actuator cylinder.



DANGER: Do not use air to remove the caged spring assembly.

6. Remove and inspect the upper stem o-ring (Figure 35, item 6) in the top of the actuator cylinder.
7. Remove the worn o-ring seals. Coat the new o-ring seals with Dow Corning® #7 Silicone Lubricant or equivalent, and replace them.
8. Inspect and replace the PTFE guide bearing (Figure 35, item 5) in the actuator cylinder as needed.

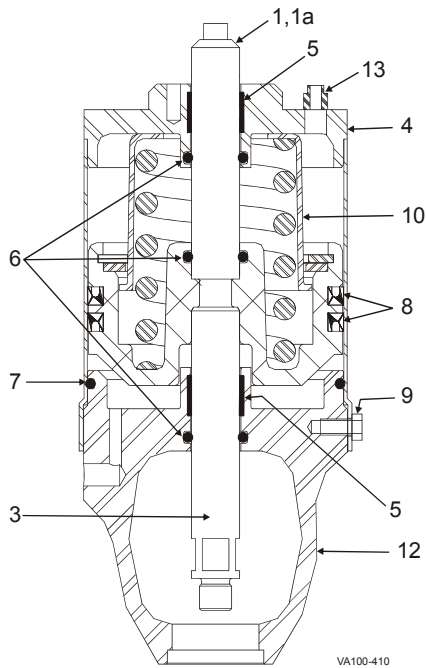

Figure 36: 4" and 5" Actuator

U-cup Replacement: 4" and 5" Actuator

1. Inspect the piston U-cup seal (Figure 36, item 8).
2. Remove the worn U-cup seal. Do not score or nick grooves in the piston (item 10).
3. Coat the new U-cup seal with Dow Corning® #7 Silicone Lubricant or equivalent.
4. Slightly stretch the lubricated seal to fit over the piston. Install the lower seal first with the "U" pointing down. Install the upper seal with the "U" pointing up. U-cup seals flare slightly at the outer edges when they are properly installed.
5. Place the piston and spring assembly in the cylinder.
6. Place the cylinder over the yoke, and install cap screws (item 9) to secure it.

NOTE: If the stems were disassembled during this maintenance procedure, clean, prime, and apply Loctite® 2440 Thread Locker, according to manufacturer's specifications, to the upper (items 1, 1a) and lower (item 3) stems. Torque the stems to 200 in/lbs.

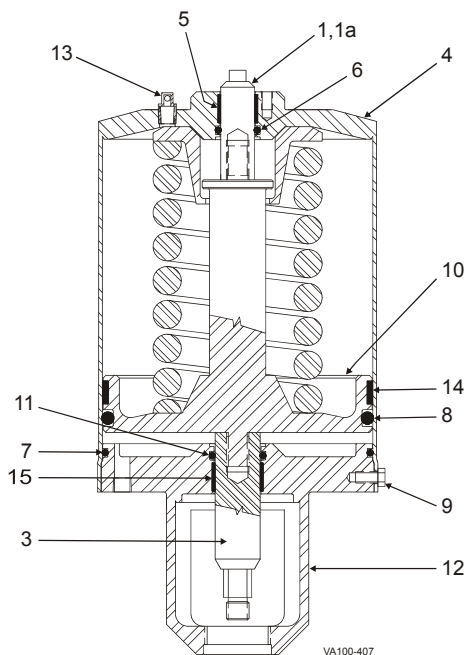

Figure 37: 6" Actuator

O-ring and Bearing Replacement: 6" Actuator

1. Inspect the piston o-ring seal (Figure 37, item 8).
2. Remove the worn o-ring seal. Do not score or nick grooves in the piston (item 10).
3. Coat the new o-ring seal with Dow Corning® #7 Silicone Lubricant or equivalent.
4. Slightly stretch the lubricated seal to fit over the piston.
5. Inspect and replace the PTFE guide bearing (item 14) on the piston as needed.
6. Place the piston and spring assembly in the cylinder.
7. Place the cylinder over the yoke, and install cap screws (item 9) to secure it.

NOTE: If the stems were disassembled during this maintenance procedure, clean, prime, and apply Loctite® 2440 Thread Locker, according to manufacturer's specifications, to the upper (items 1, 1a) and lower (item 3) stems. Torque the stems to 400 in/lbs.

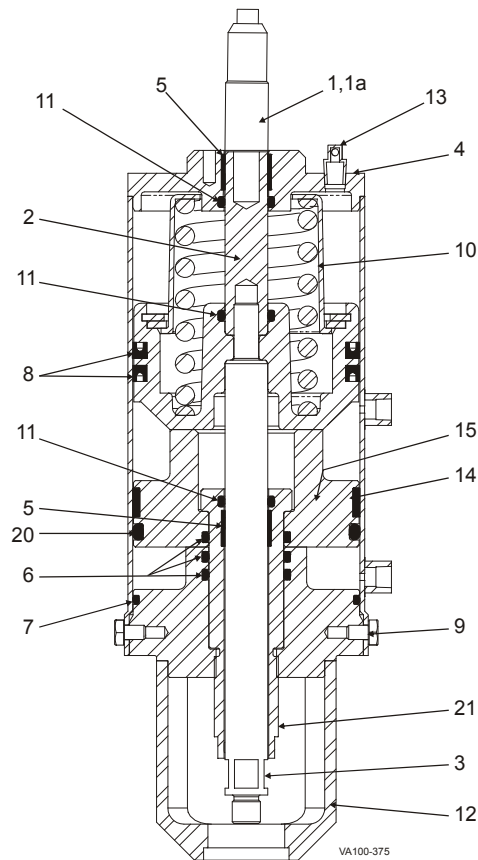

Figure 38: 4" Air-to-Raise 3-Position Actuator

U-cup, O-ring and Bearing Replacement: 4" Air-to-Raise 3-Position Actuator

1. Inspect the upper piston U-cup seal (Figure 38, item 8).
2. Remove the worn U-cup seal. Do not score or nick grooves in the piston (item 10).
3. Coat the new U-cup seal with Dow Corning® #7 Silicone Lubricant or equivalent.
4. Slightly stretch the lubricated seal to fit over the upper piston. Install the lower seal first with the "U" pointing down. Install the upper seal with the "U" pointing up. U-cup seals flare slightly at the outer edges when properly installed.
5. Inspect the lower piston o-ring (item 20), stem o-ring (items 6 and 11) and yoke o-ring seals (item 7).
6. Remove the worn o-ring seals. Do not score or nick grooves in the piston (item 15).
7. Coat the new o-ring seals with Dow Corning® #7 Silicone Lubricant or equivalent.
8. Slightly stretch the lubricated piston seal to fit over the lower piston.
9. Inspect and replace the PTFE guide bearings (items 14 and 5) as needed.
10. Place the outer stem (item 21) in the lower piston.
11. Screw the outer stem into the yoke (item 12).
17 turns = full stroke adjustment
1 turn = 0.063 stroke

Using a spanner wrench, turn the stem counter-clockwise for more stroke and clockwise for less stroke.
12. Place the piston and spring assembly in the cylinder.
13. Place the cylinder over the yoke, and install cap screws (item 9) to secure it.

NOTE: If the stems were disassembled during this maintenance procedure, clean, prime, and apply Loctite® 2440 Thread Locker, according to manufacturer's specifications, to the upper (items 1, 1a) and lower (item 3) stems. Torque the stems to 200 in/lbs.

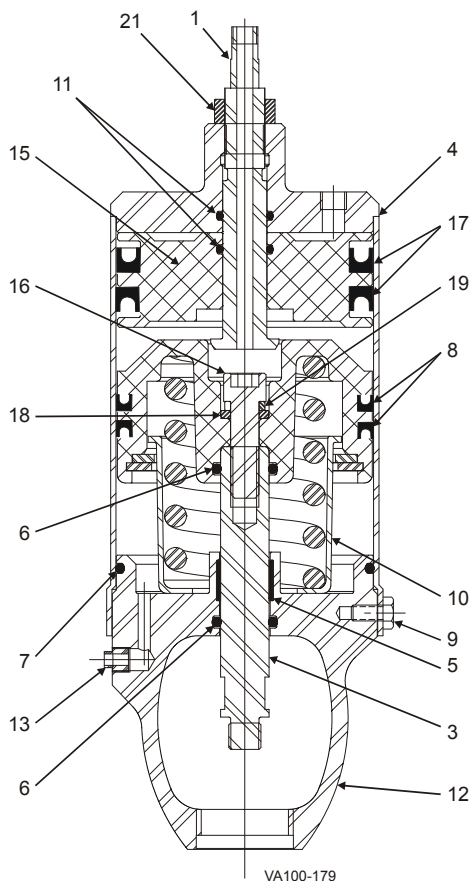
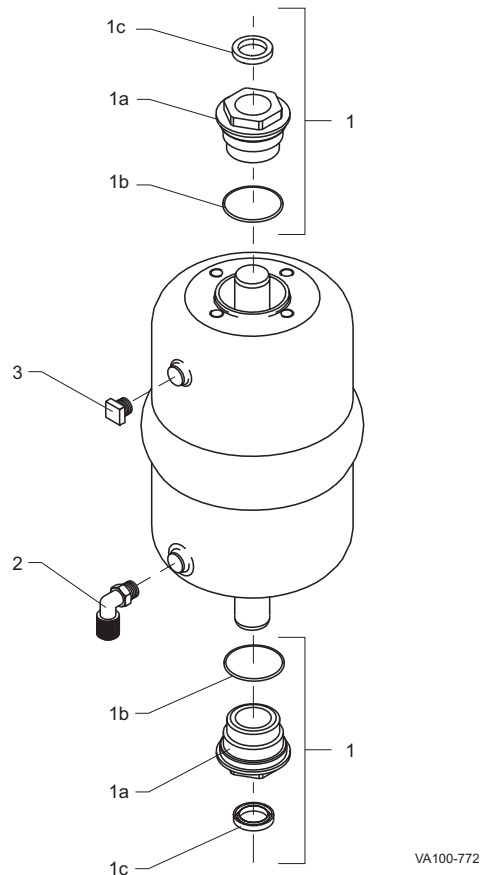

Figure 39: 4" Air-to-Lower 3-Position Actuator

U-cup, O-ring and Bearing Replacement: 4" Air-to-Lower 3-Position Actuator

1. Inspect the lower piston U-cup seal (Figure 39, item 8).
2. Remove the worn U-cup seal. Do not score or nick grooves in the piston (item 10).
3. Coat the new U-cup seal with Dow Corning® #7 Silicone Lubricant or equivalent.
4. Slightly stretch the lubricated seal to fit over the lower piston. Install the lower seal first with "U" pointing down. Install the upper seal with the "U" pointing up. U-cup seals flare slightly at the outer edges when properly installed.
5. Inspect the stem o-ring seal (item 6).
6. Remove the worn o-ring seal. Do not score or nick grooves in the piston.
7. Coat the new o-ring seal with Dow Corning® #7 Silicone Lubricant or equivalent.
8. Slightly stretch the lubricated seal to fit over the lower piston.
9. Inspect and replace the PTFE guide bearing (item 5) on the piston as needed.
10. Connect the piston and spring assembly to the stem (item 3) with the bolt (item 16).
11. Assemble the piston and spring assembly to the yoke (item 12).
12. Inspect the upper piston U-cup seal (item 17).
13. Remove the worn U-cup seal. Do not score or nick grooves in the piston (item 15).
14. Coat the new U-cup seal with Dow Corning® #7 Silicone Lubricant or equivalent.
15. Slightly stretch the lubricated seal to fit over the upper piston. Install the lower seal first with the "U" pointing down. Install the upper seal with the "U" pointing up. U-cup seals flare slightly at the outer edges when properly installed.
16. Inspect the upper stem o-ring seal (item 11).
17. Remove the worn o-ring seal. Do not score or nick grooves in the cylinder top and upper piston.
18. Coat the new o-ring seal with Dow Corning® #7 Silicone Lubricant or equivalent.
19. Install the lubricated seal in the upper piston and cylinder top.
20. Assemble the upper piston and stem (item 1) to the cylinder. Secure them with a hex nut (item 21). Place the cylinder over the yoke, and install cap screws (item 9) to secure it.
21. Adjust the mid-position by loosening the hex nut (item 21) and turning the stem (item 1).

NOTE: If the stems were disassembled during this maintenance procedure, clean, prime, and apply Loctite® 2440 Thread Locker, according to manufacturer's specifications, to the upper (item 1) and lower (item 3) stems. Torque the stems to 200 in/lbs.



O-ring and Bearing Replacement: Maintenance-Free Actuator

1. Remove the actuator from the valve assembly:
 - a. Remove the control top.
 - b. Remove the retaining nut and spacer located on top of the actuator.
 - c. Unclamp the valve body and remove the body and stem.
 - d. Un-bolt the yoke from the bottom of the actuator assembly.

2. Remove the o-ring guide nut assembly (Figure 40, item 1) from both ends of the actuator.

3. Replace the bearing (item 1c) and o-ring (1b).

NOTE: Apply a thick layer of silicone lubricant on the o-ring prior to installation.

4. Re-install the o-ring guide nut assembly (Figure 40, item 1) and tighten the guide nut (item 1a) until it is snug.

NOTE: Do not over-tighten the nut ("snug" is all that is required).

5. Reassemble the valve in reverse order of the items in step 1 above.

Figure 40: Maintenance-Free Actuator

O-ring and Bearing Replacement: 4", 5" and 6" Adjustable-Spring Actuator

Adjustable-spring actuators are fully welded and cannot be disassembled or reversed. Only compressed air side seals and bearings require maintenance.



WARNING: Adjustable-Spring actuators cannot be disassembled. Do not attempt to cut the actuator or otherwise disassemble it, as the compressed spring will present a projectile hazard.



WARNING: For Adjustable-Spring actuators, unload the spring adjustment completely before attempting to service the actuator.

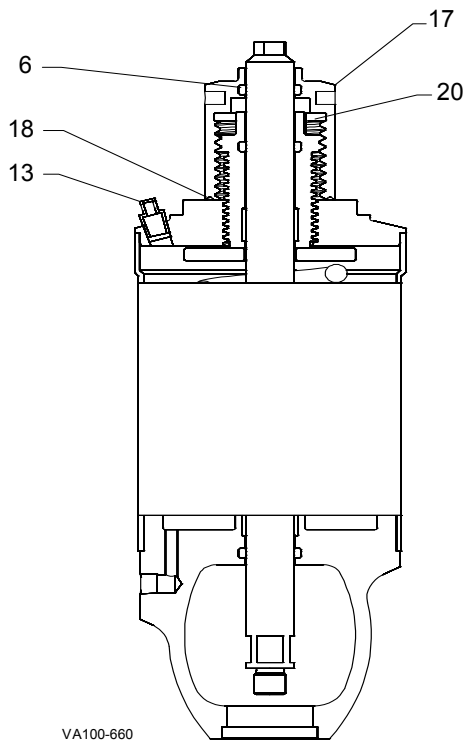

Figure 41: 4", 5" and 6" Air-to-Raise, Adjustable-Spring Actuator

NOTE: On the 6" design, the location of items 11 and 15 is reversed (see inset).

Air-to-Raise, Adjustable-Spring Actuator

1. Remove the valve from the body.
2. Shut off the air and disconnect the air supply line to the actuator.
3. Disconnect/lockout the electrical power to the valve.
4. Unscrew and remove the locknut cover (Figure 41, item 17). Unscrew and remove the adjustment screw (item 20). Check for free movement of the stem to ensure that no compression remains.
5. Inspect the o-ring (item 6) in the adjustment screw (item 20). Remove the worn o-ring seals. Coat the new o-ring seals with Dow Corning® #7 Silicone Lubricant or equivalent, and replace them.
6. Remove the PTFE guide bearing (item 5) in the adjustment screw by placing a screwdriver behind the bearing to pry it away from the wall of the yoke (item 12). Use needle-nose pliers to grip and remove the bearing.
7. Using wrenches on the upper and lower wrench flats, unscrew and remove the lower stem (item 3). **Do not remove the upper stem (item 1), as it locates an internal support washer.**
8. Remove and inspect the yoke area stem o-ring (item 11). Remove the worn o-ring seal. Coat the new o-ring seals with Dow Corning® #7 Silicone Lubricant or equivalent, and replace them.
9. Inspect and replace the PTFE guide bearing (item 15) in the yoke as needed.
10. Reassemble the actuator in reverse order.
11. Once secure, screw in the adjustment screw (item 20) until it is held by threads (not in its final position). Refer to Adjustable-Spring Actuators: Pressure Setting (Table 2 on page 17) for setting it to the desired loading pressure.

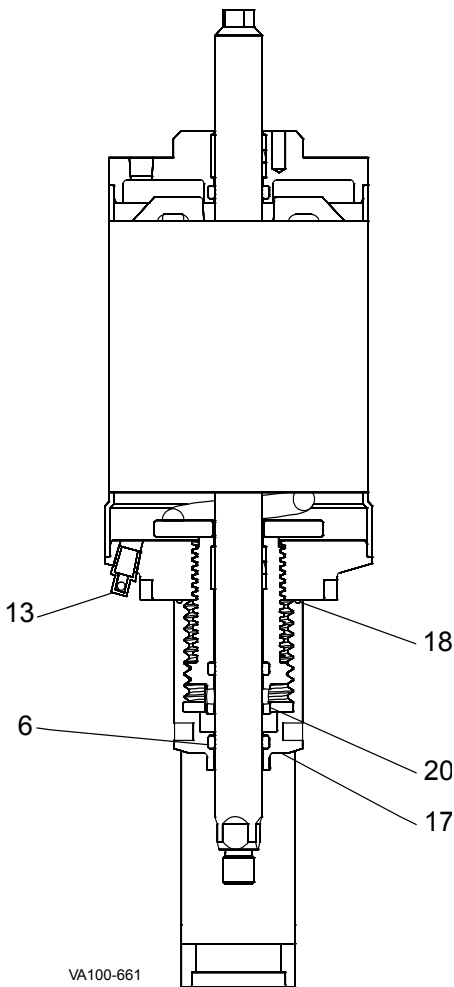

Figure 42: 4", 5" and 6" Air-to-Lower, Adjustable-Spring Actuator

Air-to-Lower, Adjustable-Spring Actuator

1. Remove the valve from the body.
2. Shut off the air and disconnect the air supply line to the actuator.
3. Disconnect/lockout the electrical power to the valve.



WARNING: For Adjustable-Spring actuators, unload the spring adjustment completely before attempting to service the actuator.

4. Using wrenches on the upper and lower wrench flats, unscrew and remove the upper stem (Figure 42, item 1). **Do not remove the lower stem (item 3) as it locates an internal support washer.**
5. Remove and inspect the indicator area stem o-ring (item 6). Remove the worn o-ring seal. Coat the new o-ring seals with Dow Corning® #7 Silicone Lubricant or equivalent, and replace them.
6. Inspect and replace the PTFE guide bearing (item 5) in the indicator area as needed.
7. Reassemble the actuator in reverse order.
8. Once secure, screw in the adjustment screw (item 20) until it is held by threads (not in its final position). Refer to Adjustable-Spring Actuators: Pressure Setting (Table 3 on page 17) for setting it to the desired loading pressure.

Reversing the Spring Action on the Maintenance-Free Actuator



1. Remove the control top (if applicable).
2. Loosen and remove the retaining nut and spacer from the stem on the top of the actuator.
3. Loosen and remove the bolts on the yoke that are threaded into the bottom of the actuator.
4. Lift the actuator cylinder from the yoke/stem.
5. Flip the actuator cylinder over and re-insert the stem into the actuator.
6. Re-install the yoke bolts on the bottom of the actuator.
7. Install the spacer and retaining nut on top of the actuator.
8. Install the control top (if applicable).

Figure 43: Maintenance-Free Actuator - reversing spring action

Reversing the Spring Action on the Maintainable Actuator

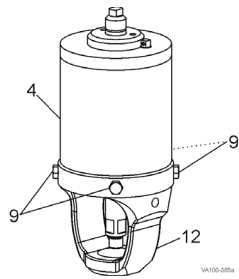

Figure 44:
Remove Yoke

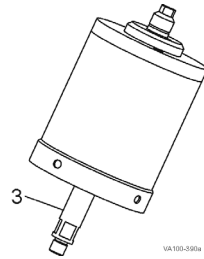
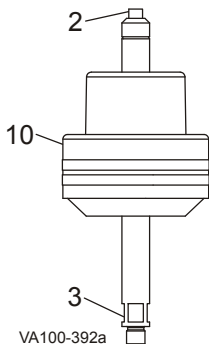
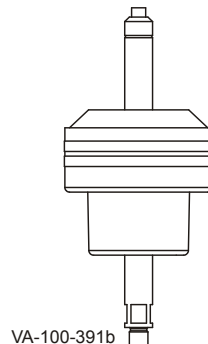

Figure 45: Pull Lower Stem



Air-to-Raise
Figure 46:
Remove Actuator Stem Halves



Air-to-Lower
Figure 47:
Actuator Piston/Spring Configuration

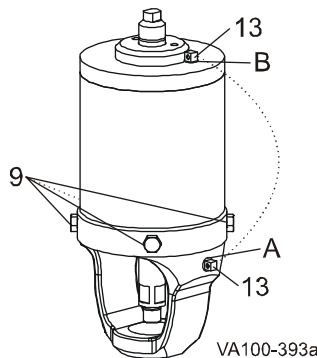

Figure 48: Cap Screws and Vent Plug

1. Remove the cap screws (Figure 44, item 9) and pull the yoke (item 12) from the actuator cylinder (item 4).
2. Pull the lower stem (Figure 45, item 3) to remove the caged spring assembly from the actuator cylinder.
3. Using a 5/8-inch wrench on the lower stem (Figure 46, item 3) and a 3/8-inch wrench on the upper stem (item 2), unscrew and remove the two actuator stem halves.
4. Turn the piston/spring assembly (item 10) over.
5. Install the actuator stem halves in the piston/spring assembly. See Figure 46 for Air-to-Raise configuration; Figure 47 for Air-to-Lower configuration.

Clean, prime and apply Loctite® 2440 Thread Locker, according to manufacturer's specifications, to the upper (items 1, 1a) and lower (item 3) stems (See Figure 36 and Figure 37 on page 40). Torque the stems to 200 in/lbs for 4" and 5" actuators; 400 in/lbs for 6" actuators.

6. Coat the U-cup and o-ring seals with Dow Corning® #7 Silicone Lubricant or equivalent.
7. Install the piston/spring assembly in the actuator cylinder and assemble them with cap screws (Figure 48, item 9).
8. Reverse the vent plug (Figure 48, item 13) as follows:

Air-to-Raise Actuator: The vent plug must be located on TOP of the actuator in Port B (Figure 48, item B).

Air-to-Lower Actuator: The vent plug must be located on the SIDE of the yoke in Port A (Figure 48, item A).

Parts Lists

W61/W81 Shutoff Valve

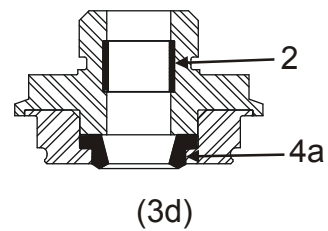
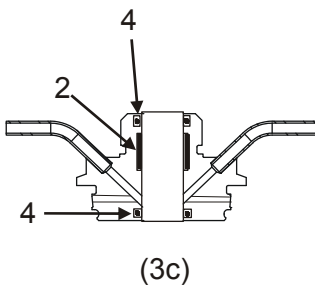
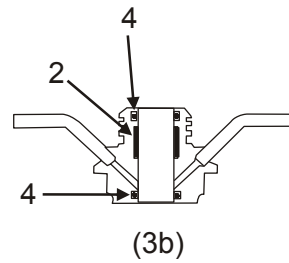
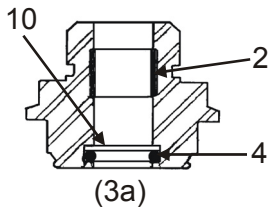
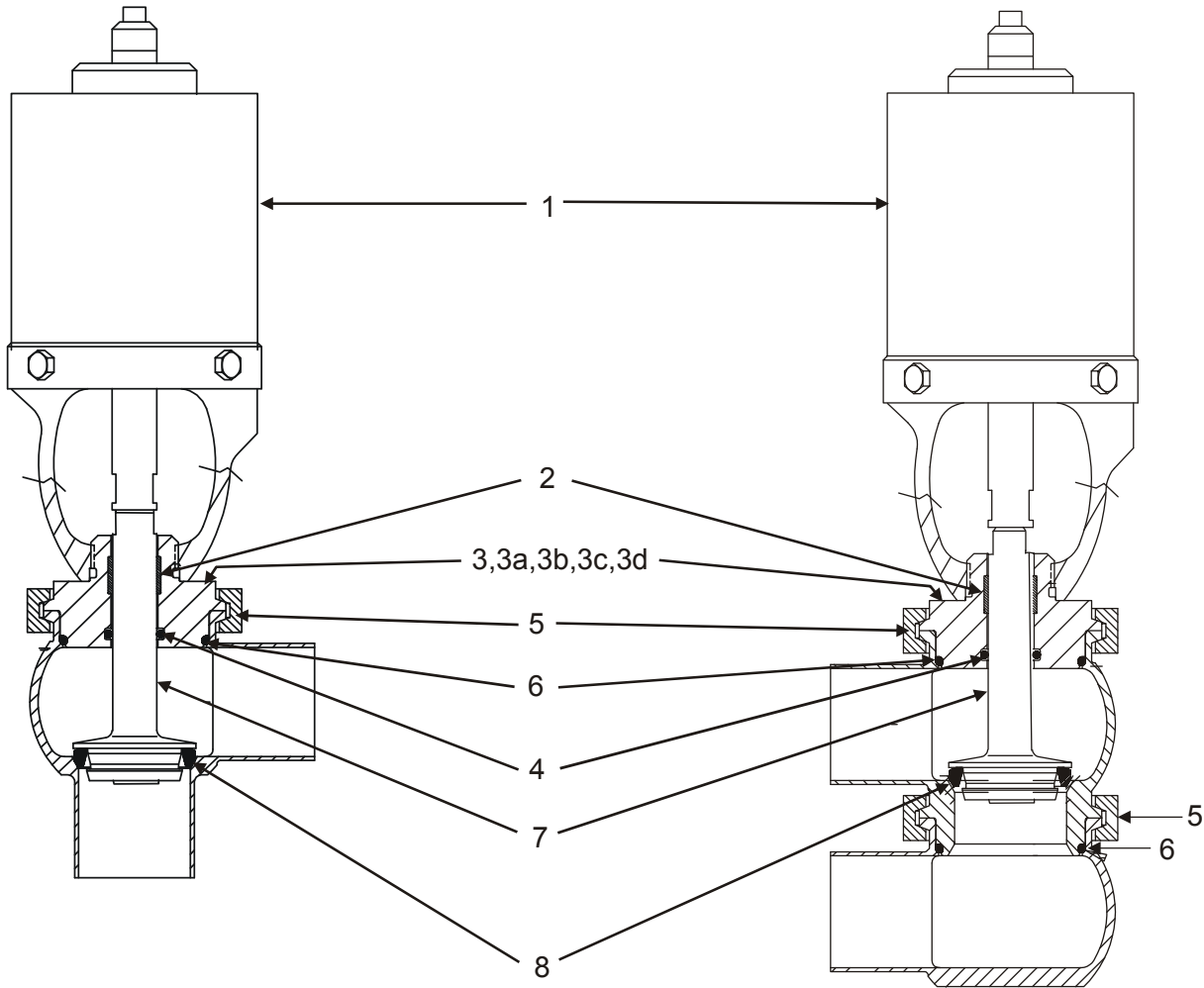

VA100-241

W61/W81 Shutoff Valve

Item #	Part Description	1" 25 mm	1-1/2" 40 mm	2" 50 mm	2-1/2" 65 mm	3" 80 mm	4" 100 mm	6" 150 mm	Notes
	Control Top	Contact Factory							
1	Actuator	See actuator parts list							
* 2	Bearing	102757+						106047+	
3	Adapter, W60 (Std.)	102406+	102407+	102408+	102409+	102410+	113822+		
3a	Adapter, W60 High Press. W80	109293+	109294+	109295+	POA				
		116925+	116926+	116927+	POA				
3b	Adapter, W80	106291+	106292+	106293+	106294+	106295+	114306+	2	
3c	Adapter, W81A	117785+	117786+	117787+	117788+	117789+	POA	3	
3d	Adapter, Wiping Stem Seal	117879+	117880+	117881+	117882+	117883+	POA	1	
* 4	O-ring EPDM	E70210						E70214	
	FKM	V70210						V70214	
* 4a	Wiping Stem Seal EPDM	116183+						POA	1
	FKM	115626+						POA	
5	Clamp Standard	119-30	119-33	119-34	119-51	119-87	113827+		
	High Pressure	119-271	119-272	119-273	POA			4	
* 6	O-ring, Body EPDM	E70223	E70228	E70232	E70236	E70244	E70258	5	
	FKM	V70223	V70228	V70232	V70236	V70244	V70258		
7	Stem (less seat ring)	Tef-Flow™ 102411+	102412+	102413+	102414+	102415+	102416+	N/A	
	Tri Ring	108130+	108131+	108132+	107045+	108134+	108135+	113823+	
	Metal	106386+	106387+	106388+	106389+	106390+	106391+	P.O.A	
* 8	Seat Ring Tef-Flow™	20-240	20-241	20-242	20-243	20-244	POA		
	Tef-Flow™ P	115347+	115348+	115349+	115350+	115351+	POA		
	Tri Ring, EPDM	107692+	107695+	107048+	102488+	107698+	102738+		
	Tri Ring, FKM	107983+	107986+	107982+	107974+	107989+	108020+		
10	High Pressure Backup Ring	BURT210			POA				

Notes

PL5027-CH1

* Recommended Spare Parts

1. Wiping Stem Seal Adapter and Wiping Stem Seal options available for W60 Series valves only.
2. W80 Adapter allows for liquid or steam flush of stem o-ring only.
3. W81A Adapter allows for liquid or steam flush of stem o-ring and body o-ring. Only available on one-piece body configurations.
4. High Pressure Body Clamp only required for valves equipped with High Pressure Adapter (item 3a).
5. W81A Adapter requires two body o-rings.

POA: Contact Factory

W61Y Shutoff Valve

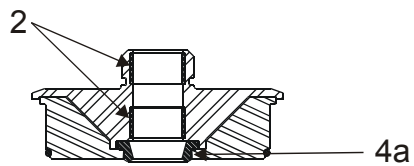
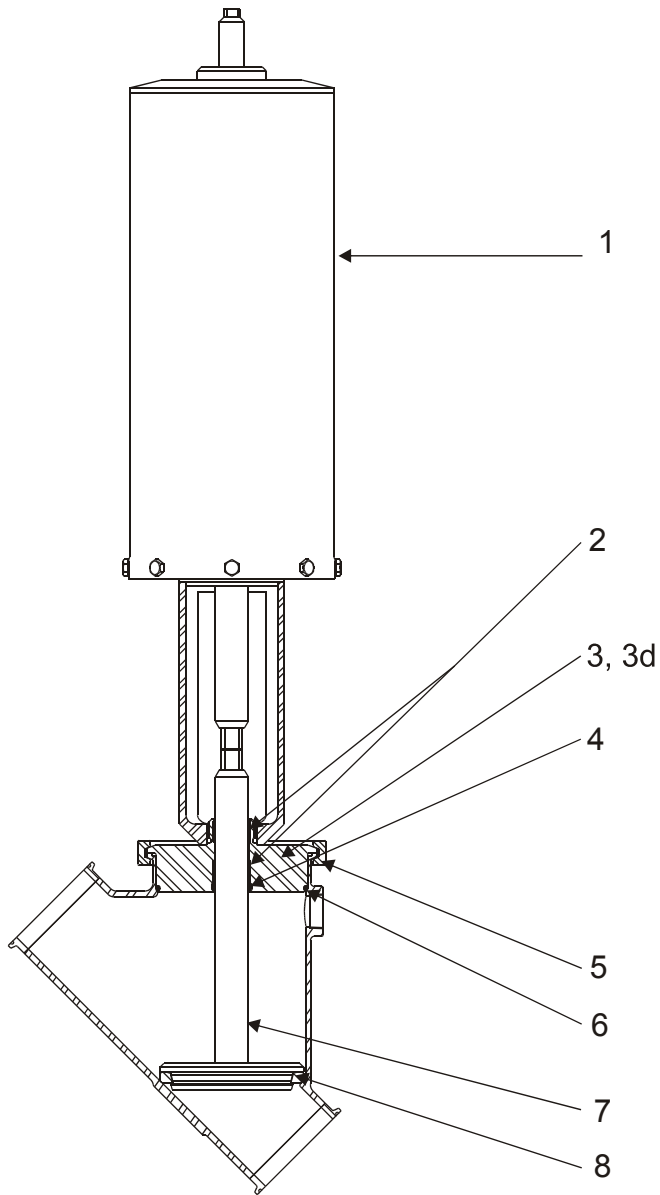

(3d)

VA100-501

W61Y Shutoff Valve

Item #	Part Description	2-1/2"	3"	4"	
1	Actuator	See actuator parts list			
* 2	Bearing	106047+			
3	Adapter, W60 (Std.)	119617+	119618+	119619+	
3d	Adapter, Wiping Stem Seal	122002+	122003+	122004+	
* 4	O-ring	EPDM	E70214		
		FKM	V70214		
* 4a	Wiping Stem Seal	EPDM	116184+		
		FKM	116185+		
5	Clamp	Standard	119-87	119-87	113827+
* 6	O-ring, Body	EPDM	E70241	E70244	E70257
		FKM	V70241	V70244	V70257
7	Stem (less seat ring)	Tef-Flow™	118479+	118480+	118481+
	O-Ring		127012+	127011+	127013+
* 8	Seat Ring	Tef-Flow™ P	118476+	118477+	118478+
	O-Ring	EPDM	E80336	E80344	E80356
		FKM	V80336	V80344	V80356

PL5027-CH2

* Recommended Spare Parts

W62/W82 Divert Valve

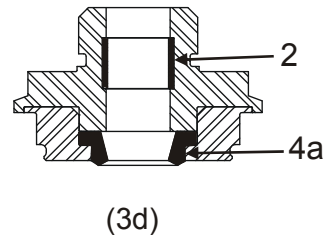
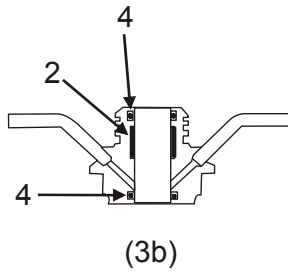
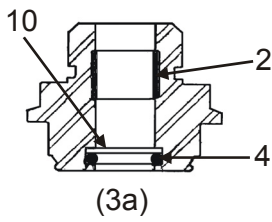
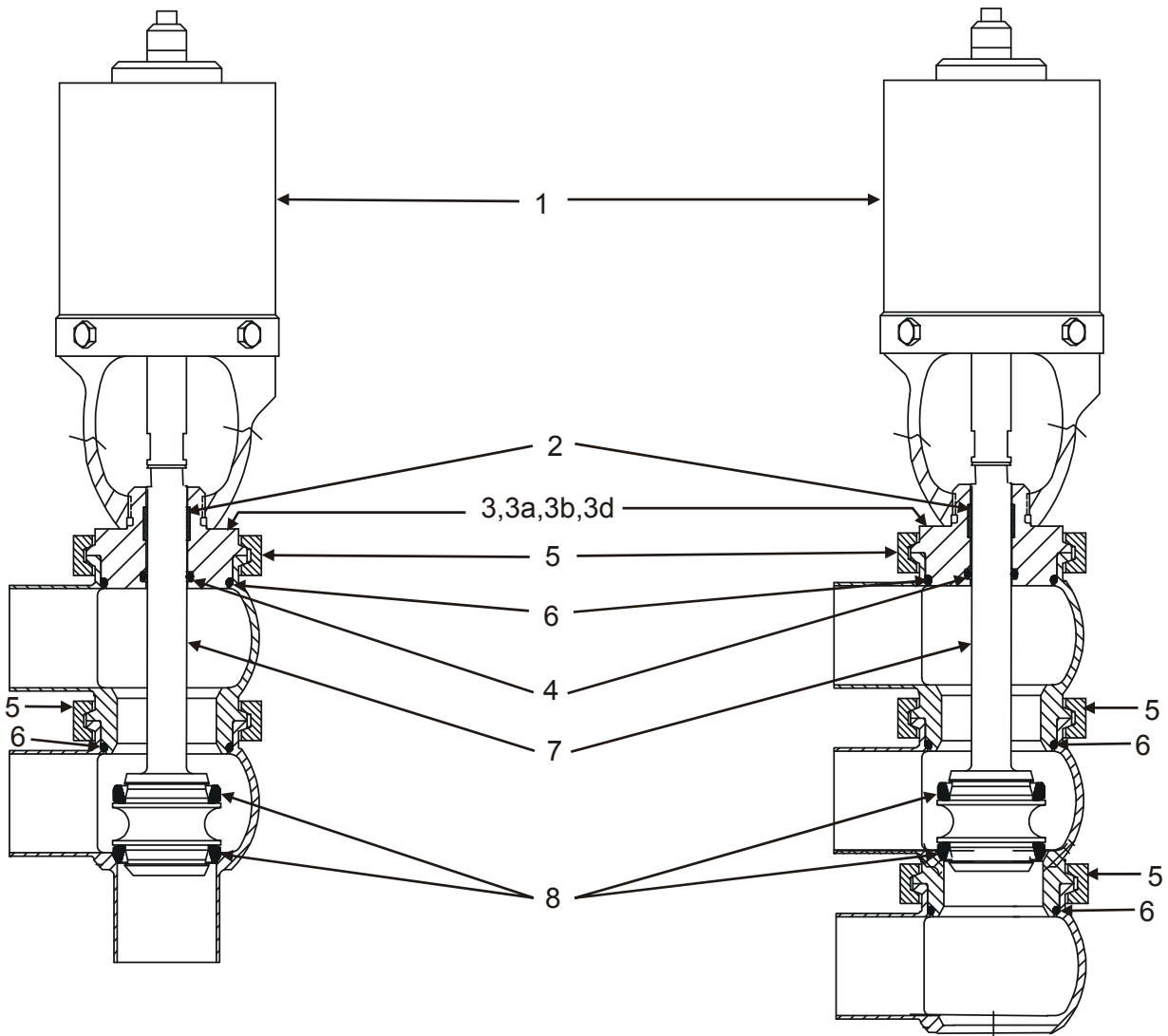

VA100-242

W62/W82 Divert Valve

Item #	Part Description	1" 25 mm	1-1/2" 40 mm	2" 50 mm	2-1/2" 65 mm	3" 80 mm	4" 100 mm	Notes
	Control Top	Contact Factory						
1	Actuator	See actuator parts list						
* 2	Bearing	102757+						
3	Adapter, W60 (Std.)	102406+	102407+	102408+	102409+	102410+		
3a	Adapter, High Pressure	W60 109293+	W80 116925+	109294+	109295+	116926+	116927+	N/A N/A
3b	Adapter, W80	106291+	106292+	106293+	106294+	106295+	2	
3d	Adapter, Wiping Stem Seal	117879+	117880+	117881+	117882+	117883+	1	
* 4	O-ring	EPDM	E70210					
		FKM	V70210					
* 4a	Wiping Stem Seal	EPDM	116183+					1
		FKM	115626+					
5	Clamp	Standard 119-30	119-33	119-34	119-51	119-87		
		High Pressure 119-271	119-272	119-273	N/A		3	
* 6	O-ring, Body	EPDM	E70223	E70228	E70232	E70236	E70244	
		FKM	V70223	V70228	V70232	V70236	V70244	
7	Stem (less seat ring)	Tef-Flow™ 102423+	102424+	102425+	102426+	102427+	102428+	
		Tef-Flow™ Long Stroke N/A	N/A	N/A	110966+	110935+	110937+	
		Tri Ring 108154+	108155+	108156+	108157+	108158+	108159+	
		Tri Ring, Long Stroke N/A	N/A	N/A	110983+	110984+	110985+	
		Metal 106392+	106393+	106394+	106395+	106396+	106397+	
		Metal, Long Stroke N/A	N/A	N/A	110998+	110999+	111000+	
* 8	Seat Ring	Tef-Flow™	20-240	20-241	20-242	20-243	20-244	
		Tef-Flow™ P	115347+	115348+	115349+	115350+	115351+	
		Tri Ring, EPDM	107692+	107695+	107048+	102488+	107698+	
		Tri Ring, FKM	107983+	107986+	107982+	107974+	107989+	
10	High Pressure Backup Ring	BURT210				N/A		

PL5027-CH3

*** Recommended Spare Parts**

1. Wiping Stem Seal Adapter and Wiping Stem Seal options available for W60 Series valves only.
2. W80 Adapter allows for liquid or steam flush of stem o-ring only.
3. High Pressure Body Clamp only required for valves equipped with High Pressure Adapter (item 3a).

W63/W83 Reverse Shutoff Valve

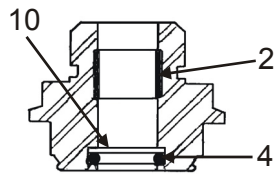
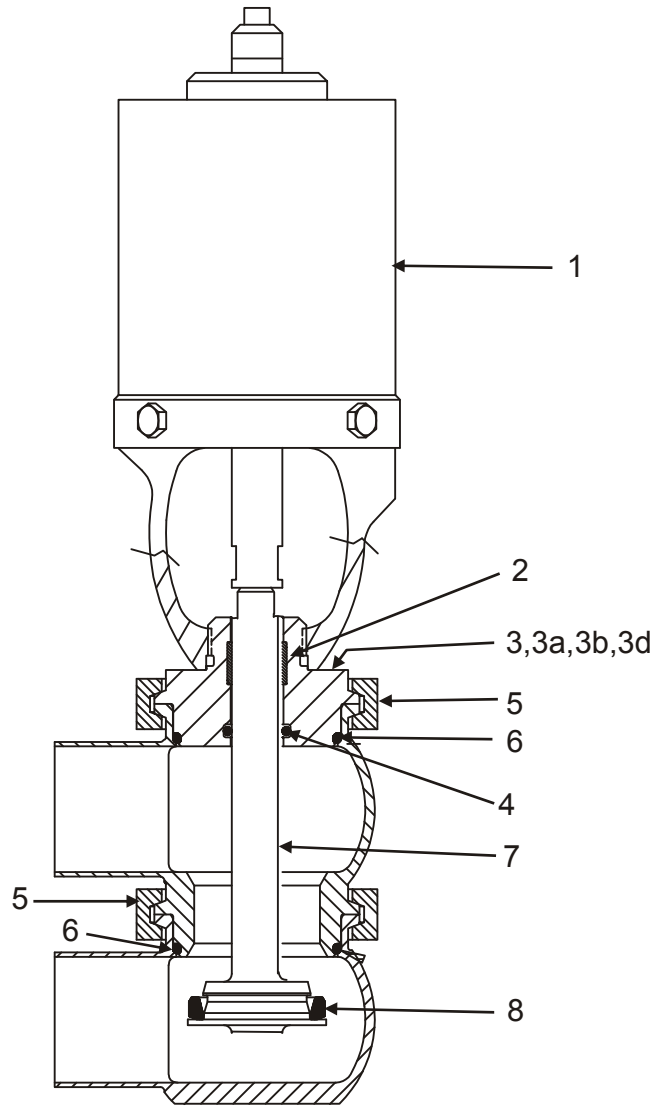

(3a)

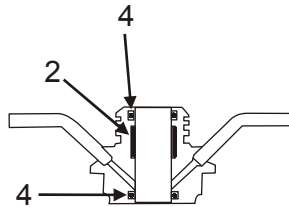

(3b)

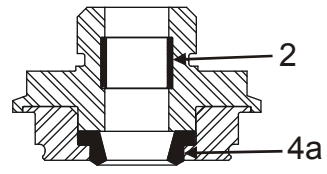

(3d)

VA100-243

W63/W83 Reverse Shutoff Valve

Item #	Part Description	1" 25 mm	1-1/2" 40 mm	2" 50 mm	2-1/2" 65 mm	3" 80 mm	4" 100 mm	6" 150 mm	Notes
	Control Top	Contact Factory							
1	Actuator	See actuator parts list							
* 2	Bearing	102757+						106047+	
3	Adapter, W60 (Std.)	102406+	102407+	102408+	102409+	102410+	113822+		
3a	Adapter, W60 High	109293+	109294+	109295+	N/A				
	W80	116925+	116926+	116927+	N/A				
3b	Adapter, W80	106291+	106292+	106293+	106294+	106295+	114306+	2	
3d	Adapter, Wiping Stem Seal	117879+	117880+	117881+	117882+	117883+	P.O.A.	1	
* 4	O-ring	EPDM E70210						E70214	
		FKM V70210						V70214	
* 4a	Wiping Stem Seal	EPDM 116183+	116183+	116183+	116183+	116183+	P.O.A.	1	
		FKM 115626+					P.O.A.		
5	Clamp Standard	119-30	119-33	119-34	119-51	119-87	113827+		
	High Pressure	119-271	119-272	119-273	N/A			3	
* 6	O-ring, Bod	EPDM E70223	E70228	E70232	E70236	E70244	E70258		
		FKM V70223	V70228	V70232	V70236	V70244	V70258		
7	Stem (less seat ring):								
	Tef-Flow™	102417+	102418+	102419+	102420+	102421+	102422+	N/A	
	Tef-Flow™ Long Stroke	N/A	N/A	N/A	110967+	110968+	110969+	N/A	
	Tri Ring	108142+	108143+	108144+	108145+	108146+	108147+	114304+	
	Tri Ring, Long Stroke	N/A	N/A	N/A	110986+	110987+	110988+	P.O.A.	
	Metal	106398+	106399+	106400+	106401+	106402+	106403+	P.O.A.	
	Metal, Long Stroke	N/A	N/A	N/A	111001+	111002+	111003+	P.O.A.	
* 8	Seat Ring	Tef-Flow™ 20-240	20-241	20-242	20-243	20-244	N/A		
		Tef-Flow™ P 115347+	115348+	115349+	115350+	115351+	N/A		
		Tri Ring, EPDM 107692+	107695+	107048+	102488+	107698+	102738+		
		Tri Ring, FKM 107983+	107986+	107982+	107974+	107989+	108020+		
10	High Pressure Backup Ring	BURT210				N/A			

Notes:

PL5027-CH4

1. Wiping Stem Seal Adapter and Wiping Stem Seal options available for W60 Series valves only.
2. W80 Adapter allows for liquid or steam flush of stem o-ring only.
3. High Pressure Body Clamp only required for valves equipped with High Pressure Adapter (item 3a).

W64/W84 Tank Outlet Valve

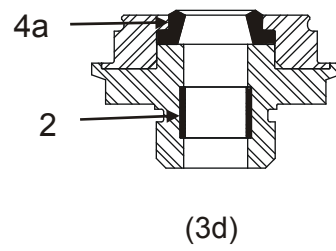
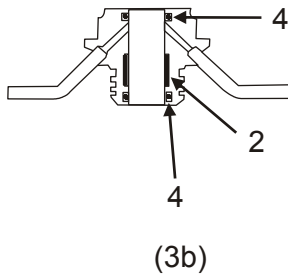
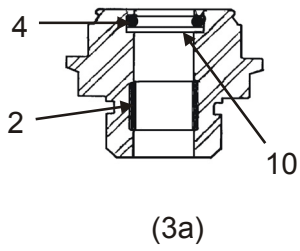
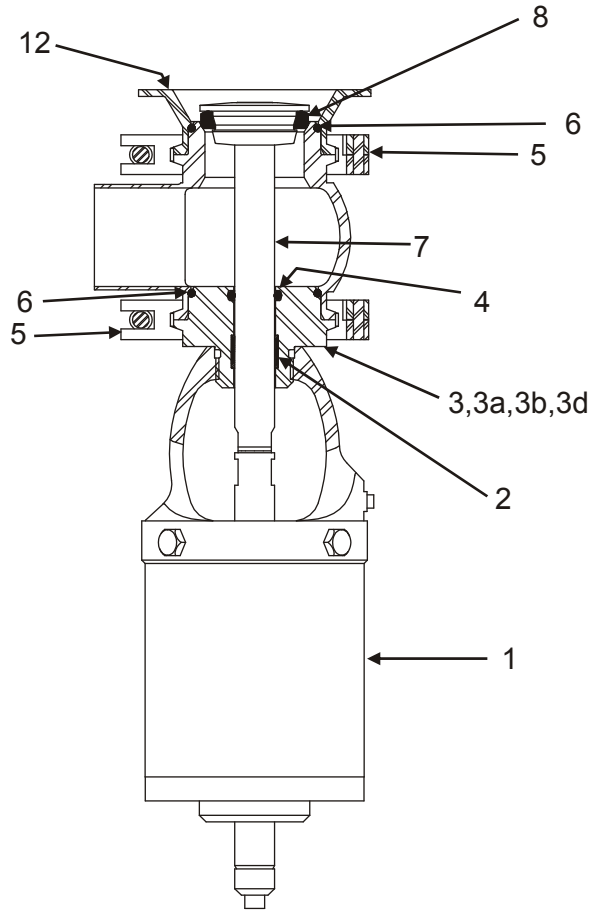

VA100-244

W64/W84 Tank Outlet Valve

Item #	Part Description	1" 25 mm	1-1/2" 40 mm	2" 50 mm	2-1/2" 65 mm	3" 80 mm	4" 100 mm	Notes	
	Control Top	Contact Factory							
1	Actuator	See actuator parts list							
* 2	Bearing	102757+							
3	Adapter, W60 (Std.)	102406+		102407+	102408+	102409+	102410+		
3a	Adapter, High Pressure	W60 W80	109293+	109294+	109295+	N/A			
3b	Adapter, W80		106291+	106292+	106293+	106294+	106295+	2	
3d	Adapter, Wiping Stem Seal		117879+	117880+	117881+	117882+	117883+	1	
* 4	O-ring	EPDM	E70210						
		FKM	V70210						
* 4a	Wiping Stem Seal	EPDM	116183+						1
		FKM	115626+						
5	Clamp	Standard High Pressure	119-30 119-271	119-33 119-272	119-34 119-273	119-51 N/A	119-87	3	
* 6	O-ring, Body	EPDM FKM	E70223 V70223	E70228 V70228	E70232 V70232	E70236 V70236	E70244 V70244		
7	Stem (less seat ring)	Tef-Flow™ Tef-Flow™ Long Stroke Tri Ring Tri Ring, Long Stroke Metal Metal, Long Stroke	102417+ N/A 108142+ N/A 106398+ N/A	102418+ N/A 108143+ N/A 106399+ N/A	102419+ N/A 108144+ N/A 106400+ N/A	102420+ 110967+ 108145+ 110986+ 106401+ 111001+	102421+ 110968+ 108146+ 110987+ 106402+ 111002+	102422+ 110969+ 108147+ 110988+ 106403+ 111003+	
* 8	Seat Ring	Tef-Flow™ Tef-Flow™ P Tri Ring, EPDM Tri Ring, FKM	20-240 115347+ 107692+ 107983+	20-241 115348+ 107695+ 107986+	20-242 115349+ 107048+ 107982+	20-243 115350+ 102488+ 107974+	20-244 115351+ 107698+ 107989+		
10	High Pressure Backup Ring		BURT210			N/A			
12	Tank Flange	1/8" Thick 1/4" Thick	114824+ 114829+	114825+ 114830+	114826+ 114831+	114827+ 114832+	114828+ 114833+		

PL5027-CH5

*** Recommended Spare Parts**

1. Wiping Stem Seal Adapter and Wiping Stem Seal options available for W60 Series valves only.
2. W80 Adapter allows for liquid or steam flush of stem o-ring only.
3. High Pressure Body Clamp only required for valves equipped with High Pressure Adapter (item 3a).

W64R/W84R Tank Outlet Valve

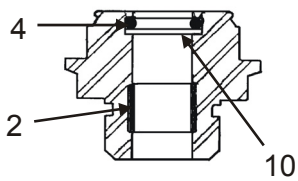
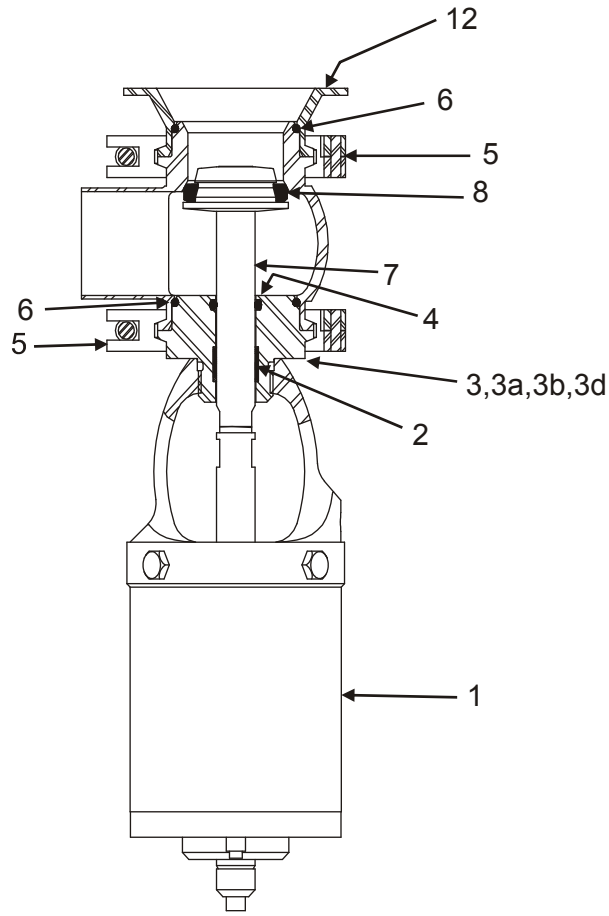

(3a)

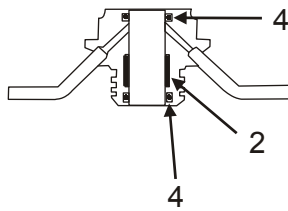

(3b)

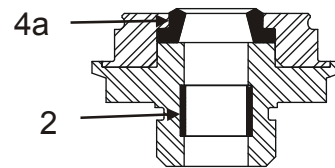

(3d)

VA100-244R

W64R/W84R Tank Outlet Valve

Item #	Part Description	1" 25 mm	1-1/2" 40 mm	2" 50 mm	2-1/2" 65 mm	3" 80 mm	4" 100 mm	Notes													
	Control Top	Contact Factory																			
1	Actuator	See actuator parts list																			
* 2	Bearing	102757+																			
3	Adapter, W60 (Std.)	102406+	102407+	102408+	102409+	102410+															
3a	Adapter, High Pressure	W60 109293+	W80 116925+	109294+	116926+	109295+	N/A N/A														
3b	Adapter, W80	106291+	106292+	106293+	106294+	106295+	2														
3d	Adapter, Wiping Stem Seal	117879+	117880+	117881+	117882+	117883+	1														
* 4	O-ring	EPDM E70210	FKM V70210	E70210	E70210	E70210	E70210														
* 4a	Wiping Stem Seal	EPDM 116183+	FKM 115626+	116183+	115626+	116183+	115626+	1													
5	Clamp	Standard 119-30	High Pressure 119-271	119-33	119-34	119-51	119-87 N/A	3													
* 6	O-ring, Body	EPDM E70223	FKM V70223	E70228	E70232	E70236	E70244														
7	Stem (less seat ring)	Tef-Flow™ 102411+	Tri Ring 108130+	Metal 106386+	102412+	102413+	102414+	102415+	102416+	108131+	108132+	107045+	108134+	108135+	106387+	106388+	106389+	106390+	106391+		
* 8	Seat Ring	Tef-Flow™ 20-240	Tef-Flow™ P 115347+	Tri Ring, EPDM 107692+	Tri Ring, FKM 107983+	20-241	115348+	107695+	107986+	20-242	115349+	1077048+	107982+	20-243	115350+	1077048+	107974+	20-244	115351+	107698+	107989+
10	High Pressure Backup Ring	BURT210				N/A															
12	Tank Flange	1/8" Thick 114824+	1/4" Thick 114829+	114825+	114826+	114827+	114828+														

PL5027-CH6

*** Recommended Spare Parts**

1. Wiping Stem Seal Adapter and Wiping Stem Seal options available for W60 Series valves only.
2. W80 Adapter allows for liquid or steam flush of stem o-ring only.
3. High Pressure Body Clamp only required for valves equipped with High Pressure Adapter (item 3a).

W64ET Tank Outlet Valve

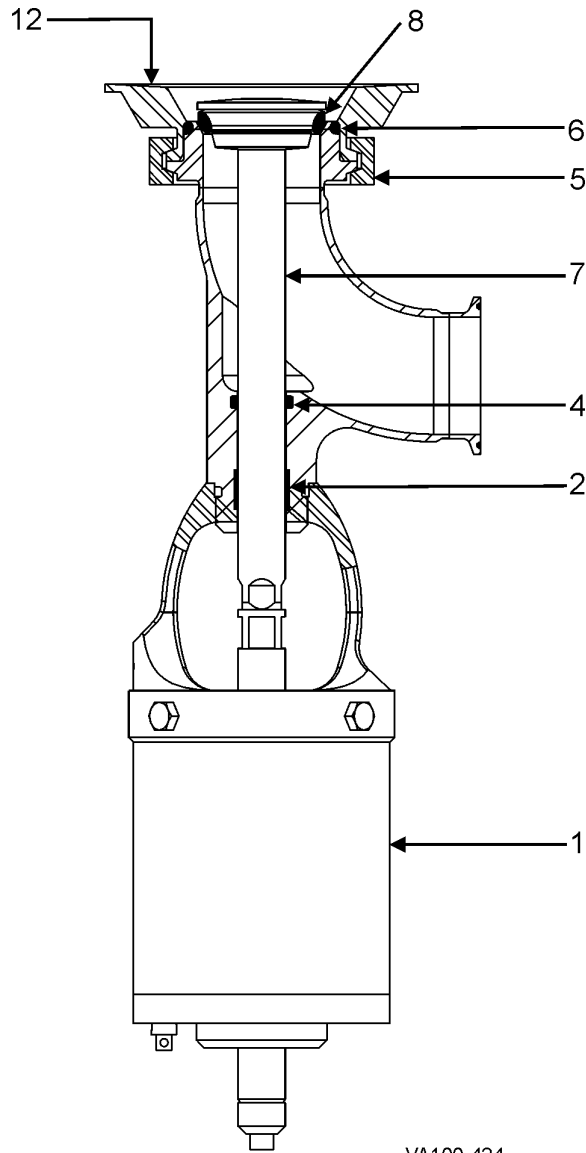

VA100-424

W64ET Tank Outlet Valve

Item #	Part Description	2"	2-1/2"	3"
	Control Top	Contact Factory		
1	Actuator	See actuator parts list		
* 2	Bearing	102757+		
* 4	O-ring EPDM	E70210		
	FKM	V70210		
5	Clamp Standard	119-33	119-34	119-51
* 6	O-ring, Body EPDM	E70228	E70232	E70236
	FKM	V70228	V70232	V70236
7	Stem (less seat ring) Tef-Flow™	117915+	117916+	117917+
	Tri Ring	117919+	117920+	117921+
* 8	Seat Ring Tef-Flow™	20-241	20-242	20-243
	Tef-Flow™ P	115348+	115349+	115350+
	Tri Ring, EPDM	107695+	107048+	102488+
	Tri Ring, FKM	107986+	107982+	107974+
12	Tank Flange 1/8" Thick	114825+	114826+	114827+
	1/4" Thick	114830+	114831+	114832+

PL5027-CH7

* Recommended Spare Parts

W65/W85 Non-Slam Divert Valve

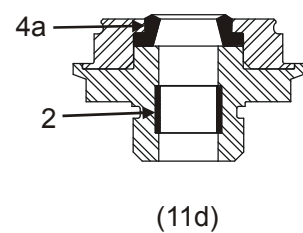
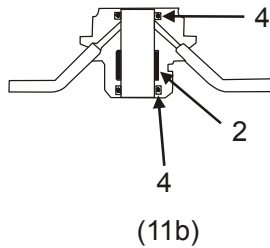
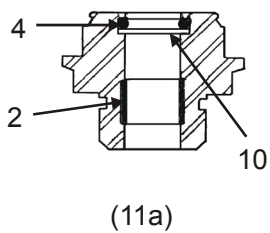
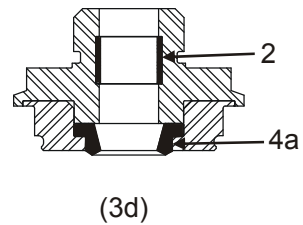
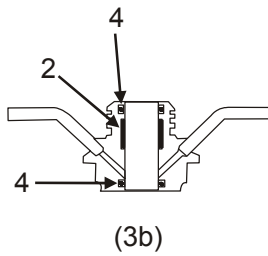
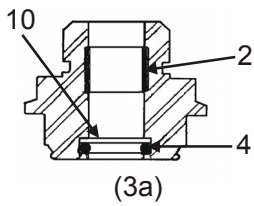
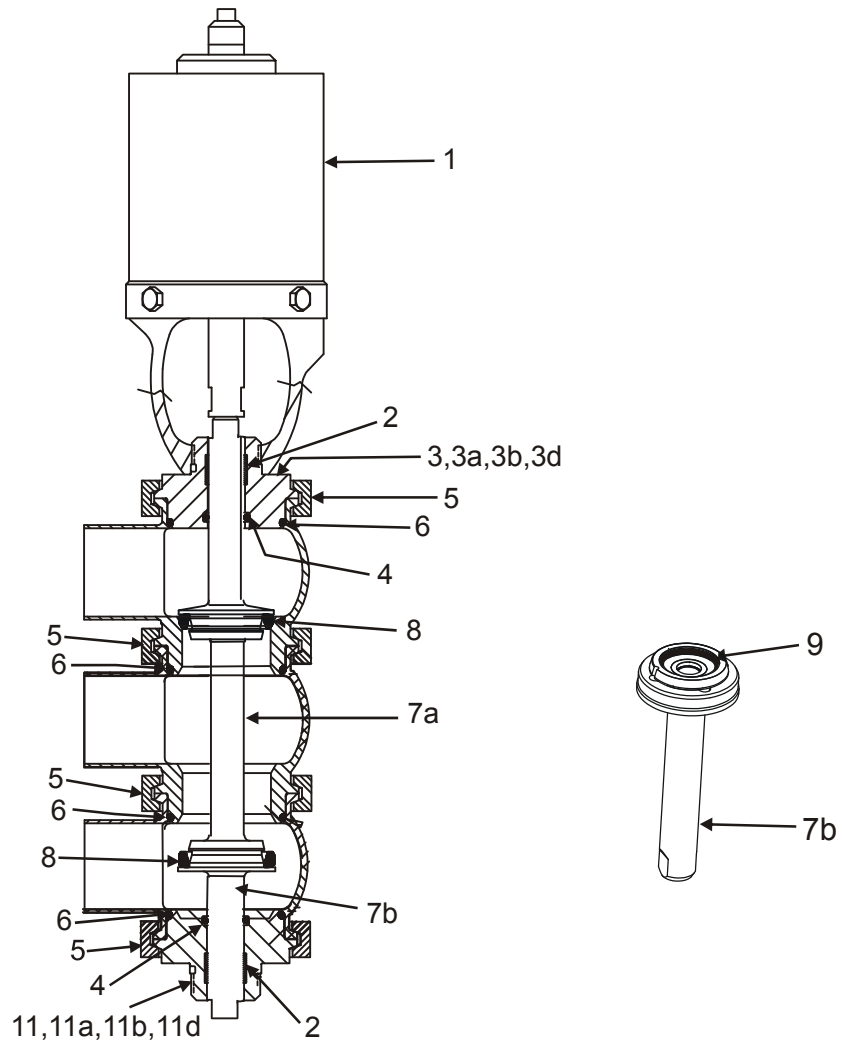

VA100-245

W65/W85 Non-Slam Divert Valve

Item #	Part Description	1" 25 mm	1-1/2" 40 mm	2" 50 mm	2-1/2" 65 mm	3" 80 mm	4" 100 mm	Notes
	Control Top	Contact Factory						
1	Actuator	See actuator parts list						
* 2	Bearing	102757+						
3	Adapter, Upper - W60 (Std.)	102406+	102407+	102408+	102409+	102410+		
3a	Adapter, Upper -High Pressure	W60 109293+	109294+	109295+	N/A			
		W80 116925+	116926+	116927+	N/A			
3b	Adapter, Upper - W80	106291+	106292+	106293+	106294+	106295+	2	
3d	Adapter, Upper-Wiping Stem	117879+	117880+	117881+	117882+	117883+	1	
* 4	O-ring	EPDM E70210						
		FKM V70210						
* 4a	Wiping Stem Seal	EPDM 116183+						1
		FKM 115626+						
5	Clamp	Standard 119-30	119-33	119-34	119-51	119-87		
		High Pressure 119-271	119-272	119-273	N/A		3	
* 6	O-ring, Body	EPDM E70223						
		FKM V70223						
7a	Stem, Upper (less seat ring)	Tef-Flow™ 121963+	121963+	121964+	121965+	121966+	121967+	
		Tri Ring POA	128178+	127799+	124016+	128347+	128358+	
		Metal POA	POA	131663+	129233+	130984+	POA	
7b	Stem, Lower (less seat ring):							
	Tef-Flow™	121974+	121975+	121976+	121977+	121978+	121979+	
	Tef-Flow™ Long Stroke	N/A	N/A	N/A	125952+	125954+	125958+	
	Tri Ring	POA	128179+	127800+	124018+	128349+	128360+	
	Tri Ring, Long Stroke	N/A	N/A	N/A	POA	POA	POA	
	Metal	106286+	106286+	131712+	129232+	130983+	POA	
	Metal, Long Stroke	N/A	N/A	N/A	POA	POA	POA	
* 8	Seat Ring	Tef-Flow™ 20-240						
		Tef-Flow™ P 115347+						
		Tri Ring, EPDM 107692+						
		Tri Ring, FKM 107983+						
* 9	O-ring, Lower Stem	EPDM E70206						
		FKM V70206						
10	High Pressure Backup Ring	BURT210				N/A		
11	Adapter, Lower - W60 (Std.)	106329+	106240+	106241+	106242+	106243+		
11a	Adapter, Lower - High Pressure	W60 103632+	103634+	103635+	N/A		3	
		W80 116930+	116932+	116933+	N/A			
11b	Adapter, Lower - W80	106328+	106297+	106298+	106299+	106300+	2	
11d	Adapter, Lower-Wiping Stem Seal	117979+	117981+	117982+	117983+	117984+	1	

Notes

PL5027-CH8

*** Recommended Spare Parts**

1. Wiping Stem Seal Adapter and Wiping Stem Seal options are available for the W60 Series valves only.
2. W80 Adapter allows for liquid or steam flush of the stem o-ring only.
3. High Pressure Body Clamp is only required for valves equipped with High Pressure Adapters (items 3a and 11a).

W60/W80 Series Single Seat Valve Bodies

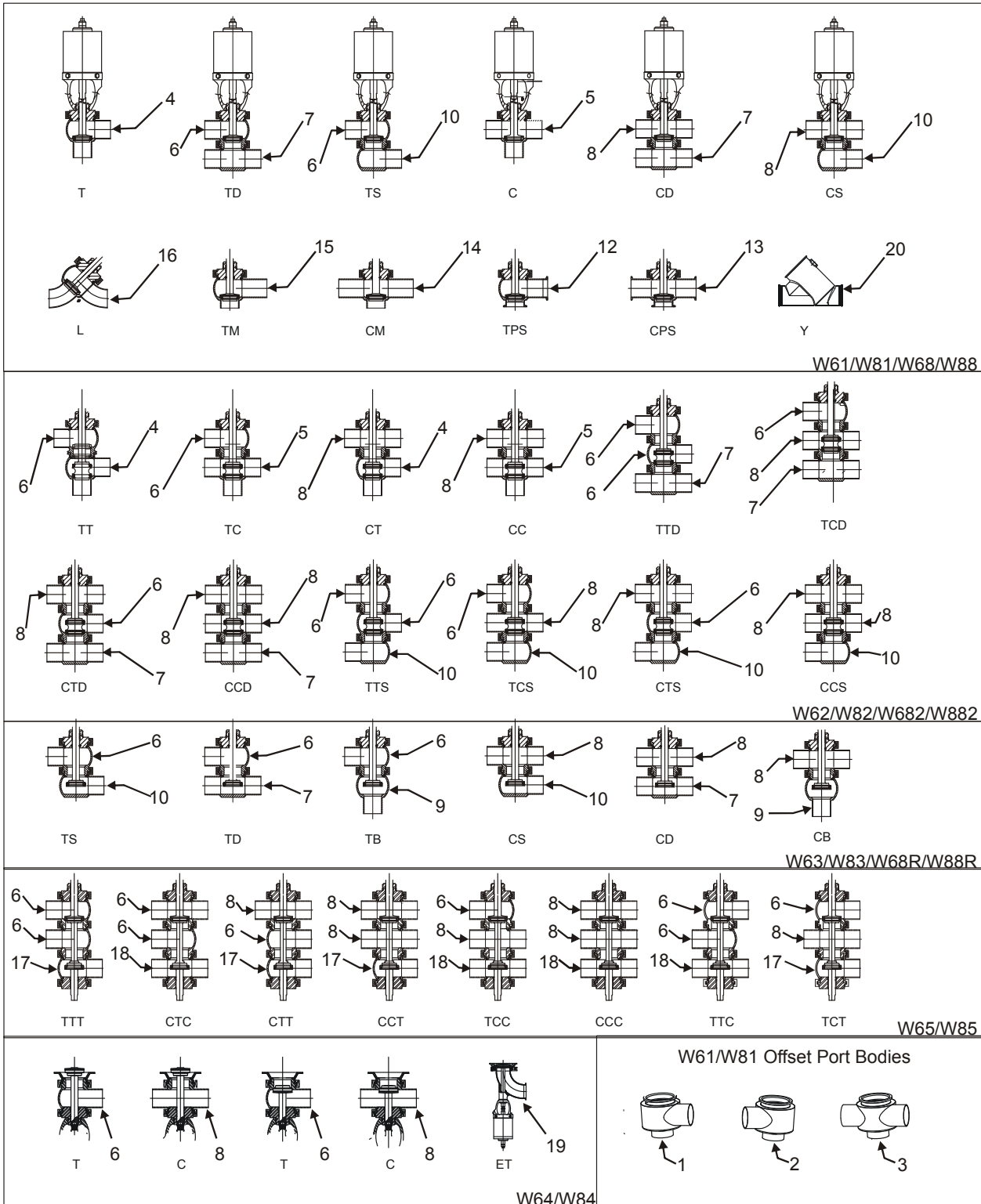

W61/W81/W68/W88

W62/W82/W682/W882

W63/W83/W68R/W88R

W65/W85

W64/W84

VA100-363

W60/W80 Series Single Seat Valve Bodies - inch O.D. Tube sizes

Item	Part Description		1"	1-1/2"	2"	2-1/2"	3"	4"	6" ¹
1	Tee, Offset Port - Right (TOPR)	Buttweld	108321+	108322+	108323+	108324+	108325+	108326+	116739+
		S-Line	108433+	108438+	108443+	108448+	108453+	108458+	POA
2	Tee, Offset Port - Left (TOPL)	Buttweld	108327+	108328+	108329+	108330+	108331+	108332+	116735+
		S-Line	108463+	108468+	108473+	108478+	108483+	108488+	118920+
3	Cross, Offset Port (COP)	Buttweld	108333+	108334+	108335+	108336+	108337+	108338+	POA
		S-Line	108493+	108498+	108503+	108508+	108513+	108518+	POA
4	Tee (T)	Buttweld	102400+	102401+	102402+	102403+	102404+	102405+	114296+
		S-Line	104143+	104147+	104151+	104155+	104159+	104163+	117205+
5	Cross (C)	Buttweld	102449+	102450+	102451+	102452+	102453+	102454+	114297+
		S-Line	104191+	104195+	104199+	104203+	104207+	104211+	POA
6	Upper Tee (T)	Buttweld	102144+	102145+	102146+	102147+	102148+	102149+	119245+
		S-Line	104167+	104171+	104175+	104179+	104183+	104187+	119247+
7	Double Side Port (D)	Buttweld	102785+	102786+	102787+	102788+	102789+	102790+	POA
		S-Line	104263+	104267+	104271+	104275+	104279+	104283+	POA
8	Upper Cross (C)	Buttweld	102455+	102456+	102457+	102458+	102459+	102460+	119246+
		S-Line	104215+	104219+	104223+	104227+	104231+	104235+	POA
9	Lower Bottom Port (B)	Buttweld	102779+	102780+	102781+	102782+	102783+	102784+	POA
		S-Line	104287+	104291+	104295+	104299+	104923+	104927+	POA
10	Single Side Port (S)	Buttweld	102773+	102774+	102775+	102776+	102777+	102778+	POA
		S-Line	104239+	104243+	104247+	104251+	104255+	104259+	POA
12	Tee, Port Short (TPS)	S-Line	111709+	111710+	111711+	111712+	109955+	111713+	POA
13	Cross, Port Short (CPS)	S-Line	112408+	112409+	112410+	112411+	112412+	112413+	POA
14	Cross, Manifold (CM)	Buttweld	105586+	105587+	105588+	105589+	105590+	105591+	POA
15	Tee, Manifold (TM)	Buttweld	105580+	105581+	105582+	105583+	105584+	105585+	POA
16	In-line Body (L)	Buttweld	107685+	107686+	107687+	107688+	107689+	107690+	POA
		S-Line	107702+	107706+	107710+	107714+	107718+	107722+	POA
17	Lower Tee (T)	Buttweld	106269+	106061+	106062+	106063+	106064+	106065+	124955+
		S-Line	106341+	106345+	106349+	106353+	106357+	106361+	POA
18	Lower Cross (C)	Buttweld	106270+	106262+	106263+	106264+	106265+	106266+	124956+
		S-Line	106365+	106369+	106373+	106377+	106381+	106385+	POA
20	Y Body (Y) ¹	Buttweld	POA	POA	POA	121663+	121769+	121770+	POA
		S-Line	POA	POA	POA	119556+	119555+	119554+	POA

Notes:

FL5027-CH20

1. Bodies and 6" sizes are not currently available for W68, W88 or W90 series.

POA: Contact Factory

4" (101 mm) and 5" (127 mm) Air-to-Spring or Air-to-Air Actuators

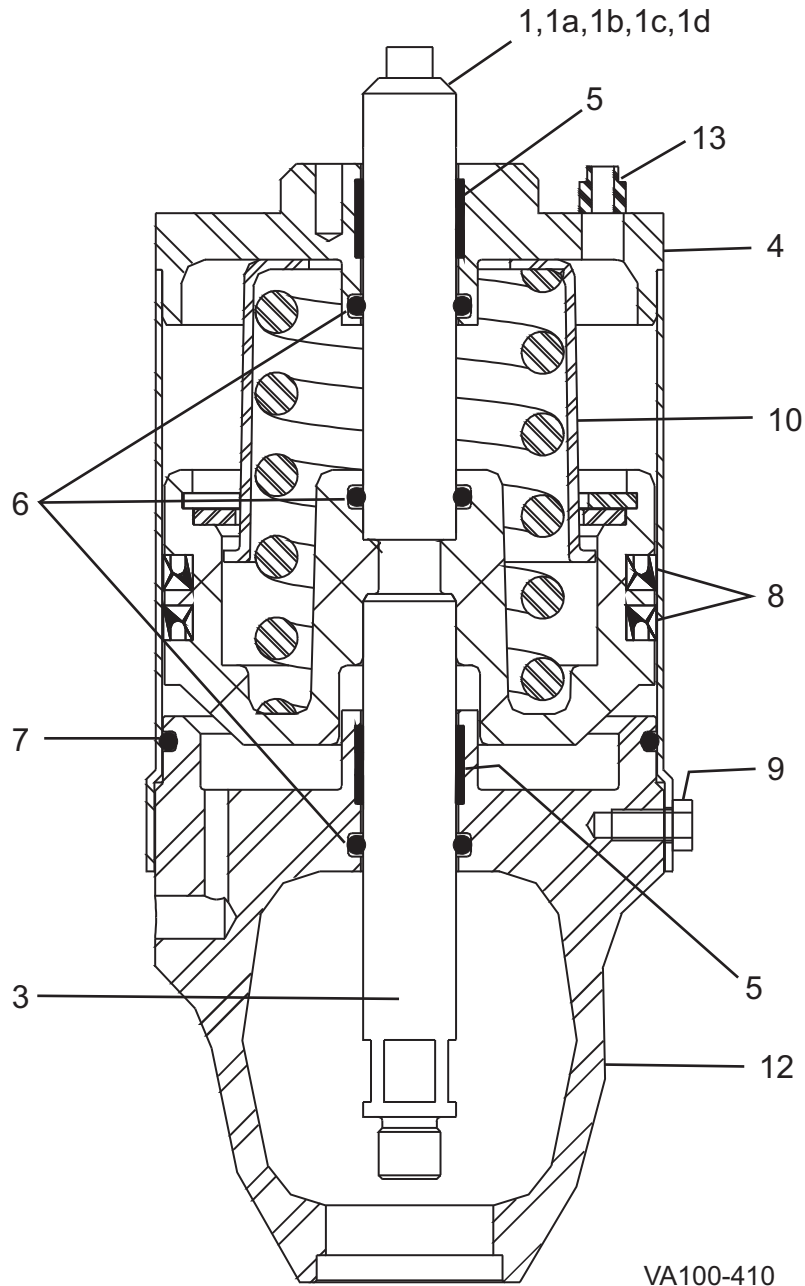

4" (101 mm) and 5" (127 mm) Air-to-Spring or Air-to-Air Actuators

Item #	Part Description	4" Diameter (101 mm)	5" Diameter (127 mm)	Notes	
1	Indicator Stem - Visual	121007+	118937+		
1a	Indicator Stem - WCB 2-piece Control Top	118938+	118939+		
1b	Indicator Stem - Bürkert 8681 Control Top	131069+		2	
1c	Indicator Stem - CU4 control Top	130390+		2	
1d	Indicator Stem - Set and forget	119677+		3	
3	Stem, Lower	102141+	102134+		
4	Cylinder	102136+	102130+		
* 5	Bearing, Cylinder	102757+	102757+		
* 6	O-ring Nitrile	N70210	N70210		
* 7	O-ring, Cylinder Nitrile	N70240	N70248		
* 8	Seal, U-cup	57-15	120026+		
9	Cap Screw, 1/4-20 x .375" lg.	30-68	30-68		
10	Piston & Spring Assembly	Standard Spring	118144+	118145+	5
		Heavy Duty Spring	118146+	118147+	
		Air-to-Air (no spring)	118148+	118149+	
12	Yoke	102137+	102131+		
13	Vent Plug	3023957+	3023957+		
Actuator Seal Kit (contains recomm. spares)		106324+	106325+		

Complete Actuator Assemblies

Part Description	Spring	4" Diameter (101 mm)	5" Diameter (127 mm)	Notes
Air-to-Raise Visual Indicator Stem	Standard	ACT00205	ACT00206	2
	Heavy Duty	ACT00207	ACT00208	
Control Top Indicator Stem	Standard	ACT00215	ACT00216	3
	Heavy Duty	ACT00217	ACT00218	
Air-to-Lower Visual Indicator Stem	Standard	ACT00209	ACT00210	2
	Heavy Duty	ACT00211	ACT00212	
Control Top Indicator Stem	Standard	ACT00219	ACT00220	3
	Heavy Duty	ACT00221	ACT00222	
Air-to-Air Visual Indicator Stem		ACT00213	ACT00214	2
	Control Top Indicator Stem		ACT00223	ACT00224

Notes

PL5027-CH21

* Recommended Spare Parts

- Air-to-Air is the same as Air-to-Raise without use of a spring.
(part # 5900032+ on 4-inch (101 mm) actuator, part # 5900035+ on 5-inch (127 mm) actuator)
- Stem only - does not include target
- Stem for use with WCB 2-piece control top
- SPX FLOW does not recommend any attempt at disassembly or replacement of the spring in the piston assembly – please replace the entire caged piston & spring assembly when necessary.

6" (152 mm) Air-to-Spring or Air-to-Air Actuators

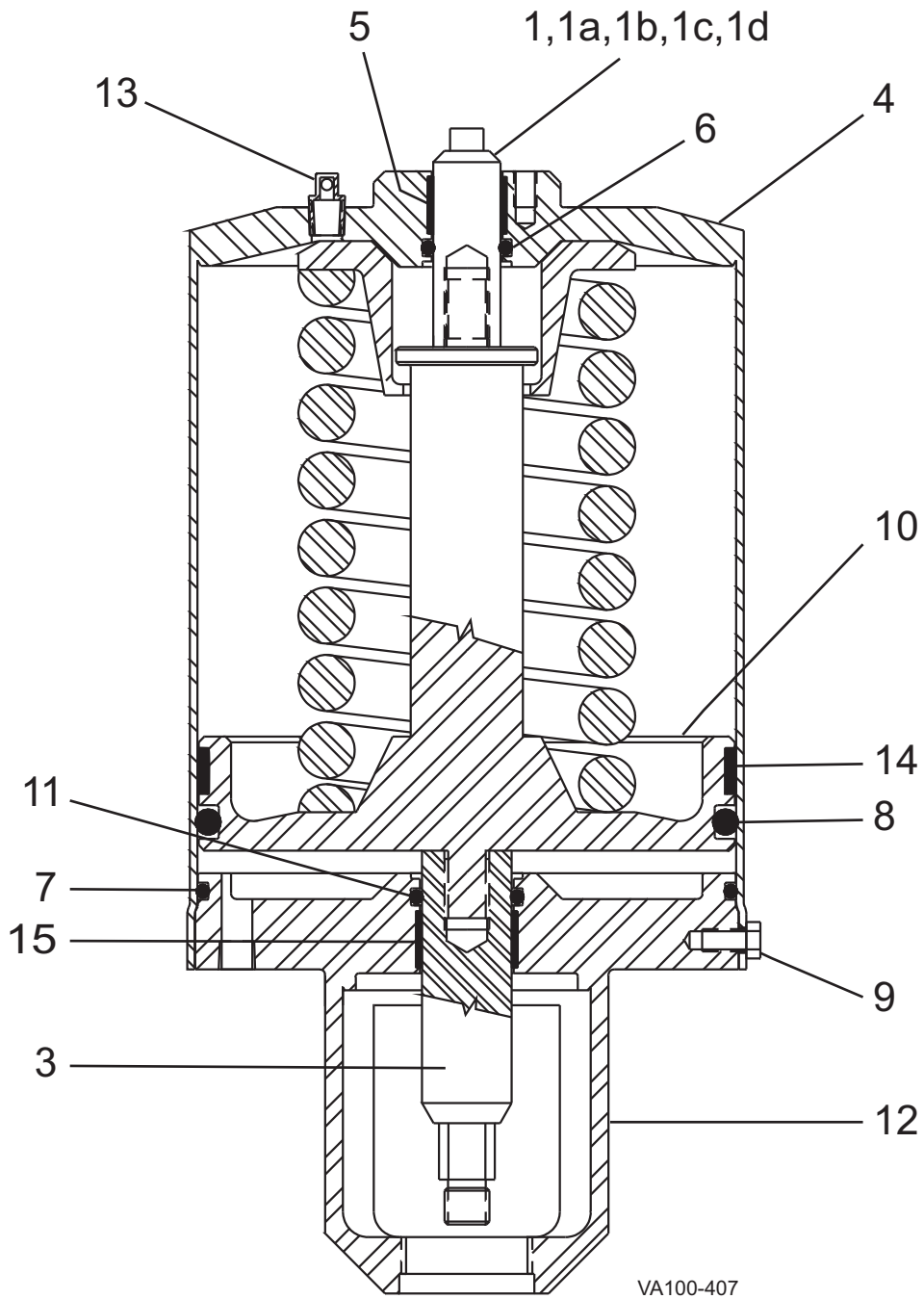

6" (152 mm) Air-to-Spring or Air-to-Air Actuators

Item #	Part Description	6" (152 mm) Diameter	Notes	
1	Indicator Stem - Visual	108834+		
1a	Indicator Stem - WCB 2-piece Control Top	108830+		
1b	Indicator Stem - Bürkert 8681 Control Top	131506+	2	
1c	Indicator Stem - CU4 control Top	131216+	2	
1d	Indicator Stem - Set and forget	119681+	3	
3	Stem, Lower	108825+		
4	Cylinder	106007+		
* 5	Bearing, Cylinder	102757+		
* 6	O-ring Nitrile	N70210		
* 7	O-ring, Cylinder Nitrile	N70255		
* 8	O-Ring, Piston Nitrile	N70433		
9	Cap Screw, 1/4-20 x .375" lg.	30-68		
10	Piston & Spring Assembly	Standard Spring Heavy Spring Air-to-Air (no spring)	110288+ 108832+ 118200+	5
* 11	O-ring Nitrile	N70214		
12	Yoke	108827+		
13	Vent Plug	3023957+		
* 14	Bearing, Piston	102052+		
* 15	Bearing, Yoke	106047+		
Actuator Seal Kit (contains recomm. spares)		129867+		

Complete Actuator Assemblies

Part Description	Spring	6" (152 mm) Diameter	Notes
Air-to-Raise Visual Indicator Stem	Standard	ACT00225	2
	Heavy	ACT00226	
Control Top Indicator Stem	Standard	ACT00227	3
	Heavy	ACT00228	
Air-to-Lower Visual Indicator Stem	Standard	ACT00229	2
	Heavy	ACT00230	
Control Top Indicator Stem	Standard	ACT00231	3
	Heavy	ACT00232	
Air-to-Air Visual Indicator Stem		ACT00233	2
	Control Top Indicator Stem		ACT00234

Notes

PL5027-CH23

* Recommended Spare Parts

1. Air-to-Air is the same as Air-to-Raise without use of a spring.
2. Stem only - does not include target
3. Stem for use with WCB 2-piece control top
4. This actuator is for W60/W80/W90 series valves.
5. SPX FLOW does not recommend any attempt at disassembly or replacement of the spring in the piston assembly – please replace the entire caged piston & spring assembly when necessary.

4" (101 mm) and 6" (152 mm) Air-to-Spring Long Stroke Actuator

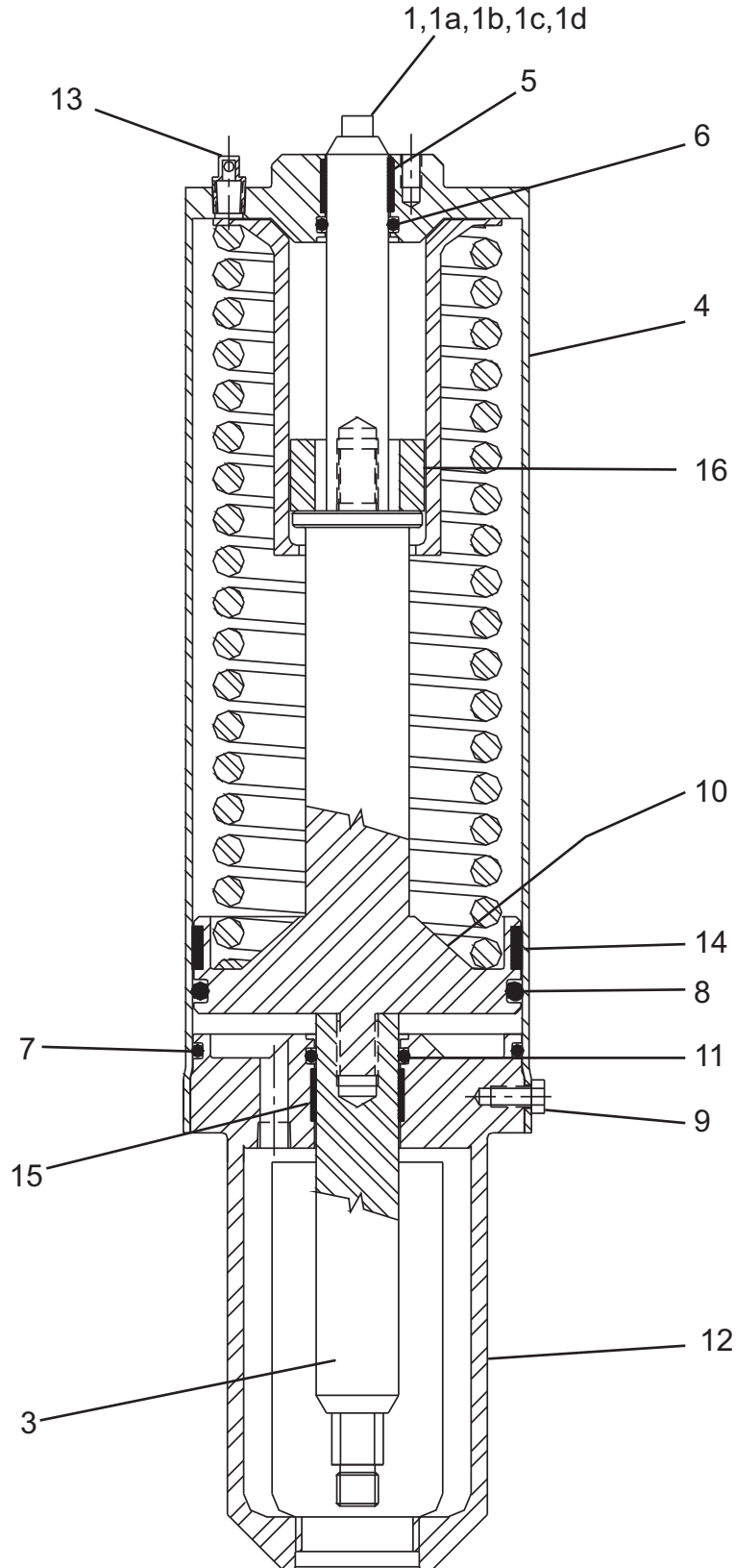

VA100-406

4" (101 mm) and 6" (152 mm) Air-to-Spring Long Stroke Actuator

Item	Part Description	4" (101 mm) Diameter	6" (152 mm) Diameter	6" (152 mm) Dia. XL	Notes
1	Indicator Stem - Visual	110296+		119601+	
1a	Indicator Stem - WCB 2-piece Control Top	110800+		N/A	
1b	Indicator Stem - Bürkert 8681 Control Top	134716+		N/A	2
1c	Indicator Stem - CU4 control Top	N/A			2
1d	Indicator Stem - Set and forget	119679+		N/A	3
3	Air-to-Raise, 2-1/2" or 65 mm model valve	114195+	110299+	118527+	
	Air-to-Raise, 3" or 80 mm model valve	114195+	110299+	118527+	
	Air-to-Raise, 4" or 100 mm model valve	114195+	110299+	118527+	
	Air-to-Lower, 2-1/2" or 65 mm model valve	114603+	108869+	118527+	
	Air-to-Lower, 3" or 80 mm model valve	110299+	110870+	118527+	
	Air-to-Lower, 4" or 100 mm model valve	114195+	110299+	118527+	
4	Cylinder	114191+	110297+	119572+	
* 5	Bearing, Cylinder	102757+			
* 6	O-ring Nitrile	N70210			
* 7	O-ring, Cylinder Nitrile	N70240			
* 8	O-ring, Piston Nitrile	N70342			
9	Cap Screw, 1/4-20 x .375" lg.	30-68			
10	Piston & Spring Assembly	114197+	110293+	119573+	5
* 11	O-ring Nitrile	N70214			
12	Yoke	114192+	110298+	119571+	
13	Vent Plug	3023957+			
* 14	Bearing, Piston	101995+	102052+	102052+	
* 15	Bearing, Yoke	106047+			
16	Spacer 2-1/2" or 65 mm model valve	110868+		N/A	
	3" or 80 mm model valve	110871+		N/A	
	4" or 100 mm model valve	N/A			
Actuator Seal Kit (contains recomm. spares)		134420+	129687+		

Complete Actuator Assemblies (see note 4)

Part Description	Valve Model		4" (101 mm)	6" (152 mm)	6" (152 mm)	Notes
	inch	mm	Diameter	Diameter	Dia. XL	
Air-to-Raise Visual Indicator Stem	2-1/2	65	ACT00131	ACT00239	POA	2
	3	80	ACT00123	ACT00110	POA	2
	4	100	ACT00235	ACT00115	POA	2
Control Top Indicator Stem	2-1/2	65	ACT00134	ACT00248	POA	3
	3	80	ACT00243	ACT00249	POA	3
	4	100	ACT0244	ACT00250	POA	3
Air-to-Lower Visual Indicator Stem	2-1/2	65	ACT00236	ACT00240	POA	2
	3	80	ACT00237	ACT00241	POA	2
	4	100	ACT00238	ACT00242	POA	2
Control Top Indicator Stem	2-1/2	65	ACT00245	ACT00251	POA	3
	3	80	ACT00246	ACT00252	POA	3
	4	100	ACT00247	ACT00253	POA	3

Notes

PL5027-CH25

* Recommended Spare Parts

- Long stroke actuators are not available for the W90 series diaphragm stem valves.
- Stem only - does not include target
- Stem for use with WCB 2-piece control top
- Assemblies are different for each valve size.
- SPX FLOW does not recommend any attempt at disassembly or replacement of the spring in the piston assembly – please replace the entire caged piston & spring assembly when necessary.

6" (152 mm) Air-to-Air Long Stroke Actuator

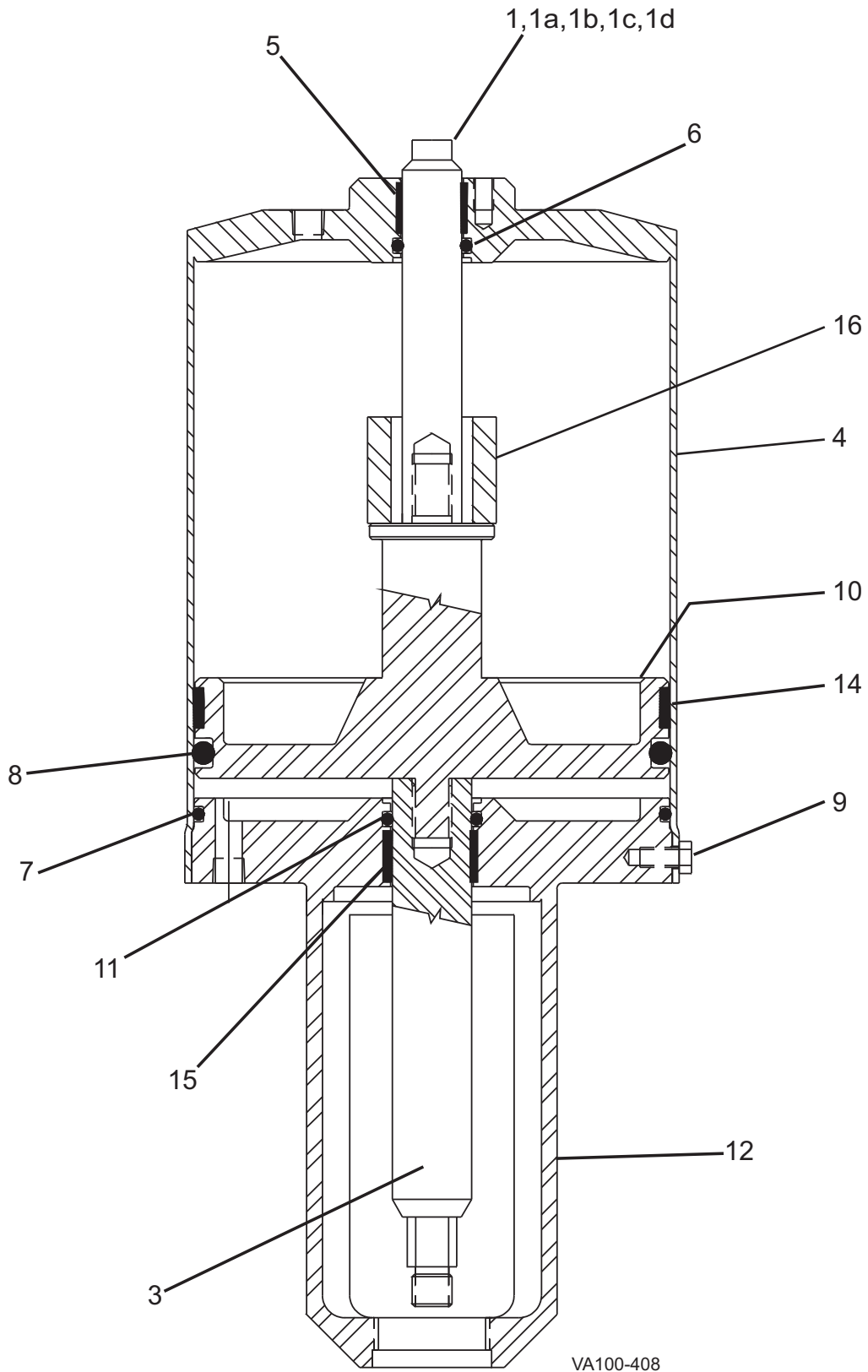

6" (152 mm) Air-to-Air Long Stroke Actuator

Item #	Part Description	6" (152 mm) Diameter	Notes
1	Indicator Stem - Visual	110296+	
1a	Indicator Stem - WCB 2-piece Control Top	110800+	
1b	Indicator Stem - Bürkert 8681 Control Top	134716+	2
1c	Indicator Stem - CU4 control Top	N/A	2
1d	Indicator Stem - Set and forget	119679+	3
3	Stem, Lower 2-1/2" or 65 mm model valve 3" or 80 mm model valve 4" or 100 mm model valve	110299+	
		110299+	
		110299+	
4	Cylinder	106007+	
* 5	Bearing, Cylinder	102757+	
* 6	O-ring Nitrile	N70210	
* 7	O-ring, Cylinder Nitrile	N70255	
* 8	O-ring, Piston Nitrile	N70433	
9	Cap Screw, 1/4-20 x .375" lg.	30-68	
10	Piston Assembly	118239+	
* 11	O-ring Nitrile	N70214	
12	Yoke	110298+	
* 14	Bearing, Piston	102052+	
* 15	Bearing, Yoke	106047+	
16	Spacer 2-1/2" or 65 mm model valve 3" or 80 mm model valve 4" or 100 mm model valve	110868+	
		110871+	
		N/A	
Actuator Seal Kit (contains recomm. spares)		129867+	

Complete Actuator Assemblies (see note 4)

Part Description	Valve Model		6" (152 mm) Diameter	Notes
	inch	mm		
Air-to-Air Visual Indicator Stem	2-1/2	65	ACT00258	2
	3	80	ACT00259	2
	4	100	ACT00260	2
Control Top Indicator Stem	2-1/2	65	ACT00261	3
	3	80	ACT00262	3
	4	100	ACT00263	3

Notes

PL5027-CH27

* Recommended Spare Parts

1. Long stroke actuators are not available for the W90 series diaphragm stem valves.
2. Stem only - does not include target
3. Stem for use with WCB 2-piece control top
4. Assemblies are different for each valve size.

4" (101 mm) Air-to-Raise 3-Position Actuator

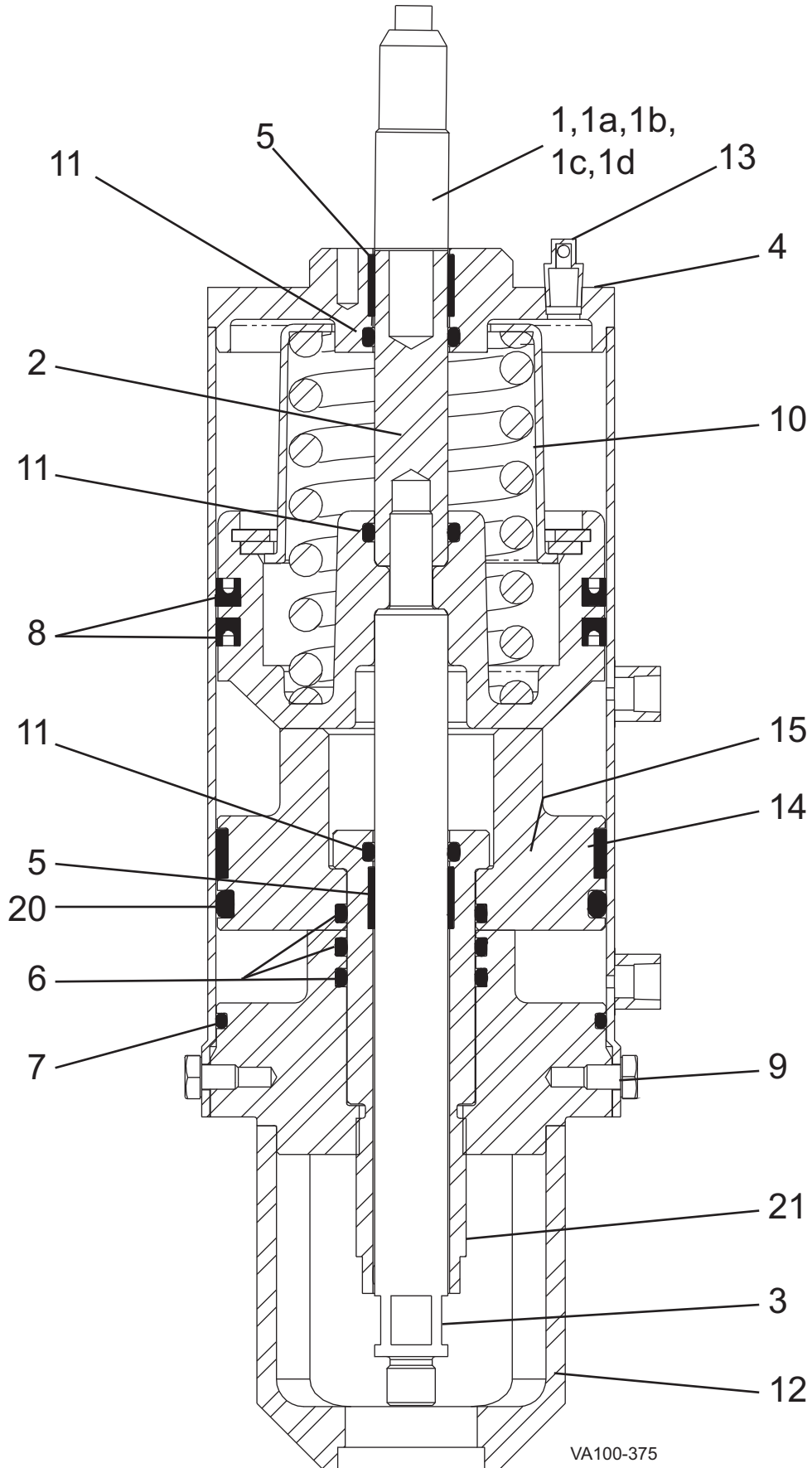

4" (101 mm) Air-to-Raise 3-Position Actuator

Item #	Part Description	4" (101 mm) Diameter	Notes
1	Indicator Stem - Visual	102143+	
1a	Indicator Stem - WCB 2-piece Control Top	118938+	
1b	Indicator Stem - Bürkert 8681 Control Top	131069+	2
1c	Indicator Stem - CU4 control Top	130390+	2
1d	Indicator Stem - Set and forget	119677+	3
2	Stem, Upper	102142+	
3	Stem, Lower	114394+	
4	Cylinder	114388+	
* 5	Bearing	102757+	
* 6	O-ring Nitrile	N70219	
* 7	O-ring, Cylinder Nitrile	N70240	
* 8	Seal, U-cup	57-15	
9	Cap Screw, 1/4-20 x .375" lg.	30-68	
10	Piston & Spring Assembly	118144+	5
* 11	O-ring Nitrile	N70210	
12	Yoke	114387+	
13	Vent Plug	3023957+	
* 14	Bearing, Piston	101995+	
15	Piston, Lower	114391+	
* 20	O-ring, Lower Piston Nitrile	N70342	
21	Stem, Outer	114393+	
Actuator Seal Kit (contains recomm. spares)		134421+	

Complete Actuator Assemblies

Part Description	4" (101 mm) Diameter	Notes
Air-to-Raise Visual Indicator Stem	ACT00127	2
Control Top Indicator Stem	ACT00254	3

PL5027-CH29

Notes

* Recommended Spare Parts

2. Stem only - does not include target
3. Stem for use with WCB 2-piece control top
5. SPX FLOW does not recommend any attempt at disassembly or replacement of the spring in the piston assembly – please replace the entire caged piston & spring assembly when necessary.

4" (101 mm) Air-to-Lower 3-Position Actuator

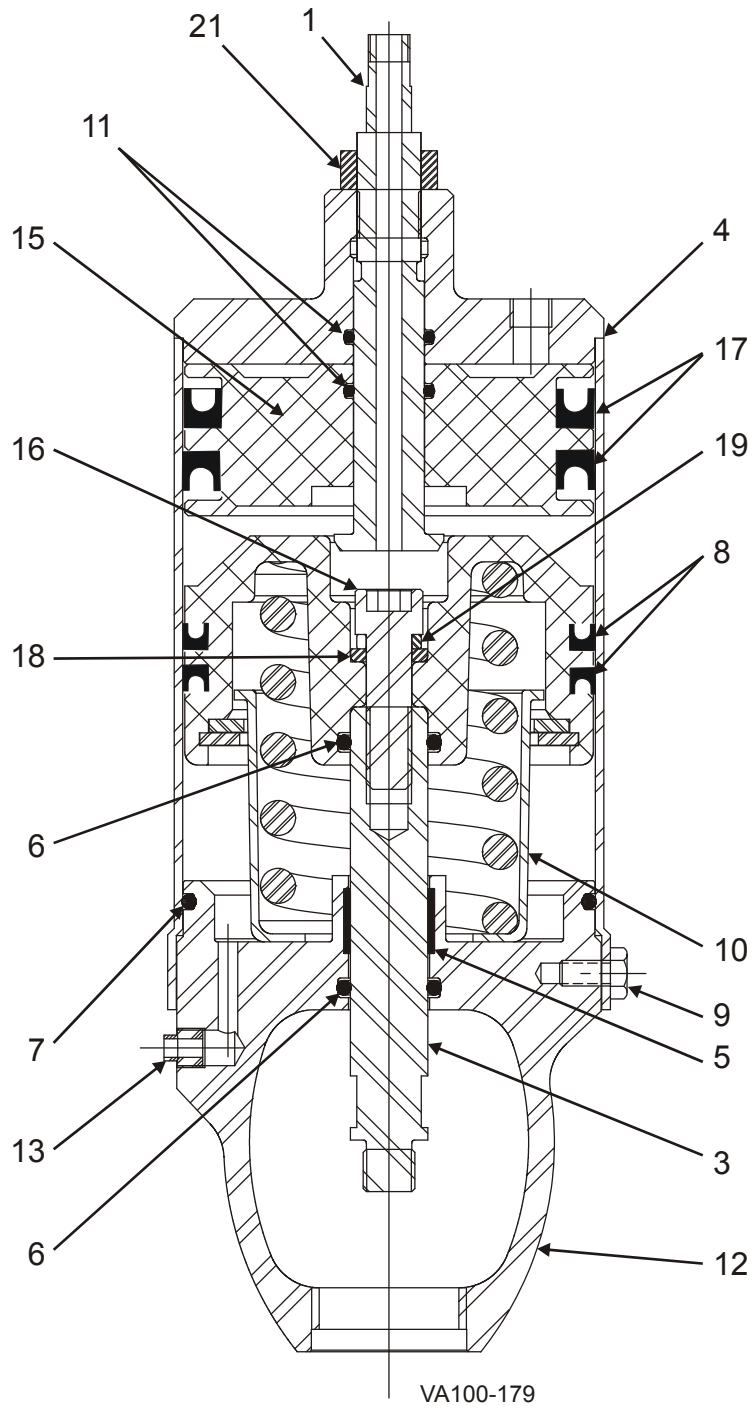

4" (101 mm) Air-to-Lower 3-Position Actuator

Item #	Part Description	4" (101 mm) Diameter	Notes
1	Stop, Adjustable (Upper)	45417+	
3	Stem, Lower	105793+	
4	Cylinder	105794+	
* 5	Bearing, Yoke	102757+	
* 6	O-ring Nitrile	N70210	
* 7	O-ring, Cylinder Nitrile	N70240	
* 8	Seal, U-cup - Main Piston	57-15	
9	Cap Screw, 1/4-20 x .375" lg.	30-68	
10	Piston & Spring Assembly	118144+	
* 11	O-ring Nitrile	N70115	
12	Yoke	102137+	
13	Vent Plug	3023957+	
15	Piston, Upper	70162+	5
16	Cap Screw, 7/16-14 x 1.5"	30-332	
* 17	Seal, U-cup - Upper Piston	57-11	
18	Washer	3023961+	
19	Lock Washer	9570210+	
21	Hex Jam Nut	36-79	
Actuator Seal Kit (contains recomm. spares)		134422+	

Complete Actuator Assemblies

Air-to-Lower	105792+
--------------	---------

PL5027-CH31

Notes

* Recommended Spare Parts

5. SPX FLOW does not recommend any attempt at disassembly or replacement of the spring in the piston assembly – please replace the entire caged piston & spring assembly when necessary.

**4" (101 mm), 5" (127 mm) and 6" (152 mm)
Air-to-Raise Adjustable-Spring Actuator**

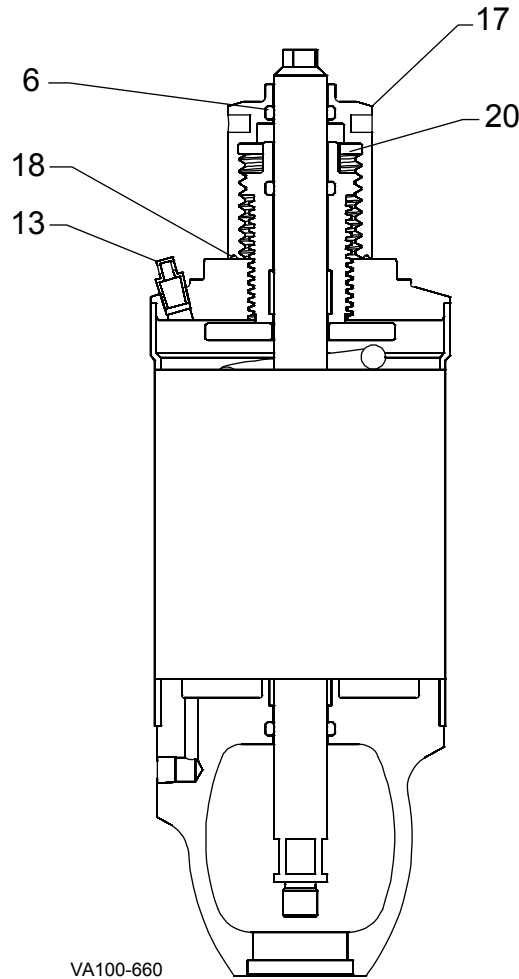

VA100-660

Item #	Part Description	4" (101 mm) Diameter	5" (127 mm) Diameter	6" (152 mm) Diameter
* 6	O-ring Nitrile	N70210		
13	Vent Plug	3023957+	3023957+	
17	Locknut, Cover	124058+	124058+	
* 18	O-ring Nitrile	N70032		
20	Screw, Adjusting	124057+		

* Recommended Spare Parts

PL5027-CH79

**4" (101 mm), 5" (127 mm) and 6" (152 mm)
Air-to-Lower Adjustable-Spring Actuator**

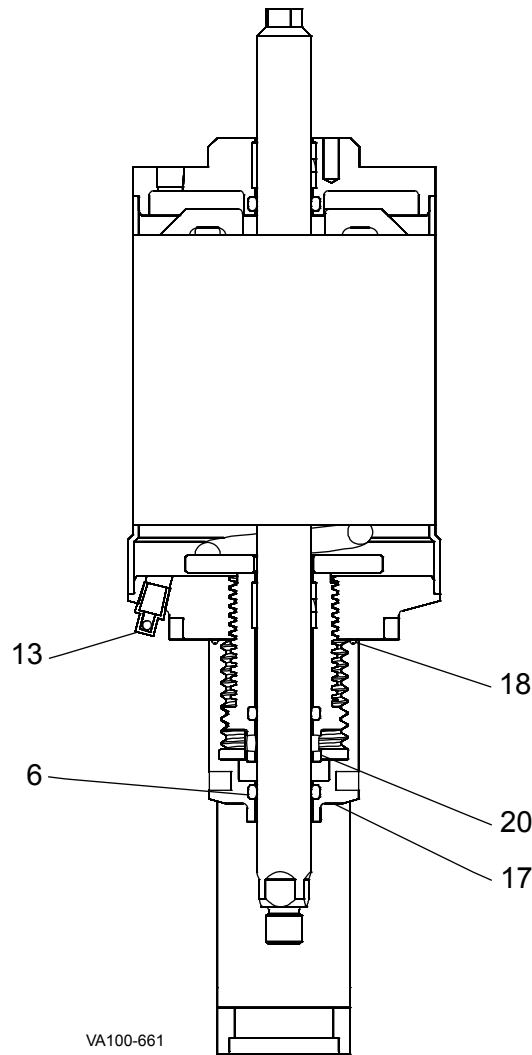

Item #	Part Description		4" (101 mm) Diameter	5" (127 mm) Diameter	6" (152 mm) Diameter
* 6	O-ring	Nitrile	N70210	N70210	N70210
13	Vent Plug		3023957+	3023957+	3023957+
17	Locknut, Cover		124058+	124058+	124058+
* 18	O-ring	Nitrile	N70032	N70032	N70032
20	Screw, Adjusting		124057+	124057+	124057+
* Recommended Spare Parts					PL5027-CH78

Maintenance Free Actuator

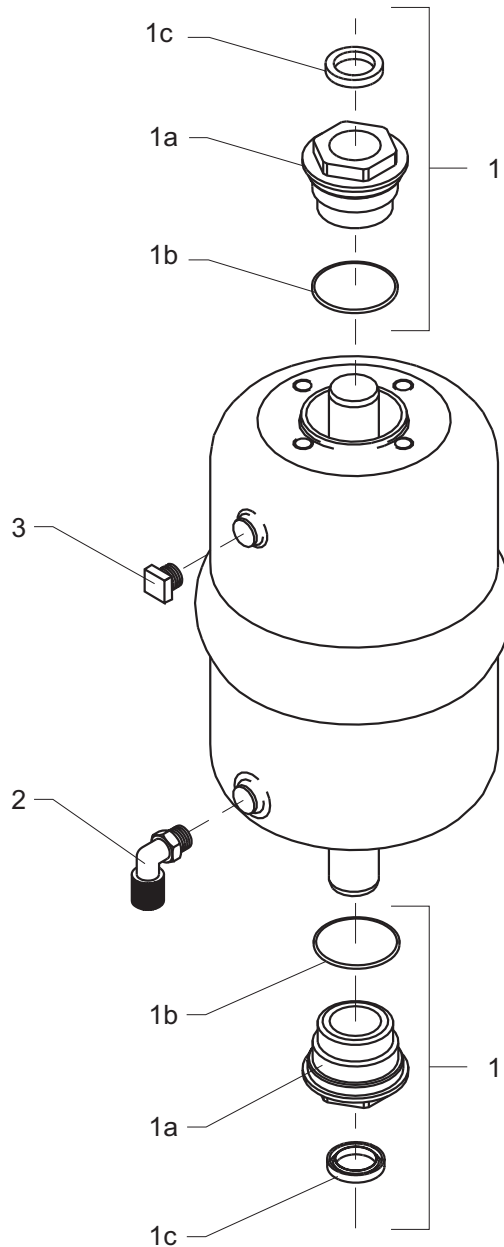

VA100-772

Item #	Part Description	A Size (74 mm)	B Size (110 mm)	C Size (165 mm)
-	Complete Actuator Assembly - Air to Spring *	M18HP816307	M18HP816308	M18HP816309
-	Complete Actuator Assembly - Air to Air **	M18AP818163	M18AP818164	M18AP818165
1	Seal Bearing (includes 1a, 1b, and 1c below)	H204256	H204256	H204256
1a	Seal Screw	H170200	H170200	H170200
1b	V-Seal	H171060	H171060	H171060
1c	O-Ring	H171059	H171059	H171059
2	Air Fitting	M568SS066A	M568SS066A	M568SS066A
3	Vent Plug	H16218	H16218	H16218

Notes

- * Air to Spring actuator requires (2) Seal Bearings, (1) Air Fitting and (1) Vent Plug
- ** Air to Air actuator requires (2) Seal Bearings and (2) Air Fittings

PL5027-CH186

Maintenance Free Actuator Cap

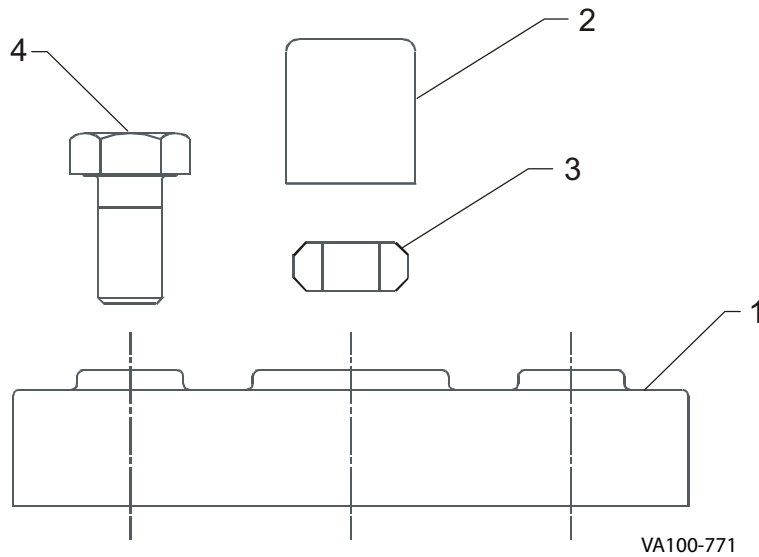

Item #	Part Description	A Size (74 mm)	B Size (110 mm)	C Size (165 mm)
-	Cap Assembly Complete *	18MB816568	18MB816503	18MB816503
1	Cover Plate	18HP816649	18HP816333	18HP816333
2	Cap	589P800276	589P800276	589P800276
3	Jam Nut	H79298	H79298	H79298
4	Screw	521SR238FB	521SR238FB	521SR238FB

Notes

PL5027-CH187

* Cap Assembly Complete includes (1) Cover Plate, (1) Jam Nut & (4) Screws

Hand Lock Manual Handle

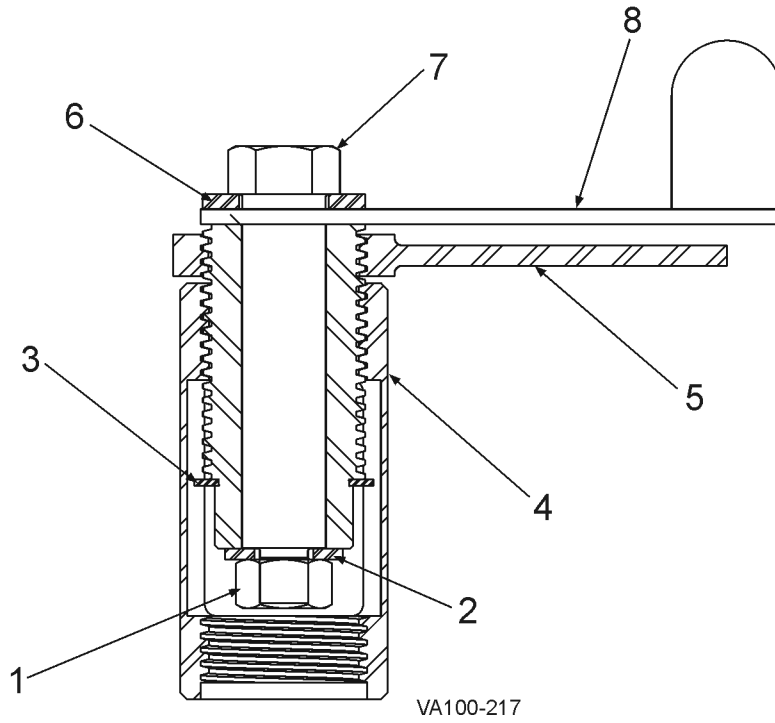

Item #	Part Description	Part No.	Note
	Actuator Assembly	105167+	
1	Hex Nut	36-54	1
2	Plane Washer	43-31	
3	Retaining Ring	2104600+	
4	Nut-Adjusting	2098700+	
5	Locknut with Handle	36-50	
6	Plain Washer	43-55	
7	Stem - Manual Actuator	105168+	
8	Adjusting Screw Assembly	105170+	

PL5027-CH39

Notes

1. The hex nut is only used for shipping. The hex nut is not used when the actuator is installed on a valve.

Hand Lock Long Stroke Manual Handle

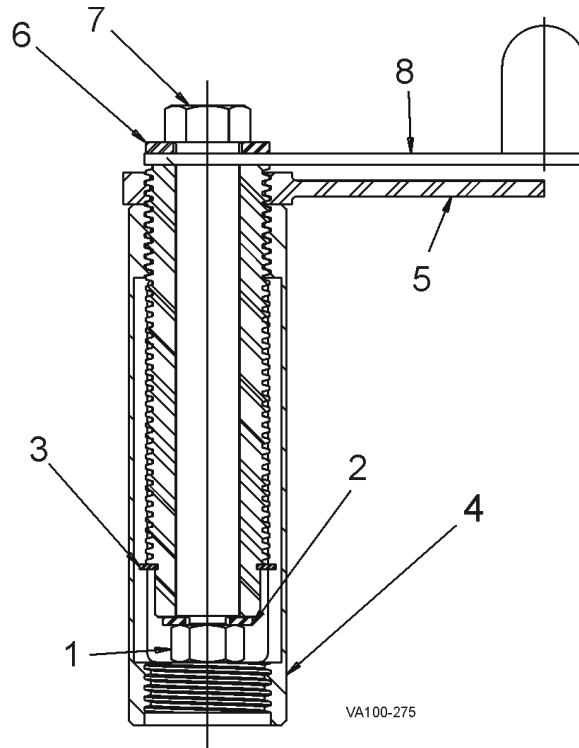

Item #	Part Description	Long Stroke Part No.	Extra Long Stroke Part No.	Note
	Actuator Assembly	112100+	121914+	
1	Hex Nut	36-54	36-54	1
2	Plane Washer	43-31	43-31	
3	Retaining Ring	2104600+	2104600+	
4	Nut-Adjusting	112101+	121916+	
5	Locknut with Handle	36-50	36-50	
6	Plain Washer	43-55	43-55	
7	Stem - Manual Actuator	110299+	121915+	
8	Adjusting Screw Assembly	112098+	121917+	

PL5027-CH40

Notes

1. The hex nut is only used for shipping. The hex nut is not used when the actuator is installed on a valve.

Micrometer Handle

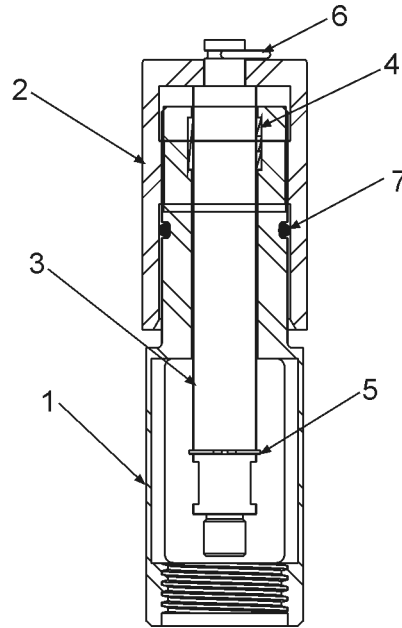

VA100-218

Item #	Part Description	Part No.
	Actuator Assembly	112884+
1	Yoke	112881+
2	Handle	112882+
3	Stem	112883+
4	Bearing	102757+
5	Retaining Ring	113163+
6	Clip	65-1
7	O-Ring, PTFE Coated	9-40

PL5027-CH41

Notes

1. When the micrometer handle assembly is ordered as a loose component, a vernier scale is not acid-etched on the handle and body.

Installation Tools

Tef-Flow™ P Tools

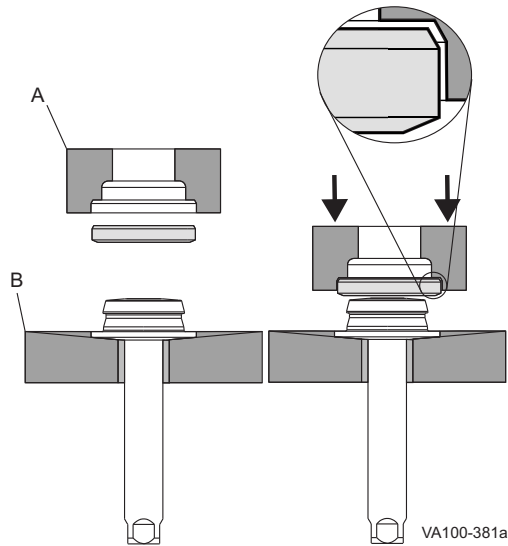

Tef-Flow™ P Installation tools

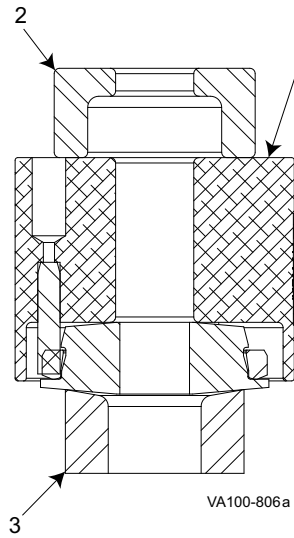

Tef-Flow™ P Removal tools

Tef-Flow™ P Tool Kits	Part No.	Notes: Does not apply to W61Y
Installation Tool Kit	135036+	Includes all items listed under "Installation"
Removal Tool Kit	133470+	Includes all items listed under "Removal"

Tef-Flow™ P Tools		Valve Size (Except for W61Y)					
		1"	1-1/2"	2"	2-1/2"	3"	4"
Installation:							
A	Seat Installation Tool	115654+	115655+	115656+	115657+	115658+	117955+
B	Install Base Tool	115653+					
Removal:							
1	Seat Removal Tool	133476+	133477+	133478+	133479+	133480+	N/A
2	Puck	132900+					
3	Install Base Tool, Upper Stem Insert	131301+					

Tef-Flow™ P Tools		W61Y		
		2-1/2"	3"	4"
Installation:				
A	Seat Installation Tool	118903+	118904+	118905+
B	Install Base Tool	118902+		
Removal:				
1	Seat Removal Tool	POA	POA	POA
2	Puck	POA	POA	POA
3	Install Base Tool, Upper Stem Insert	POA	POA	POA

PL5027-CH66

Tri-Ring Tool

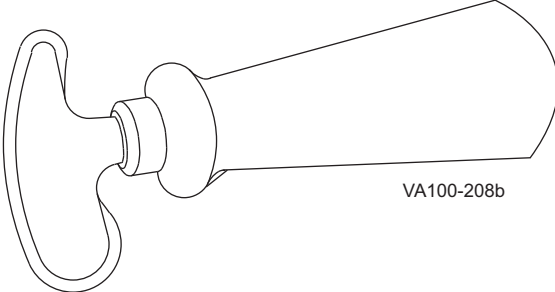

VA100-208b

Tri Ring Tool	102797+
	PL5027-CH85

Troubleshooting

PROBLEM	POSSIBLE CAUSE	SUGGESTED ACTION
Leakage		
Leakage from inside port with valve closed	Seat ring failure	Replace seat rings.
	Debris trapped in valve seats	Remove valve from service. Inspect and replace seat as needed.
	Seat ring not on valve body seat	Check actuator for function.
	Stem loose	Tighten actuator stems. Tighten valve stem to actuator stem in yoke.
	Actuator loose at adapter	Turn actuator to tighten when valve is open (W61,W63) or partly open (W62, W65).
Leakage around yoke	Internal stem adapter o-ring failure	Replace o-ring.
	External body adapter o-ring failure	Replace o-ring.
Operation		
Valve fails to open	Air pressure too low	For 4" (101 mm), 5" (127 mm) and 6" (152 mm) light spring actuators, set air pressure to 60 psi (4 bar). For 6" (152 mm) standard spring actuators, set air pressure to 80 psi (6 bar).
	Control failure	Check control sequence. Check control wiring and power source.
Valve fails to close	Control failure	Check control sequence. Check air supply. Check for loose stems. Check control wiring and power source.
	Debris trapped in valve seat	Remove valve from service. Inspect and replace seat as needed.
Actuator moves when valve opens	Clamp loose	Tighten clamp with valve open.
	Yoke loose	Tighten yoke to adapter by turning actuator.
Slow valve operation	Air not exhausting fast enough	Install quick exhaust. Move solenoid closer to valve or install in control top.
	Valve not opening fast enough	Use a bigger diameter air line.

Electrical

For control top information, please refer to publication 95-03083. For additional product information, please see our web site at www.spxflow.com/en/waukesha-cherry-burrell/resources/product-literature.

Notes

W60 and W80 Series Valves



SPX FLOW, Inc.

611 Sugar Creek Road

Delavan, WI 53115

P: (262) 728-1900 or (800) 252-5200

F: (262) 728-4904 or (800) 252-5012

E: wcb@spxflow.com

SPX FLOW, Inc. reserves the right to incorporate our latest design and material changes without notice or obligation.

Design features, materials of construction and dimensional data, as described in this bulletin, are provided for your information only and should not be relied upon unless confirmed in writing.

Please contact your local sales representative for product availability in your region. For more information visit www.spxflow.com.

The green ">" is a trademark of SPX FLOW, Inc.

ISSUED: 02/2016

COPYRIGHT © 2016 SPX FLOW, Inc.