



OPERATING MANUAL:  
**PUMP DRIVES**

Model Nos.

**07555-00**

**07555-05**

**07555-10**

**07555-15**

Provided by:

**Holland<sup>®</sup>**  
**APPLIED TECHNOLOGIES**

**[www.hollandapt.com](http://www.hollandapt.com)**

**Phone: 800-800-8464**

A-1299-1175  
Edition 02

© 2019 Cole-Parmer Instrument Company. All rights reserved.

**Masterflex** – Reg TM Cole-Parmer Instrument Company.

Trademarks bearing the ® symbol in this publication are registered in the U.S. and in other countries.

# **PUMP FOR LIQUIDS ORIGINAL INSTRUCTIONS**

## SAFETY PRECAUTIONS



**WARNINGS:** Remove power from the pump before attempting any maintenance.

*Remove power from the pump before any cleaning operation is started.*

*Repeatedly applying AC line power to the drive as a means of starting the pump can cause drive hardware damage and will void the warranty. Use the control inputs located on the 9 pin connector to start and stop the pump; this will dramatically reduce the current surge associated with starting the pump. Replace the power cord only with one of the same type and rating. The minimum power ratings are stated on the rear panel.*



**WARNINGS:** Tubing breakage may result in fluid being sprayed from pump. Use appropriate measures to protect operator and equipment.

*Turn Pump System off before removing or installing tubing. Fingers or loose clothing could get caught in drive mechanism.*



**CAUTIONS:** When changing flow direction, allow the pump to come to a complete stop before starting again. Failure to do so could cause permanent damage to the motor.

*Replace the fuse only with one of the same type and rating. The fuse rating and type are stated on the rear panel.*



**CAUTIONS:** To avoid electrical shock, the power cord protective grounding conductor must be connected to ground. Not for operation in wet locations as defined by EN61010-1.

*If the product is not used in a manner specified in the instructions, the protection provided by the equipment may be impaired.*

## Explanation of Symbols



**CAUTION:** Risk of Danger. Consult Operator's manual for nature of hazard and corrective actions.



**CAUTION:** Risk of crushing. Keep fingers away from rotor while pump is in operation. Stop pump before loading or unloading tubing.



**CAUTION:** Hot Surface. Do not touch.



**CAUTION:** Risk of electric shock. Consult Operator's manual for nature of hazard and corrective actions.

## **WARNING: Product Use Limitation**



**This product is not designed for, nor intended for use in patient connected applications; including, but not limited to, medical and dental use, and accordingly has not been submitted for FDA approval.**



**This product is not designed for, nor intended for use in hazardous duty areas as defined by ATEX or the NEC (National Electrical Code); including, but not limited to use with flammable liquids. Consult the factory for products suitable for these types of applications.**

## **Safety**

1. Read instructions before operating the unit.
2. Observe safety precautions at all times, especially when pumping dangerous liquids.
3. If the pump runs unusually noisy or if bunching of the tubing in the pump can be observed, make sure the tubing is clamped down tightly and/or replace it with a new piece of tubing.
4. The Pump Drives must be well-grounded at all times.
5. The Pump Drives are equipped with a current-limiting circuit that will slow the motor down if any of the following conditions exist:
  - a. Tubing that is too hard is loaded in the pump.
  - b. Incorrect tubing size or wall thickness is loaded in the pump.
  - c. Tubing is improperly loaded into the Pump Head.
6. The unit is fused and grounded to protect the operator in the event of short circuits that could be caused by liquid entering the case.



***CAUTION: Replace the fuse only with one of the same type and rating. The fuse rating and type are stated on the rear panel.***

7. The Pump Drives should not be used in outdoor or hazardous locations.

# Table of Contents

	<b>Page</b>
<b>Section 1 INTRODUCTION</b> .....	<b>1-1</b>
Variety of Pump Heads Accepted .....	1-1
<b>Section 2 INSTALLATION AND SETUP</b> .....	<b>2-1</b>
Setup and Drive Operation .....	2-1
External Start/Stop Control .....	2-3
<b>Section 3 MAINTENANCE</b> .....	<b>3-1</b>
Motor Brush Check/Replacement .....	3-1
Motor Gear and Brush Replacement .....	3-2
Fuse Replacement .....	3-3
Replacement Parts .....	3-4
Cleaning .....	3-4
<b>Section 4 ACCESSORIES</b> .....	<b>4-1</b>
<b>Section 5 SPECIFICATIONS</b> .....	<b>5-1</b>
<b>Section 6 WARRANTY, PRODUCT RETURN, and TECHNICAL ASSISTANCE</b> ..	<b>6-1</b>
Warranty .....	6-1
Product Return .....	6-2
Technical Assistance .....	6-2

# Figures

	<b>Page</b>
View of Rear Drive .....	2-2
View of Drive Front Controls .....	2-2
DB-9 Pin Connector Configuration with Wiring Scheme .....	2-3
DB-9 Pin Connector Jumper Installation .....	2-3
Motor Brush and Gear Check/Replacement .....	3-2
Fuse Replacement .....	3-3

## Section 1 Introduction

### **Variety of Pump Heads Accepted**

Mount up to 1 (600 rpm) or 2 (200 rpm) MASTERFLEX® L/S® Pump Heads and all MASTERFLEX-compatible Pump Heads.

## Section 2 Installation and Setup

### Setup and Drive Operation



**WARNINGS:** *Tubing breakage may result in fluid being sprayed from pump. Use appropriate measures to protect operator and equipment.*

**Turn Pump System off before removing or installing tubing. Fingers or loose clothing could get caught in drive mechanism.**

1. Mount Pump Head and load tubing. (See Pump Head manual.)



**CAUTION:** *To avoid electrical shock, the power cord protective grounding conductor must be connected to ground. Not for operation in wet locations as defined by EN61010-1.*

2. Check that the jumper is installed in the external start/stop connector. The drive will not run unless this is installed See figure 2-3.
3. Adjust flow rate with the 1-turn potentiometer speed control.



**CAUTION:** *When changing flow direction, allow the pump to come to a complete stop before starting again. Failure to do so could cause permanent damage to the motor.*



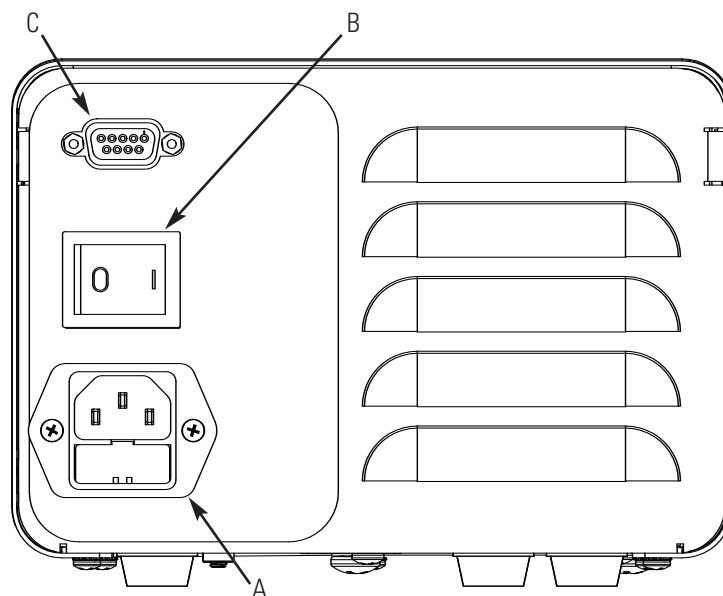

- A.** IEC Power Entry module
- B.** Power Switch
- C.** External Start/Stop Connector

**Figure 2-1.** View of Rear Drive

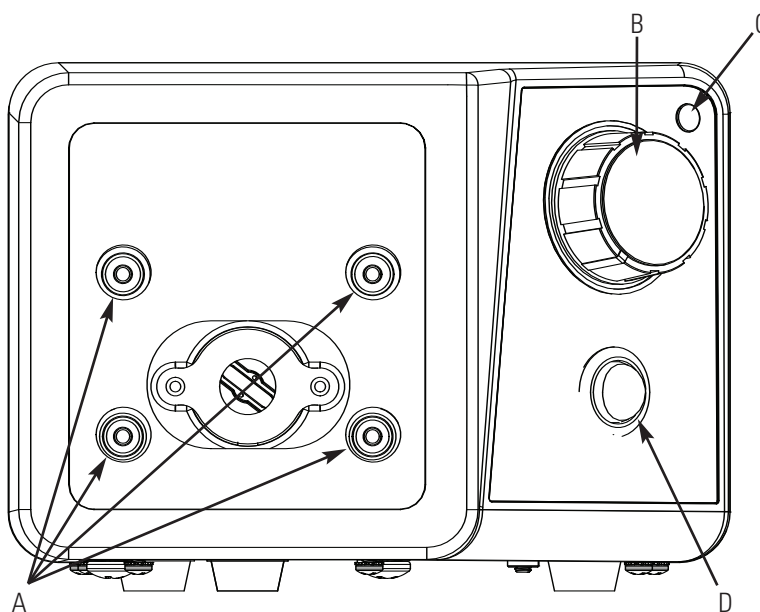

- A.** Pump Head Mounting Holes
- B.** 1-Turn Speed Control
- C.** Power Indicator
- D.** Direction Switch

**Figure 2-2.** View of Drive Front Controls

## External Start/Stop Control



**WARNING:** Repeatedly applying AC line power to the drive as a means of starting the pump can cause drive hardware damage and will void the warranty. Use the control inputs located on the 9 pin connector to start and stop the pump; this will dramatically reduce the current surge associated with starting the pump. Replace the power cord only with one of the same type and rating. The minimum power ratings are stated on the rear panel.

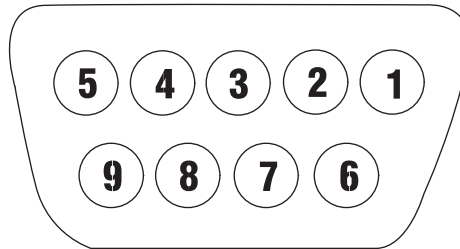

**Figure 2-3.** DB-9 Pin Connector Configuration with Wiring Scheme

Pin No. DB-9	Description
1	
2	
3	
4	
5	
6	Start/Stop
7	Start/Stop
8	
9	

**NOTE:** Jumper must be installed for pump to run.

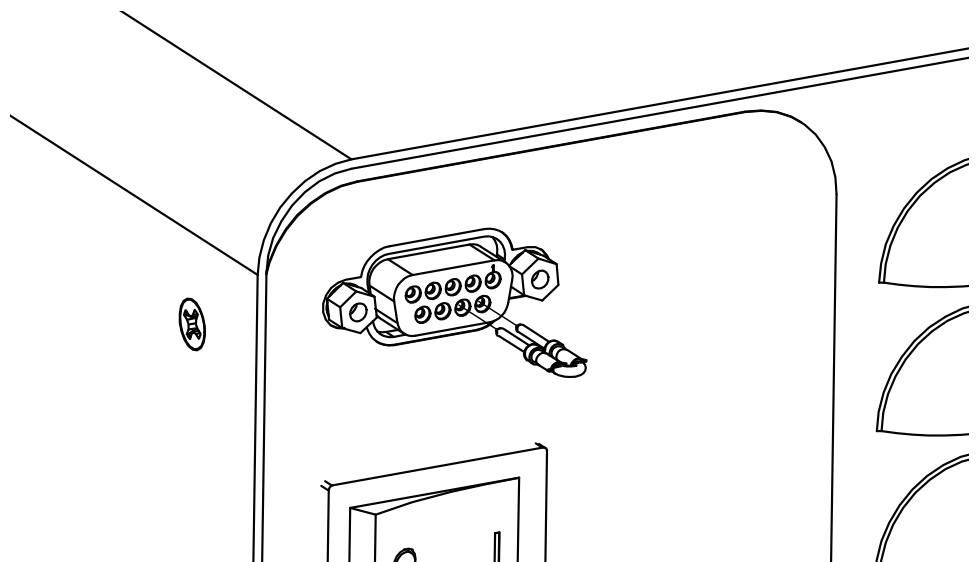

**Figure 2-4.** DB-9 Pin Connector Jumper Installation.

## Section 3 Maintenance

### Motor Brush Check/Replacement



**WARNING:** Remove power from the pump before attempting any maintenance.

1. Place the ON/OFF SWITCH in the off position.
2. Disconnect the AC power input line cord from the AC receptacle.
3. Remove the screws from each side of the housing and lift off the housing.
4. Carefully unscrew each brush cap. Withdraw the brush, and examine it for wear.

**NOTE:** Replace both brushes, if either brush is less than 7.6 mm (0.300 in) long from base to point.

5. Insert brushes and install brush cap.
6. Install housing and secure with the screws on each side.
7. Connect the AC power input line cord to the AC receptacle.

## Motor Gear and Brush Replacement

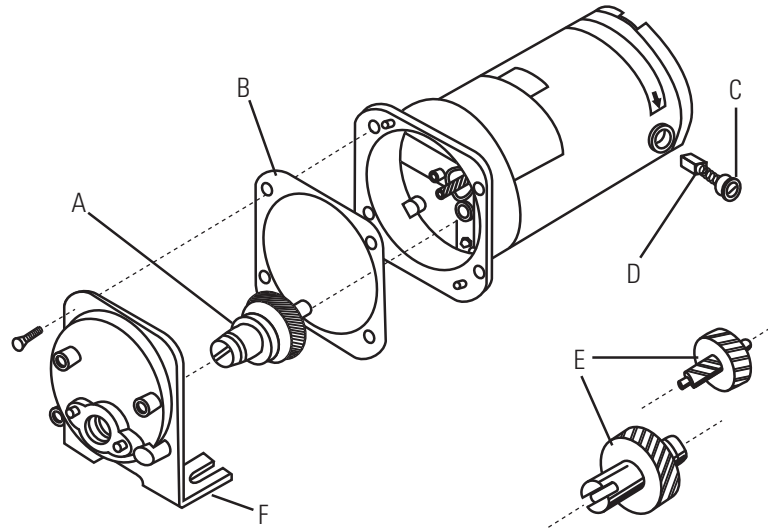

- A. 20-600 rpm gear assembly (included in service kit 07553-06)
- B. Gasket
- C. Cap
- D. Motor Brush
- E. 7-200 rpm gear set (included in service kit 07553-11)
- F. Gear case cover assembly

**Figure 3-1.** Motor Brush and Gear Check/Replacement.

# Fuse Replacement



**CAUTION:** Replace the fuse only with one of the same type and rating. The fuse rating and type are stated on the rear panel.

1. Place the power switch in the off position.
2. Disconnect the AC power input line cord from the receptacle.
3. Remove and check the fuse and replace if defective..

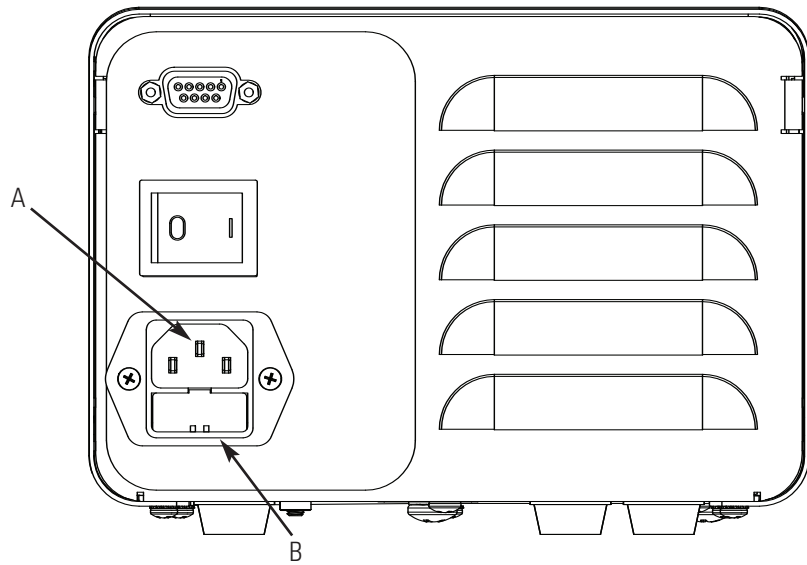

**Figure 3-2.** Fuse Replacement

Item	Description
A	IEC Power Entry Module / Line Cord
B	(5 x 20 mm) Fuse – Do Not Substitute

## Replacement Parts

Description	Part Number
Gear Service Kit (600 rpm)	07553-06
Gear Only (600 rpm)	07553-09
Gear Service Kit (200 rpm)	07553-11
Brushes (set of 2)	07520-06
Jumper Kit (set of 2)	07555-90
Fuse (07555-05, 15) T1.0A 250V; 4 × 20 mm	77500-58
Fuse (07555-00, -10) T2.0A 250V; 5 × 20 mm	07555-92

## Cleaning



**WARNING: Remove power from the pump before any cleaning operation is started.**

Keep the drive enclosure clean with mild detergents. Do not immerse or use excessive fluid when cleaning.

## Section 4 Accessories

<b>Description</b>	<b>Part Number</b>
Footswitch with 6 ft. DB-9 male connector	77595-35
Handheld Remote Controller	07528-80
DB-9 External Control Connector	07595-45
DB-9 Remote Control Cable, 25 ft.	07595-47

## Section 5 Specifications

### Output:

Speed:

600 rpm models 20 to 600 rpm

200 rpm models 7 to 200 rpm

Torque output, Maximum:

600 rpm models 90 oz-in (13 kg•cm), 270 oz-in Starting

200 rpm models 180 oz-in (26 kg•cm), 540 oz-in Starting

Speed regulation:

All models Line  $\pm 2\%$  F.S.

Load  $\pm 3\%$  F.S.

Drift  $\pm 10\%$  F.S.

### Input:

Operating Voltage/Frequency: 1.4A @ 115 Vrms 50/60 Hz,

0.7A @ 230 Vrms 50/60 Hz

### External Inputs:

START/STOP Dry Contact closure

### Construction:

Dimensions (L x W x H): 9.09 in x 7.23 in x 5.29 in  
(231 x 184 x 134.5 mm)

Weight: 9.46 lbs. (4.26 kg)

Enclosure Rating: IP 22 per IEC 60529



**Environment:**

Temperature, Operating: All models	0° to 40°C (32° to 104°F)
Temperature, Storage: All models	-25° to 65°C (-13° to 149°F)
Humidity (non-condensing): All models	10% to 90%
Altitude: All models	Less than 2000 m
Pollution Degree: All models	Pollution Degree 3 (Indoor use -- Sheltered locations)
Chemical Resistance:	Powder coated steel enclosure and cover, ABS plastic and vinyl

**Compliance:**

Certified to ANSI/UL  
61010-1 3rd Edition  
and CSA C22.2  
No. 61010-1-12  
(For CE Mark):  
EN61010-1 (EU Low Voltage Directive)  
and EN61326-1 (EU EMC Directive)

## Section 6 Warranty, Product Return and Technical Assistance

### Warranty

*Use only MASTERFLEX precision tubing with MASTERFLEX pumps to ensure optimum performance. Use of other tubing may void applicable warranties.*

This product is warranted against defects in material or workmanship, and at the option of the manufacturer or distributor, any defective product will be repaired or replaced at no charge, or the purchase price will be refunded to the purchaser, provided that: (a) the warranty claim is made in writing within the period of time specified on the warranty card, (b) proof of purchase by bill of sale or receipted invoice is submitted concurrently with the claim and shows that the product is within the applicable warranty period, and (c) the purchaser complies with procedures for returns set forth in the general terms and conditions contained in the manufacturer's or distributor's most recent catalog.

This warranty shall not apply to: (a) defects or damage resulting from: (i) misuse of the product, (ii) use of the product in other than its normal and customary manner, (iii) accident or neglect, (iv) improper testing, operation, maintenance, service, repair, installation, or storage, (v) unauthorized alteration or modification, or (b) post-expiration dated materials.

THIS WARRANTY IS THE EXCLUSIVE REMEDY OF THE PURCHASER, AND THE MANUFACTURER AND DISTRIBUTOR DISCLAIM ALL OTHER WARRANTIES, WHETHER EXPRESS, IMPLIED, OR STATUTORY, INCLUDING WITHOUT LIMITATION, WARRANTIES OF MERCHANTABILITY AND FITNESS FOR A PARTICULAR PURPOSE. NO EMPLOYEE, AGENT, OR REPRESENTATIVE OF THE MANUFACTURER OR DISTRIBUTOR IS AUTHORIZED TO BIND THE MANUFACTURER OR DISTRIBUTOR TO ANY OTHER WARRANTY. IN NO EVENT SHALL THE MANUFACTURER OR DISTRIBUTOR BE LIABLE FOR INCIDENTAL, INDIRECT, SPECIAL OR CONSEQUENTIAL DAMAGES.

*The warranty period for this product is two (2) years from date of purchase.*

## **Product Return**

To limit charges and delays, contact the Manufacturer or authorized seller for authorization and shipping instructions before returning the product, either within or outside of the warranty period. When returning the product, please state the reason for the return. For your protection, pack the product carefully and insure it against possible damage or loss. Any damages resulting from improper packaging are your responsibility.

## **Technical Assistance**

If you have any questions about the use of this product, contact the Manufacturer or authorized seller.

*Provided by:*



**US & Canada only**

Toll Free 1-800-MASTERFLEX | 1-800-637-3739

**Outside US & Canada**

1-847-549-7600 | 1-847-381-7050

**\*EN809 manufactured by:**

Cole-Parmer Instrument Company  
28W092 Commercial Avenue, Barrington, IL 60010  
techinfo@masterflex.com | [www.masterflex.com](http://www.masterflex.com)