

200 Series

CENTRIFUGAL PUMP

FORM NO.: 95-03009 REVISION: 12/2018

READ AND UNDERSTAND THIS MANUAL PRIOR TO OPERATING OR SERVICING THIS PRODUCT.



Provided by:

Holland[®]
APPLIED TECHNOLOGIES

www.hollandapt.com

Phone: 800-800-8464

➤ **Waukesha Cherry-Burrell**[®]

SPX FLOW, Inc.
611 Sugar Creek Road
Delavan, WI 53115 USA

Tel: (800) 252-5200 or (262) 728-1900
Fax: (800) 252-5012 or (262) 728-4904

E-mail: wcb@spxflow.com
Web site: www.spxflow.com

Information contained in this manual is subject to change without notice and does not represent a commitment on the part of SPX FLOW, Inc. No part of this manual may be reproduced or transmitted in any form or by any means, electronic or mechanical, including photocopying and recording, for any purpose, without the express written permission of SPX FLOW, Inc.

Copyright © 2018 SPX FLOW, Inc.
All Rights Reserved.

Revision Date: 12/2018

Publication: 95-03009

Warranty	5
Shipping Damage or Loss	5
Warranty Claim	5
Safety	6
Care of Component Materials	7
Stainless Steel Corrosion	7
Elastomer Seal Replacement Following Passivation	7
Introduction	8
Receiving Your Pump	8
Receiving and Inspection	8
Pump Characteristics	8
200 Series Pedestal Mount Arrangements	9
Style C Arrangement	9
Style L Arrangement	9
Style B Arrangement	9
Style D Arrangement	9
Base Options	9
Operating Parameters	10
Dimensions	11
Centrifugal 200 Series Pump and Pedestal Weights	14
Installation	16
Pump Location	16
Pump Leveling	16
Supply and Discharge Piping/Valves	16
Installations That May Cause Operation Problems	18
Electrical Connections	18
Flush Seal Option	19
Type 1 with Cascade	19
Type 4 Seal (Double mechanical with flush)	19
Before First Startup	20
Clean Pump and Piping	20
Cleaning Safety Procedures	20
Manual Cleaning	20
Cleaning-In-Place (CIP)	20
Preliminary Test Run	21
Check For Possible Motor Overload Conditions	21
Operation	22
Important Safety Information	22
Starting the Pump	22
Priming the Pump/Stopping the Pump	23
Priming the Pump with the Feed Source Above Pump Level	23
Priming the Pump with the Feed Source Below Pump Level (not recommended) ...	23
Stopping the Pump	23
Maintenance	24
Important Safety Information	24
Scheduled Maintenance	24
Routine Maintenance	24
Disassembly of Pump with a Type 1 Seal	25
Inspect Parts	26
Assembly of Pump with a Type 1 Seal	27
Backplate Assembly	27
Backplate/Impeller Assembly	27
Disassembly of Pump with a Type 4 Double Seal	29
Assembly of Pump with Type 4 Seal	31
Disassembly of Modular Base-Mounted Pumps	33
Disassembling the Outer Seal Assemblies	34
Assembling the Outer Seal Assemblies	34

Pre-assembled (Cartridge) Seals	35
Disassembly of a Pump with Pre-assembled (Cartridge) Seals	35
Assembly of a Pump with Pre-assembled (Cartridge) seals	36
Pedestal Base-Mounted Pump Housing Lubrication	38
Pump Alignment	38
Checking Angular Alignment	38
Checking Parallel Alignment	38
Servicing the Electric Motor	39
General Service Information	39
Motor Lubrication Instructions	39
Replacing the Impeller stud and nut	39
Standard Seal Dimensions	40
Cartridge Seal Identification	41
Parts Lists	42
2045 Pump Parts	42
2065LV - 2065 - 2065HV Pump Parts	44
2075 Pump Parts	46
2085LV - 2085 Pump Parts	48
2105 Pump Parts	50
Type 1 Seal Components and Common Parts	52
Type 4 Seal Components and Common Parts	54
Type 1 Seal Kits	56
Type 4 Seal Kits	57
Style “C” Small Bore Pedestal Mount Parts	58
Style “C” Large Bore Pedestal Mount Parts	60
Motor Mounts	62
Motor Shaft Shims	62
Troubleshooting	63

Warranty

LIMITED WARRANTY: Unless otherwise mutually agreed to in writing, (a) SPX FLOW US, LLC (SPX FLOW) goods, auxiliaries and parts thereof are warranted to the Buyer against defective workmanship and material for a period of twelve (12) months from date of installation or eighteen (18) months from date of delivery, whichever expires first, and (b) SPX FLOW services are warranted to Buyer to have been performed in a workman-like manner for a period of ninety (90) days from the date of performance. If the goods or services do not conform to the warranty stated above, then as Buyer's sole remedy, SPX FLOW shall, at SPX FLOW's option, either repair or replace the defective goods or re-perform defective services. If Buyer makes a warranty claim to SPX FLOW and no actual defect is subsequently found, Buyer shall reimburse SPX FLOW for all reasonable costs which SPX FLOW incurs in connection with the alleged defect. Third party goods furnished by SPX FLOW will be repaired or replaced as Buyer's sole remedy, but only to the extent provided in and honored by the original manufacturer's warranty. Unless otherwise agreed to in writing, SPX FLOW shall not be liable for breach of warranty or otherwise in any manner whatsoever for: (i) normal wear and tear; (ii) corrosion, abrasion or erosion; (iii) any good or services which, following delivery or performance by SPX FLOW, has been subjected to accident, abuse, misapplication, improper repair, alteration (including modifications or repairs by Buyer, the end customer or third parties other than SPX FLOW), improper installation or maintenance, neglect, or excessive operating conditions; (iv) defects resulting from Buyer's specifications or designs or those of Buyer's contractors or subcontractors other than SPX FLOW; or (v) defects resulting from the manufacture, distribution, promotion or sale of Buyer's products; (vi) damage resulting from the combination, operation or use with equipment, products, hardware, software, firmware, systems or data not provided by SPX FLOW, if such damage or harm would have been avoided in the absence of such combination, operation or use; or (vii) Buyer's use of the goods in any manner inconsistent with SPX FLOW's written materials regarding the use of such product. In addition, the foregoing warranty shall not include any labor, dismantling, re-installation, transportation or access costs, or other expense associated with the repair or replacement of SPX FLOW goods. THE WARRANTIES CONTAINED HEREIN ARE THE SOLE AND EXCLUSIVE WARRANTIES AVAILABLE TO BUYER AND SPX FLOW HEREBY DISCLAIMS ANY OTHER WARRANTIES, EXPRESS OR IMPLIED, INCLUDING WITHOUT LIMITATION THE IMPLIED WARRANTIES OF MERCHANTABILITY AND FITNESS FOR A PARTICULAR PURPOSE, ANY PERFORMANCE OR PROCESS OUTCOME DESIRED BY THE BUYER AND NOT SPECIFICALLY AGREED TO BY SPX FLOW. THE FOREGOING REPAIR, REPLACEMENT AND REPERFORMANCE OBLIGATIONS STATE SPX FLOW'S ENTIRE AND EXCLUSIVE LIABILITY AND BUYER'S EXCLUSIVE REMEDY FOR ANY CLAIM IN CONNECTION WITH THE SALE AND FURNISHING OF SERVICES, GOODS OR PARTS, THEIR DESIGN, SUITABILITY FOR USE, INSTALLATION OR OPERATIONS.

Shipping Damage or Loss

If equipment is damaged or lost in transit, file a claim at once with the delivering carrier. The carrier has a signed Bill of Lading acknowledging that the shipment has been received from SPX FLOW in good condition. SPX FLOW is not responsible for the collection of claims or replacement of materials due to transit shortage or damages.

Warranty Claim

Warranty claims must have a **Returned Material Authorization (RMA)** from the Seller or returns will not be accepted. Contact 800-252-5200 or 262-728-1900.

Claims for shortages or other errors must be made in writing to Seller within ten (10) days after delivery. This does not include transit shortage or damages. Failure to give such notice shall constitute acceptance and waiver of all such claims by Buyer.

Safety

READ AND UNDERSTAND THIS MANUAL PRIOR TO INSTALLING, OPERATING, OR SERVICING THIS EQUIPMENT

SPX FLOW recommends users of our equipment and designs follow the latest Industrial Safety Standards. At a minimum, these should include the industrial safety requirements established by:

1. Occupational Safety and Health Administration (OSHA)
2. National Fire Protection Association (NFPA)
3. National Electrical Code (NEC)
4. American National Standards Institute (ANSI)

⚠ WARNING

Severe injury or death can result from electrical shock, burn, or unintended actuation of equipment. Recommended practice is to disconnect and lockout industrial equipment from power sources, and release stored energy, if present. Refer to the National Fire Protection Association Standard No. NFPA70E, Part II and (as applicable) OSHA rules for Control of Hazardous Energy Sources (Lockout-Tagout) and OSHA Electrical Safety Related Work Practices, including procedural requirements for:

- Lockout-tagout
- Personnel qualifications and training requirements
- When it is not feasible to de-energize and lockout-tagout electrical circuits and equipment before working on or near exposed circuit parts

Before putting SPXFLOW equipment into operation, the operator shall analyze the application for all foreseeable risks, their likelihood to occur and the potential consequences of the identified risks as per ISO 31000 and ISO/IEC 31010 in their actual current version.

Locking and Interlocking Devices: These devices should be checked for proper working condition and capability of performing their intended functions. Make replacements only with the original equipment manufacturer's OEM renewal parts or kits. Adjust or repair in accordance with the manufacturer's instructions.

Periodic Inspection: Equipment should be inspected periodically. Inspection intervals should be based on environmental and operating conditions and adjusted as indicated by experience. At a minimum, an initial inspection within 3 to 4 months after installation is recommended. Inspection of the electrical control systems should meet the recommendations as specified in the National Electrical Manufacturers Association (NEMA) Standard No. ICS 1.3, Preventative Maintenance of Industrial Control and Systems Equipment, for the general guidelines for setting-up a periodic maintenance program.

Replacement Equipment: Use only replacement parts and devices recommended by the manufacturer to maintain the integrity of the equipment. Make sure the parts are properly matched to the equipment series, model, serial number, and revision level of the equipment.

Warnings and cautions are provided in this manual to help avoid serious injury and/or possible damage to equipment:

⚠ DANGER

marked with a stop sign.

Immediate hazards which WILL result in severe personal injury or death.

⚠ WARNING

marked with a warning triangle.

Hazards or unsafe practices which COULD result in severe personal injury or death.

⚠ CAUTION

marked with a warning triangle.

Hazards or unsafe practices which COULD result in minor personal injury or product or property damage.

Care of Component Materials

NOTE: SPX FLOW recommends the use of an FDA-approved anti-seize compound on all threaded connections.

⚠ WARNING

Failure to comply with the Care of Component Materials could lead to bodily injury.

Stainless Steel Corrosion

Corrosion resistance is greatest when a layer of oxide film is formed on the surface of stainless steel. If film is disturbed or destroyed, stainless steel becomes much less resistant to corrosion and may rust, pit or crack.

Corrosion pitting, rusting and stress cracks may occur due to chemical attack. Use only cleaning chemicals specified by a reputable chemical manufacturer for use with stainless steel. Do not use excessive concentrations, temperatures or exposure times. Avoid contact with highly corrosive acids such as hydrofluoric, hydrochloric or sulfuric. Also avoid prolonged contact with chloride-containing chemicals, especially in presence of acid. If chlorine-based sanitizers are used, such as sodium hypochlorite (bleach), do not exceed concentrations of 150 ppm available chlorine, do not exceed contact time of 20 minutes, and do not exceed temperatures of 104°F (40°C).

Corrosion discoloration, deposits or pitting may occur under product deposits or under gaskets. Keep surfaces clean, including those under gaskets or in grooves or tight corners. Clean immediately after use. Do not allow equipment to set idle, exposed to air with accumulated foreign material on the surface.

Corrosion pitting may occur when stray electrical currents come in contact with moist stainless steel. Ensure all electrical devices connected to the equipment are correctly grounded.

Elastomer Seal Replacement Following Passivation

Passivation chemicals can damage product contact areas of this equipment. Elastomers (rubber components) are most likely to be affected. Always inspect all elastomer seals after passivation is completed. Replace any seals showing signs of chemical attack. Indications may include swelling, cracks, loss of elasticity or any other noticeable changes when compared with new components.

Introduction

NOTE: Maintenance procedures in this manual do not cover aseptic or high pressure pump applications.

Receiving Your Pump

All ports are covered at the factory to keep out foreign objects during transit. If the covers are missing or damaged, thoroughly inspect the fluid head, by removing the pump cover (if applicable). Be sure that the pumping head is clean and free of foreign material before rotating the shaft. Each Waukesha Cherry-Burrell brand pump is shipped completely assembled and lubricated. Make sure you review “Operation” on page 22 before operating your pump.

Receiving and Inspection

SPX FLOW equipment is inspected prior to shipment. When leaving the factory, it is well-crated for normal transportation procedures. SPX FLOW cannot, however, guarantee safe arrival. Therefore, upon receipt of this equipment, check the received items against the packing list for damaged or missing parts. Check the packing material thoroughly for small parts.

Visually inspect for damage or loss. Immediately take pictures and document any damage; report any damage or loss to the delivery carrier while present. See “Shipping Damage or Loss” on page 5.

Pump Characteristics

The Waukesha Cherry-Burrell brand 200 Series Pump is built for extremely durable service. The casing, backplate and impeller/stub shaft are 316L stainless steel for extra strength and resistance to line shock and corrosion.

The casing is clamped to the motor adapter bracket (close coupled) or bearing housing (base mount) for easy disassembly, while permitting 360 degree rotation of the discharge port.

All seal components are interchangeable between models. All seal assemblies use an externally-mounted, balanced rotary seal for longer seal life and better sealing capability. The stationary seal face is reversible and replaceable.

200 Series pumps are designed for a broad range of sanitary and industrial applications. Sanitary models are designed for clean-in-place and meet U.S.D.A. and 3-A Standards.

200 Series Pedestal Mount Arrangements

The Waukesha Cherry-Burrell brand 200 Series Pedestal Base Mounted Centrifugal Pump design is available in 4 arrangements to provide the flexibility to meet various needs:

Style C Arrangement

The style C arrangement includes the bearing housing (2), coupling, coupling guard (1), pedestal stand (3), and base (4), for use with T-frame motors with feet. The pump and motor are mounted and supported independently. (Figure 1).

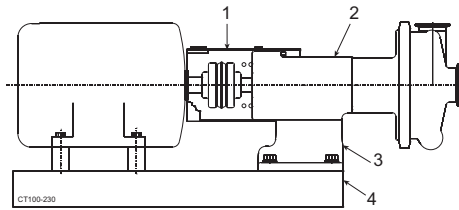

Figure 1 - Style C

Style L Arrangement

The style L arrangement includes the bearing housing (2), coupling guard (1), and pedestal stand (3), for use with T-frame motors. (Figure 2).

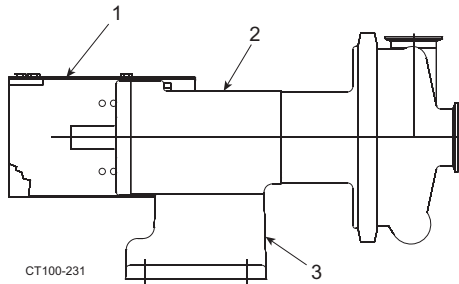

Figure 2 - Style L

Style B Arrangement

The style B arrangement includes the bearing housing (2), motor adapter (5), coupling cover, coupling (1), pedestal stand (3), and base (4), for use with NEMA C-Face motors with feet. The pump and motor are mounted and supported independently. (Figure 3).

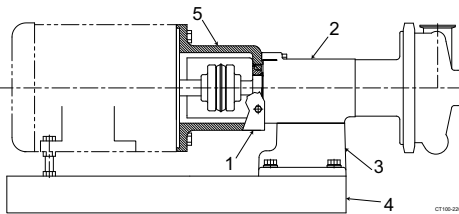

Figure 3 - Style B

Style D Arrangement

The style D arrangement includes the bearing housing (2), motor adapter (5), and coupling cover (1), for use with NEMA C-Face motors. (Figure 4).

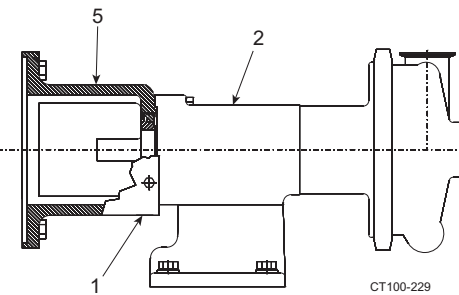

Figure 4 - Style D

Base Options

- Carbon steel channel base
- Stainless steel plate base
- Carbon steel plate base
- Custom

Operating Parameters**Viscosity**

Up to 500 CPS

Differential Pressure

Up to 340 Feet (100 Meters)

Temperature

Up to 400°F (204°C) (limited by elastomer selection)

Nominal Speeds

1450 or 2900 RPM - 50HZ

1750 or 3500 RPM - 60HZ

Table 1: Sizes, Capacities

Model	Inlet size		Outlet Size		Max. Impeller size		Max Capacity				Maximum Head			
							1750 RPM		3500 RPM		1750 RPM		3500 RPM	
	in	mm	in.	mm	in.	mm	gpm	m ³ /hr.	gpm	m ³ /hr.	ft.	m	ft.	m
2045	1.5	38	1.5	38	4.5	114	97	22	190	43	22	7	88	27
	2.0	31	1.5	38	4.5	114	97	22	190	43	22	7	88	27
2065LV	1.5	38	1.5	38	6.5	165	100	23	200	45	44	13	180	55
	2.0	51	1.5	38	6.5	165	100	23	200	45	44	13	180	55
2065	2.5	65	1.5	38	6.5	165	100	23	200	45	44	13	180	55
	2.5	65	2.0	51	6.5	165	245	56	400	91	47	14	190	58
2065HV	3.0	76	2.0	51	6.5	165	370	84	500	114	50	15	200	61
2075	3.0	76	1.5	38	8.6875	218	125	28	300	68	80	24	320	98
2085LV	2.0	51	1.5	38	8.5	216	70	16	145	33	81	24	330	100
2085	3.0	76	2.5	64	8.6875	218	480	109	840	191	85	26	342	104
	4.0	102	2.5	64	8.6875	218	480	109	840	191	85	26	342	104
2105	4.0	102	4.0	102	10.5	267	1400	318	N/A	N/A	133	41	N/A	N/A
	6.0	152	4.0	102	10.5	267	1400	318	N/A	N/A	133	41	N/A	N/A

Dimensions

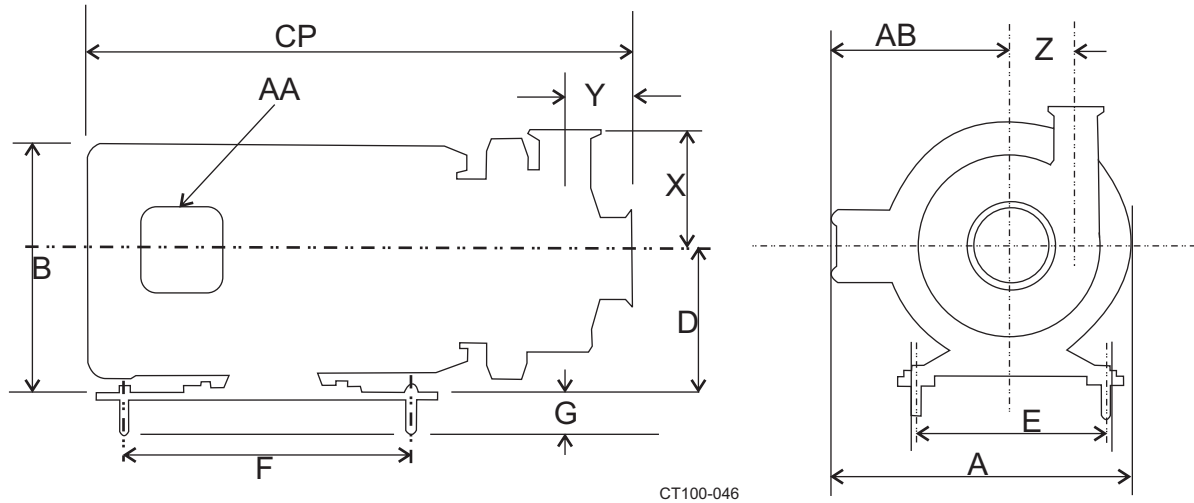

Figure 5 - Dimensions

NOTE: Motor dimensions may vary depending on the motor manufacturer. All dimensions listed as inch (mm).

Table 2: Table of Dimensions

Motor Frame	Dimension CP by Pump Model, Inlet x Outlet									
	2045 All	2065LV All	2065 2.5x2	2065HV 3x2	2085LV 2x1.5	2075 2x1.5	2085 3x2.5	2085 4x2-1/2	2105 4x4	2105 6x4
145JM	18.94 (481)	16.35 (415)	16.94 (430)	17.04 (433)	16.16 (410)	16.16 (410)	17.50 (445)	17.05 (433)	--	--
182JM	21.81 (554)	19.66 (500)	20.25 (514)	20.35 (517)	18.09 (459)	18.09 (459)	19.43 (494)	18.96 (482)	--	--
184JM	--	19.66 (500)	20.25 (514)	20.35 (517)	18.09 (459)	18.09 (459)	19.43 (494)	18.96 (482)	25.13 (638)	25.16 (639)
213JM	--	21.91 (557)	22.50 (572)	22.60 (574)	21.72 (552)	21.72 (552)	23.05 (585)	22.55 (573)	23.88 (607)	23.91 (607)
215JM	--	21.91 (557)	22.50 (572)	22.60 (574)	21.72 (552)	21.72 (552)	23.05 (585)	22.55 (573)	26.56 (675)	26.59 (675)
254JM	--	25.47 (647)	26.06 (662)	26.17 (665)	25.53 (648)	25.53 (648)	26.87 (682)	26.43 (671)	27.63 (702)	27.66 (703)
256JM	--	--	27.81 (706)	27.92 (709)	25.53 (648)	25.53 (648)	26.87 (682)	26.43 (671)	29.38 (746)	29.41 (747)
284JM	--	--	--	28.44 (722)	27.66 (703)	27.66 (703)	29.00 (737)	28.50 (724)	29.94 (760)	29.97 (761)
286JM	--	--	--	29.94 (760)	29.16 (791)	29.16 (791)	30.50 (775)	30.00 (762)	31.44 (799)	31.47 (799)
324JM	--	--	--	--	29.97 (761)	29.97 (761)	31.31 (795)	30.81 (782)	31.63 (803)	31.66 (804)
326JM	--	--	--	--	31.47 (799)	31.47 (799)	32.81 (833)	32.31 (821)	32.87 (835)	32.91 (836)

NOTE: Figure 5 dimensions are continued on page 12.

Table 3: Table of Dimensions, continued (ref. Figure 5 on page 11)

Motor Frame	A *	B *	D	AA *	AB *	F	E	G
145JM	8.56 (218)	6.87 (174)	3.5 (89)	.75 (19)	5.25 (133)	12.50 (317)	5.50 (140)	2.00 (51)
182JM	9.81 (249)	8.69 (221)	4.50 (114)	.75 (19)	5.87 (149)	12.50 (317)	7.50 (190)	
184JM	9.81 (249)	8.69 (221)	4.50 (114)	.75 (19)	5.87 (149)	12.50 (317)	7.50 (190)	
213JM	12.18 (309)	10.25 (260)	5.25 (133)	1.00 (25)	7.38 (187)	12.50 (317)	8.25 (209)	
215JM	12.18 (309)	10.25 (260)	5.25 (133)	1.00 (25)	7.38 (187)	16.0 (406)	8.25 (209)	
254JM	16.09 (409)	12.88 (327)	6.25 (159)	1.00 (25)	9.63 (224)	16.0 (406)	10.0 (254)	
256JM	16.09 (409)	12.88 (327)	6.25 (159)	1.00 (25)	9.63 (244)	25.5 (648)	10.0 (254)	
284JM	20.44 (519)	14.63 (371)	7.00 (178)	1.56 (38)	13.13 (333)	25.5 (648)	11.0 (279)	2.50 (64)
286JM	18.87 (225)	13.63 (346)	7.00 (178)	1.5 (38)	13.13 (333)	25.5 (648)	11.0 (279)	
324JM	22.35 (568)	16.5 (419)	8.00 (203)	2.00 (51)	14.13 (359)	25.5 (648)	12.5 (317)	
326JM	22.35 (568)	16.5 (419)	8.00 (203)	2.00 (51)	14.13 (359)	25.5 (648)	12.5 (317)	

NOTE: All dimensions listed as inch (mm). Dimension B applies to pumps with S-Line connections.

* Depends on motor dimension (varies per manufacturer). SPX FLOW preferred motor supplier dimensions have been given.

Table 4: Table of Dimensions, continued (ref. Figure 5 on page 11)

Model	Inlet x Outlet (inch)	X inch (mm)	Y inch (mm)	Z inch (mm)
2045	1.5 x 1.5 and 2.0 x 1.5	3.88 (98)	1.81 (46)	2.25 (57)
2065LV	1.5 x 1.5, 2.0 x 1.5, 2.5 x 1.5	4.75 (120)	1.94 (49)	3.19 (81)
2065	2.5 x 2.0	4.44 (113)	1.94 (49)	3.94 (100)
2065HV	3.0 x 2.0	4.44 (113)	1.94 (49)	3.94 (100)
2075	3.0 x 1.5	6.69 (170)	1.75 (44)	4.5 (114)
2085LV	2.0 x 1.5	6.69 (170)	1.75 (44)	4.5 (114)
2085	3.0 x 2.5	5.63 (143)	2.53 (64)	5.06 (129)
	4.0 x 2.5	5.63 (143)	2.03 (52)	5.06 (129)
2105	4.0 x 4.0	6.94 (176)	2.86 (73)	6.75 (171)
	6.0 x 4.0	6.94 (176)	2.90 (74)	6.75 (171)

NOTE: Dimensions X and Y apply to pumps with S-Line connections.

See page 10 for full inlet/outlet dimensions.

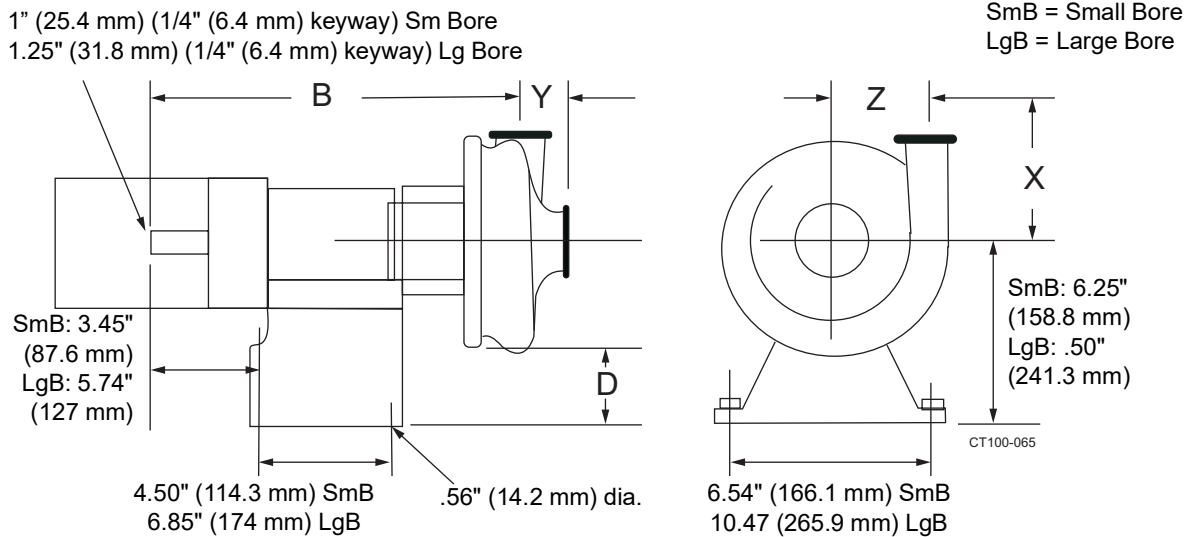

Figure 6 - Style "B" and "C" Less Baseplate

Table 5: Table of Dimensions, Style "B" and "C"

Model	B				D		X	Y	Z
	Inlet	Outlet	Sm Bore	Lg Bore	Sm Bore	Lg Bore			
P2045	1.5 (40)	1.5 (40)	16.39 (416)	--	3.0 (76)	--	3.88 (98)	1.81 (45)	2.25 (57)
	2.0 (50)	1.5 (40)	16.39 (416)	--	3.0 (76)	--	3.88 (98)	1.81 (45)	2.25 (57)
P2065LV	1.5 (40)	1.5 (40)	16.71 (224)	--	2.0 (50)	5.2 (132)	4.75 (120)	1.94 (49)	3.19 (81)
	2.0 (50)	1.5 (40)	16.71 (224)	--	2.0 (50)	5.2 (132)	4.75 (120)	1.94 (49)	3.19 (81)
	2.5 (65)	1.5 (40)	16.71 (224)	--	2.0 (50)	5.2 (132)	4.75 (120)	1.94 (49)	3.19 (81)
P2065	2.5 (65)	2.0 (50)	17.30 (439)	--	2.0 (50)	5.2 (132)	4.44 (112)	1.94 (49)	3.94 (100)
P2065HV	3.0 (75)	2.0 (50)	17.93 (455)	21.30 (541)	2.0 (50)	5.2 (132)	4.44 (112)	1.94 (49)	3.94 (100)
P2075	3.0 (75)	1.5 (40)	17.19 (436)	20.42 (581)	1.0 (25)	4.2 (106)	6.69 (176)	1.75 (44)	4.50 (114)
P2085LV	2.0 (50)	1.5 (40)	17.19 (436)	20.42 (581)	1.0 (25)	4.2 (106)	6.69 (176)	1.75 (44)	4.50 (114)
P2085	3.0 (75)	2.5 (65)	18.41 (467)	21.90 (556)	1.0 (25)	4.2 (106)	5.63 (143)	2.53 (64)	5.06 (128)
	4.0 (100)	2.5 (65)	17.91 (454)	21.40 (543)	1.0 (25)	4.2 (106)	5.63 (143)	2.03 (51)	5.06 (128)
P2105	4.0 (100)	--	--	22.57 (573)	--	3.2 (81)	6.94 (176)	2.86 (72)	6.75 (171)
	6.0 (150)	--	--	22.60 (574)	--	3.2 (81)	6.94 (176)	2.90 (73)	6.75 (171)

NOTE: Dimensions X, Y, and B apply to pumps with S-Line connections. All dimensions listed as inch (mm).

Centrifugal 200 Series Pump and Pedestal Weights

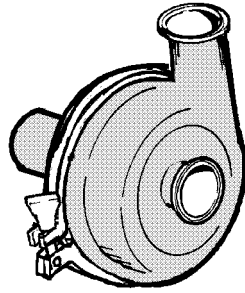

Figure 7 - Close-Coupled Pump (Less Motor and Legs)

Table 6: Close-Coupled Pump Weights (less motor and leg kit)

Motor Frame	2045 lb (kg)	2065LV lb (kg)	2065 lb (kg)	2065HV lb (kg)	2075 lb (kg)	2085LV lb (kg)	2085 lb (kg)	2105 lb (kg)
142-184JM	21 (9.5)	31 (14)	33 (14.9)	35 (15.8)	57 (25.8)	57 (25.8)	51 (23.1)	60 (27.2)
213-215JM	35 (15.8)	37 (16.7)	39 (17.6)	60 (27.2)	54 (24.4)	54 (24.4)	78 (35.3)	--
254-256JM	37 (16.7)	39 (17.6)	41 (18.5)	63 (28.5)	57 (25.8)	57 (25.8)	79 (35.8)	--
284-326JM	51 (23.1)	53 (24)	71 (32.2)	64 (29)	82 (37.1)	82 (37.1)	--	--

NOTE: Add 5 lb (2.27 kg) for pumps with double seals

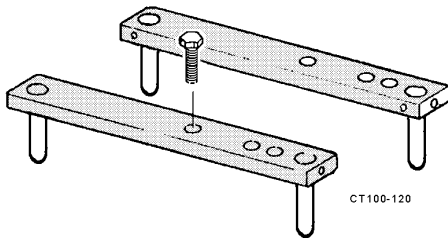

Figure 8 - Leg kit

Table 7: Add Listed Weight for Leg Kit

Motor Frame	Weight lb (kg)
142-213JM	10.5 (4.7)
215-254JM	12.5 (5.6)
254-326JM	42.5 (19.2)

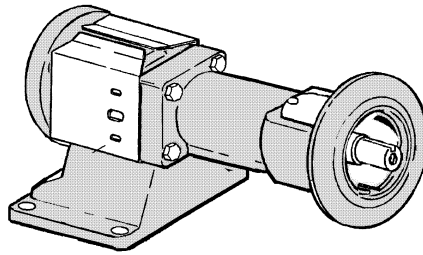

Figure 9 - Pedestal Pump (Less Base and Motor) Type B/D shown

Table 8: Pedestal Pump Weights

Pedestal	2045 lb (kg)	2065LV lb (kg)	2065 lb (kg)	2065HV lb (kg)	2075 lb (kg)	2085LV lb (kg)	2085 lb (kg)	2105 lb (kg)
Small Bore	92 (41)	106 (48)	108 (48.9)	110 (49.8)	131 (59.4)	131 (59.4)	125 (56.6)	--
Large Bore	--	--	--	--	--	--	235 (106.5)	240 (108.8)

Table 9: Add Listed Weight for Base

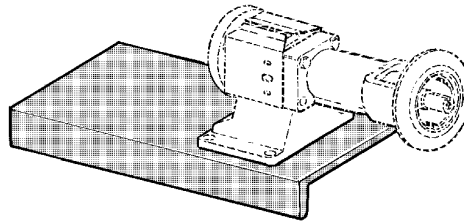

Figure 10 - Channel Base

Motor Frame	Small Bore lb (kg)	Large Bore lb (kg)
48	30 (13.6)	--
56	30 (13.6)	--
143/145T	31 (14.6)	--
182/184T	32 (14.5)	50 (22.6)
213/215T	33 (14.9)	50 (22.6)
254/256T	40 (18.1)	52 (23.5)
284/286T	35 (15.8)	62 (28.1)
284/286TS	--	64 (29.0)
324/326T	--	65 (29.4)
324/326S	--	65 (29.4)
364TS	--	65 (29.4)

Installation

Pump Location

Consider the following when determining a location for the installation of your pump:

- Locate the pump as near as is practical to the liquid supply.
- Keep the supply piping short and straight to keep the pump supplied with liquid and prevent damaging cavitation.
- Make sure the pump is accessible for service and inspection during operation.
- Protect the motor from flooding.

Pump Leveling

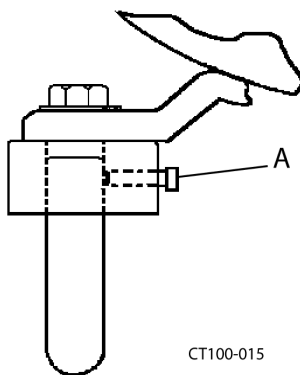

Figure 11 - Setscrew Location

Level the pump by loosening the setscrews on the leg kit (Figure 11, item A) to adjust the length of the legs. Once adjusted, tighten the setscrews.

Supply and Discharge Piping/Valves

⚠ CAUTION

Install the pump and piping system in accordance with local codes and restrictions. Practices described in this manual are recommended for optimum performance.

- Use a line size equal to or larger than the connection size on the pump, especially the inlet supply line.
- Keep the supply line as short and straight as possible and use as few elbows, valves, or other types of restriction as possible. Avoid up and down rises that trap air.
- Maintain a straight length of pipe (Figure 12, item A) at least 8 diameters long at the pump inlet.
- Be certain all joints in the suction line are well-sealed to prevent air leaks.

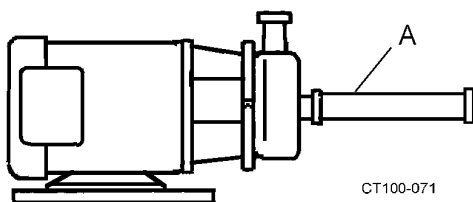

Figure 12 - Straight Pipe Length

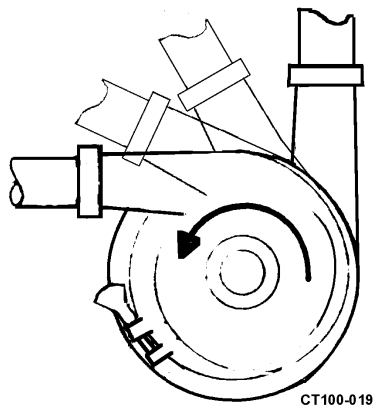

Figure 13 - Recommended Discharge Positions

- The pump casing may be rotated with the discharge connection pointing in any direction. The best pump performance will be with the outlet up, to the left, or positions in between; these positions ensure a flooded casing and prevent problems caused by air in the system (Figure 13).

NOTE: If the casing drain is specified, a full 360° rotation is not available. Orientation must be specified prior to ordering.

- Be certain all joints in the suction line are well-sealed to prevent air leaks.

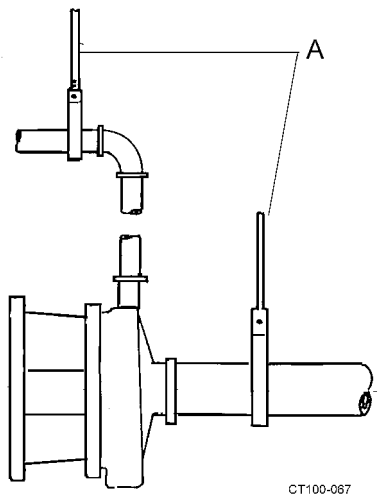

Figure 14 - Pipe Supports

- Support the supply and discharge piping near the pump so that no strain is put on the pump casing.
- If an expansion joint is used, install a pipe support/anchor between the joint and the pump (Figure 14, item A).

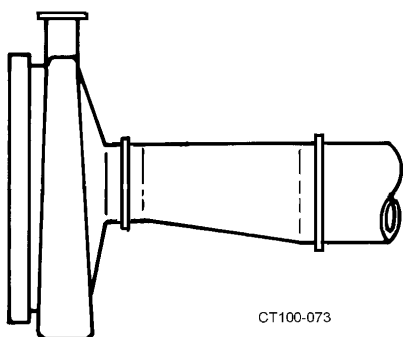

Figure 15 - Correct Eccentric Installation

- If a reducer is connected to an inlet, use an eccentric-type reducer to prevent problems caused by trapped air (Figure 15).
- The supply pipe line slope will depend on application requirements; the best pump operation is with the supply line sloped slightly upward toward the pump to prevent trapping air. If the system must drain into the pump casing, keep the downward slope of the supply line to a minimum, or priming problems may occur.
- Install shutoff valves to isolate the pump from the supply and discharge lines. This will allow the pump to be serviced without draining the system.

⚠ WARNING

The pump and piping may contain sharp edges. Wear gloves while installing and servicing the pump to help avoid injuries from these hazards.

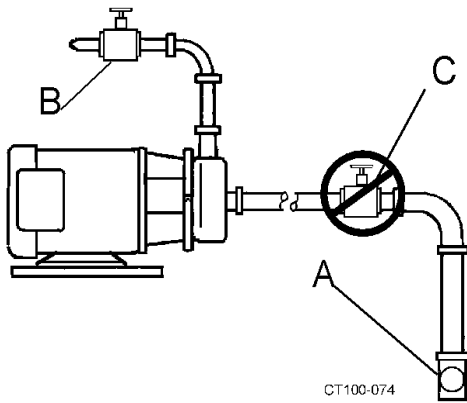

Figure 16 - Valve Piping Installation

Installations That May Cause Operation Problems

- This pump is not self priming. If the pump is installed above the supply liquid level, install a foot valve or other system check valve to keep the system flooded for priming (Figure 16, item A).
- A throttling valve may be required to control the pump flow rate to prevent motor overload. Always install the throttling valve (Figure 16, item B) in the discharge piping, at least 10 pipe diameters from the pump outlet. **Never** install a throttling valve in the supply piping (Figure 16, item C).
- Any system throttling valves or similar devices to control the flow rate must be installed in the discharge line. **Do not** install any system throttling valves or similar devices to control the flow rate in the supply line. Restriction in the supply line may cause cavitation and could cause pump damage.
- “Water hammer” (also known as “slamming”) in the system can damage the pump and other system components. Water hammer often occurs when valves in the system are suddenly closed, causing lines to move violently and with a loud noise. When this condition is present, find and eliminate the source of the water hammer. One way to eliminate water hammer is to slow down the actuation speed of the valve, or use a reverse-acting valve. Actuation closes the valve against the flow.
- Do not expose the pump to freezing temperatures with liquid in the casing. Frozen liquid in the casing will damage the pump. Drain the casing before exposing it to freezing temperatures.

⚠ DANGER

The pump contains internal moving parts. DO NOT put hands or fingers into the pump body ports or drive area at any time during operation. To avoid serious injury, DO NOT install, clean, service, or repair the pump unless all power is off and locked out and the pump is de-pressurized.

⚠ WARNING

To avoid electrical injury and equipment damage, ALL electrical installation should be done by a registered electrician, following industry safety standards.

Electrical Connections



Figure 17 - Motor nameplate

- Read the motor manufacturer's instructions before starting the installation. Follow the manufacturer's lubrication schedules.
- Check the motor nameplate to be sure the motor is compatible with the electrical supply and all wiring, switches, and starters. Make sure all overload protections are correctly sized (take note of the motor data plate).
- Check the pump rotation following the electrical installation. The correct rotation is counterclockwise when facing the pump inlet connection (Figure 13 and Figure 17); clockwise when viewing the fan on the motor.

Flush Seal Option

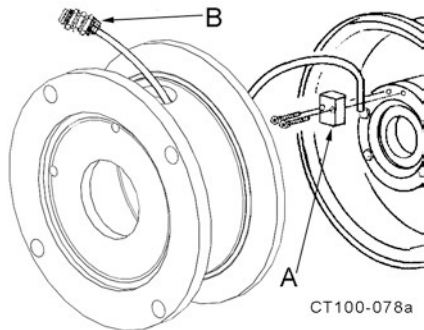

Figure 18 - Cascade System Installation

Type 1 with Cascade

When the Type 1 with Cascade seal type option is ordered, a fitting assembly (Figure 18, item A) is supplied for directing a flow of water onto the backplate/seal area.

- The water cascade block must be above the seal on the assembled backplate to flow water onto the seal face.
- The connection (Figure 18, item B) is 1/4 inch (6.35 mm) O.D. tubing.
- The required flow is approximately 5 U.S. gallons per hour (3.79 liters per hour).
- The recommended water supply is cool and filtered. If the product solidifies at a cool temperature, warm or hot water can be used.

NOTE: To prevent hose contact with the rotating shaft and seal parts during operation, pull the excess hose to the outside of the adapter.

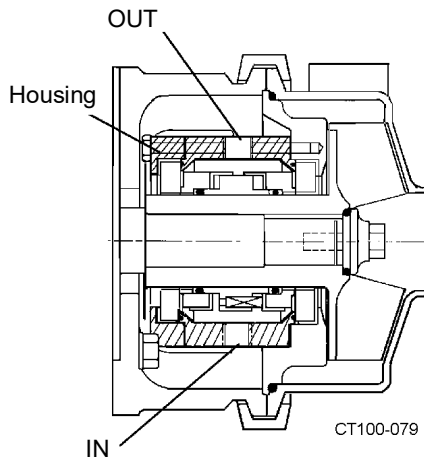

Figure 19 - Type 4 Liquid Flush

Type 4 Seal (Double mechanical with flush)

Attach the seal flush supply to the bottom 1/4-inch NPTF pipe-threaded hole in the flush housing. The drain tubing attached to the top hole allows moderate pressure (30 psi (2 bar) max.) to be supplied to the seals and allows continuous flooding (Figure 19 and Figure 20).

- The required flow is approximately 5 U.S. gallons (18.9 liters) per hour.
- The recommended water supply is cool and filtered. If the product solidifies at a cool temperature, warm or hot water can be used.

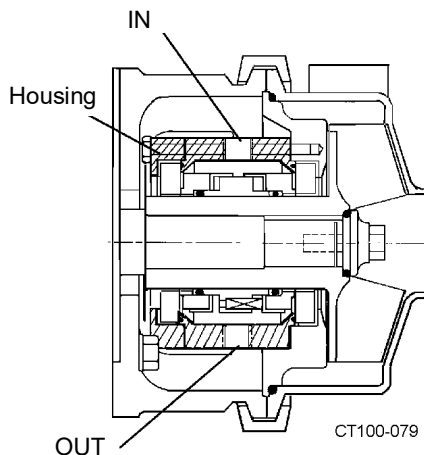

Figure 20 - Type 4 Steam Flush

Before First Startup

Cleaning Safety Procedures

⚠ DANGER

To prevent an accidental start-up, lock out the power source with lock and key.

Clean Pump and Piping

Disassemble the pump and clean all product contact parts and seal parts prior to the first operation. Follow the instructions in the “Cleaning Safety Procedures,” below and “Routine Maintenance” on page 24. Thoroughly clean the pump of any materials which could have accumulated during installation.

Manual Cleaning

Address the following recommendations when manually cleaning your pump:

- Do not use toxic and/or flammable solvents.
- Lock out electrical power and shut off all air prior to cleaning the equipment.
- Keep electrical panel covers closed and power off when washing the equipment.
- Clean up spills as soon as possible.
- Never attempt to clean the equipment while it is operating.
- Wear proper protective clothing.

Cleaning-In-Place (CIP)

When performing CIP:

1. Make certain that all connections in the cleaning circuit are properly applied and tight to avoid contact with hot water or cleaning solutions.
2. When the cleaning cycle is controlled from a remote or automated cleaning center, establish safe procedures to avoid automatic start-up while servicing equipment in the circuit.

NOTE: *Always replace the O-rings when reassembling the pump. If the area behind these seals becomes soiled, contact SPX FLOW Application Engineering for a specific cleaning and sanitizing procedure validated to remove bacteria.*

Preliminary Test Run

If the pump has sat idle for an extended period (greater than 3 months), rotate the shaft by hand before starting the pump. Inspect and replace any elastomers that are brittle or appear damaged. This procedure will ensure that the seals are rotating freely upon one another.

Follow necessary safety precautions.

Test the system using a preliminary run with the materials that will be pumped. **DO NOT** run the pump at this time to produce *final* product.

See “Starting the Pump” on page 22.

⚠ WARNING

The motor must be installed by qualified personnel, e.g., a licensed electrician.

⚠ DANGER

To prevent an accidental start-up, lock out the power source with lock and key.

Check For Possible Motor Overload Conditions

Certain conditions will overload the motor when operating with open unrestricted discharge. This can result in an unacceptably high flow rate. Additional discharge restriction may be required to lower the flow rate and lower the horsepower requirement. **DO NOT** add a restriction to the supply line. If the pump was incorrectly selected, a smaller impeller or a higher motor horsepower may be required.

If you are uncertain about pump selection and application, temporarily install an ammeter in the electrical service (see below).

Ammeter Test

Operate the pump under process conditions and check the motor amp draw versus the nameplate full load rating. If the amp draw exceeds the motor rating, a system change or pump change is required.

If the process conditions and/or liquid changes (higher viscosity, higher specific gravity), recheck the motor amp draw. Contact your authorized SPX FLOW distributor for assistance

Operation

Important Safety Information

⚠ DANGER

The pump contains internal moving parts. DO NOT put hands or fingers into the pump body ports or drive area at any time during operation. To avoid serious injury, DO NOT install, clean, service, or repair the pump unless all power is off and locked out and the pump is de-pressurized.

⚠ WARNING

The pump components and piping may contain sharp edges. Handle the impeller carefully because edges may be sharp. Wear gloves while installing and servicing the pump to help avoid injuries from these hazards.

⚠ CAUTION

These pumps will be severely damaged if operated with closed valves in the discharge or inlet lines. The pump warranty is not valid for damages caused by a hydraulic overload from operation or start-up with a closed valve in the system.

⚠ CAUTION

The motor must be installed by qualified personnel, e.g., a licensed electrician. Motor maintenance, repair and wiring are not covered in this manual. For specific information, contact the motor manufacturer.

Before proceeding, make sure your pump has been correctly installed as described in “Installation,” starting on page 16.

Starting the Pump

1. If the pump has a flush seal option, start the flow of flush water (recommended rate is approximately 5 US gallons per hour (19 liters per hour) before operating the pump.
2. **Before** starting the pump, prime the pump by flooding the pump casing with liquid to avoid damage to pump parts. See “Priming the Pump with the Feed Source Above Pump Level” and “Priming the Pump with the Feed Source Below Pump Level (not recommended)” on page 23.
3. Start the pump motor.
4. Check the pump to see that liquid is flowing and that all piping connections and seals are leak-free.
5. Make sure that the pump is not operating against a closed discharge. Continued operation against a closed discharge will heat the liquid in the casing and lead to pump damage.
6. Slowly adjust the discharge valve until the desired flow is obtained. Observe the pressure gauges and if pressure is not attained quickly, stop the pump and prime it again.

Priming the Pump/ Stopping the Pump

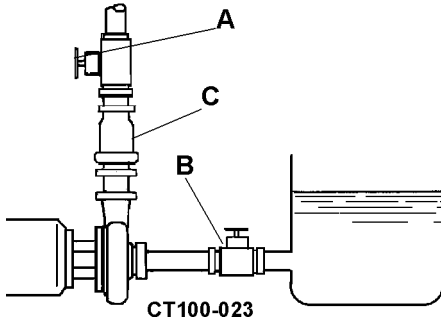

**Figure 21 - Pump Below Supply
(Feed Source Above Pump Level)**

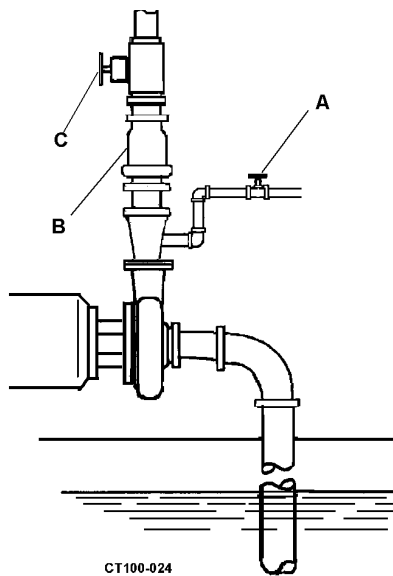

**Figure 22 - Pump Above Supply
(Feed Source Below Pump Level)**

Stopping the Pump

Priming the Pump with the Feed Source Above Pump Level

1. Fill the supply tank with liquid; open the supply line (suction) valve (Figure 21, item B).
2. Vent any air trapped in the supply line or casing by opening the discharge valve (Figure 21, item A).

NOTE: Use a check valve system (Figure 21, item C) to keep the supply line and pump casing flooded with liquid; otherwise the pump must be primed before each operation.

3. Resume the “Starting the Pump” procedure on page 22, step 3.

Priming the Pump with the Feed Source Below Pump Level (not recommended)

The pump will not self-prime if the liquid supply is below the pump level. When the liquid supply is below the pump level, an outside source must be provided for priming. The system NPSHa must be greater than NPSHr in order for the pump to function properly.

1. Open the discharge valve (Figure 22, item C).
2. Open the valve (item A) installed in the outside supply line, until liquid flows from the vent valves.
3. Close the outside supply line.

NOTE: Use a check valve system (Figure 22, item B) to keep the supply line and pump casing flooded with liquid; otherwise the pump must be primed before each operation.

⚠ DANGER

The pump contains internal moving parts. DO NOT put hands or fingers into the pump body ports or drive area at any time during operation. To avoid serious injury, DO NOT install, clean, service, or repair the pump unless all power is off and locked out and the pump is de-pressurized.

1. To stop the pump, shut off power to the pump motor.

NOTE: Liquid in the system can flow freely through the pump; the pump does not act as a shutoff valve.

2. Shut off supply and discharge lines.

Maintenance

Important Safety Information

⚠ DANGER

The pump contains internal moving parts. DO NOT put hands or fingers into the pump body ports or drive area at any time during operation. To avoid serious injury, DO NOT install, clean, service, or repair the pump unless all power is off and locked out and the pump is de-pressurized.

⚠ WARNING

The pump components and piping may contain sharp edges. Handle the impeller carefully because edges may be sharp. Wear gloves while installing and servicing the pump to help avoid injuries from these hazards.

⚠ CAUTION

Make sure to keep the work area clear of machine parts, tools, product lines, foreign materials, and power cables to avoid potential hazards.

⚠ CAUTION

Make sure appropriate lighting is available: at least 1000 lux, independent of daylight and weather conditions.

⚠ CAUTION

Before carrying out any maintenance and repair work on cold components, ensure that the machine parts in question are sufficiently heated. The contact temperature of accessible machine parts must not be lower than those in the EN ISO 13732-1.

Before detaching port connections to the pump:

- Close the suction and discharge valves.
- Drain the pump and clean or rinse, if necessary.
- Disconnect or shut off the electrical supply and lock out all power.

Scheduled Maintenance

A routine maintenance program can extend the life of your pump. Make sure to keep maintenance records. These records will help pinpoint potential problems and causes.

Routine Maintenance

Your scheduled routine maintenance should include the following items:

- Check for unusual noise, vibration, and bearing temperatures
- Inspect the pump and piping for leaks
- Check the Mechanical Seal area for leakage (No leakage is desired)
- Check the backplate gasket for wear/damage
- Bearing lubrication (See motor manufacturer for correct specifications)
- Seal Monitoring
- Vibration analysis
- Check the discharge pressure
- Temperature monitoring

Disassembly of Pump with a Type 1 Seal

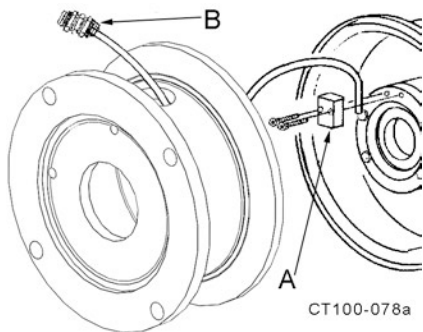

Figure 23 - Removal of the Water Cascade System (if supplied)

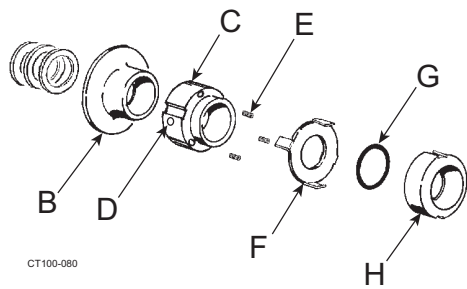

Figure 24 - Type 1 Seal Items



Figure 25 - Moving Rotary Seal Up the Shaft

1. Shut off the product flow to the pump and relieve any product pressure.
 2. Shut off and lock out power to the pump.
 3. Disconnect the suction and discharge pipe fittings.
 4. Remove the casing clamp and casing.
 5. Slide the O-ring off of the backplate.
 6. Remove the impeller retainer bolt and shaft O-ring.
- NOTE:** The retainer bolt has standard right-hand threads.
7. Pull off the impeller/backplate assembly and place it on a clean flat surface with the impeller shaft facing up.

⚠ CAUTION

Handle the impeller/backplate assembly with care to prevent damage to the seal components.

NOTE: If the assembly cannot be removed from the motor shaft by hand, contact Customer Service.

8. If supplied, loosen the socket head screws holding the water cascade block on the stationary seat retainer, then remove the plastic hose.
9. Locate the shims on the motor shaft and remove them.

NOTE: The motor shaft shims may fall off the motor shaft or hang up inside the deflector. **Be sure to place all shims back on the motor shaft.**

10. Remove the deflector (Figure 24, item B).
11. Loosen the two (2) setscrews (Figure 24, item D) in the spring retainer (item C) and slide the retainer and washer (item F) off the shaft. Save the three (3) springs (item E).
12. Use the backplate to slide the rotary seal up the impeller shaft approximately 1-1/2 inches (Figure 25).



CT100-082

Figure 26 - Push Rotary Seal Down

13. With the backplate resting on the impeller, push the rotary seal toward the backplate until the O-ring is free (Figure 26).
14. Remove the O-ring, then lift the rotary seal off the shaft (Figure 24, items G and H).
15. Lift the backplate off the impeller.

CAUTION

To avoid seal failure, DO NOT place fingers on the carbon seal face.

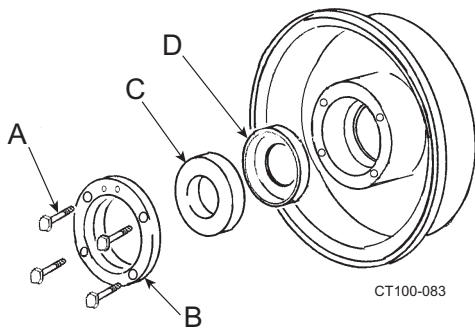

CT100-083

Figure 27 - Removing Stationary Seal

16. Remove the four 1/4" hex bolts and stationary seat retainer ring (Figure 27, items A and B).
17. Pull the stationary seal and L-gasket out of the backplate (Figure 27, items C and D).

NOTE: The stationary seal is brittle. Prying or hammering on the seal plate can shatter the seal. If the stationary seal cannot be removed by hand, place a 2-1/4 inch diameter plastic or wood rod on the impeller side of the seal and apply even pressure to dislodge the seal.

Inspect Parts

Once disassembly is complete, perform the following inspections:

- Examine all seal surfaces and replace seals that are scratched, cracked and/or braised.
- Inspect all O-rings and O-ring seats for abrasions, cuts or other wear that could cause leakage.
- Clean all seat areas and alignment surfaces.

NOTE: Stationary seals are reversible. Use both sides before replacing them.

NOTE: Replace the rotary seal when the seal face extends less than 1/32 inch (1 mm) from the body (Figure 28).

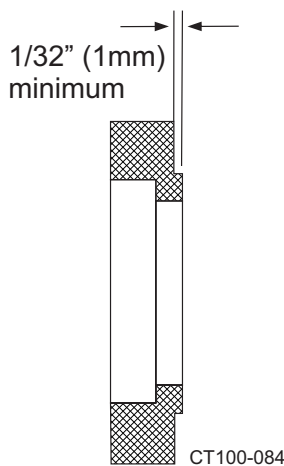

CT100-084

Figure 28 - Rotary Seal Replacement Minimum

Assembly of Pump with a Type 1 Seal

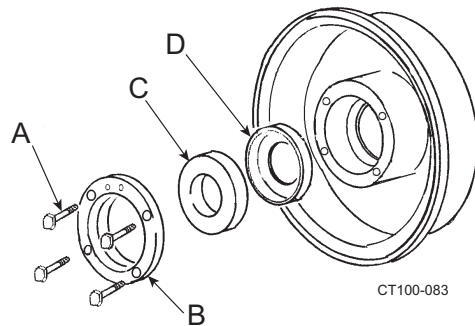

Figure 29 - Stationary Seal Assembly

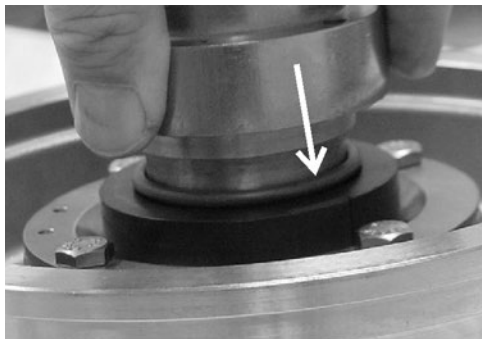

Figure 30 - Installing O-ring

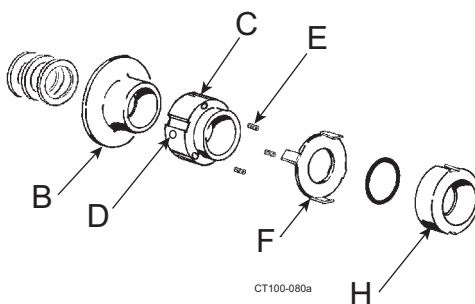

Figure 31 - Type 1 Seal Assembly

Backplate Assembly

1. Lightly lubricate both sides of the L-gasket (Figure 29, item D) with a sanitary lubricant and insert it into the backplate seal cavity.
2. Place the stationary seal into the L-gasket (Figure 29, items C and D).
3. Place the seat retainer over the stationary seal and secure the retainer with four 1/4-20 x 1/2 inch hex head cap screws (Figure 29, items B and A).
4. Tighten the cap screws evenly.

Backplate/Impeller Assembly

1. Place the impeller on a clean flat surface, shaft-end up, and slide the assembled backplate onto the impeller shaft.

NOTE: Avoid hitting the stationary seal against the impeller shaft, as it could break the seal.

2. Carefully place the rotary seal in position over the impeller shaft and down against the stationary seal.
3. Lubricate and slide the seal O-ring onto the impeller shaft. Use the spring retainer as a tool to push the O-ring into the rotary seal (Figure 30).
4. Slide the tabbed washer (Figure 31, item F) over the impeller shaft and engage the tabs of the washer into notches on the outside of the rotary seal (Figure 31, items F and H).
5. Install the three seal springs into the holes in the spring retainer (Figure 31, items C and E). Hold the springs in place with RTV silicone sealant.
6. Slide the spring retainer over the impeller shaft until the slots in the spring retainer engage the drive tabs on the washer and the springs rest against the washer (Figure 31).
7. With the backplate against the impeller, push the spring retainer down to compress the springs until the length of visible spring is approximately 1/8".
8. Lock the spring retainer in place by tightening the setscrews (Figure 31, item D).
9. Install the deflector onto the impeller shaft (Figure 31, item B).

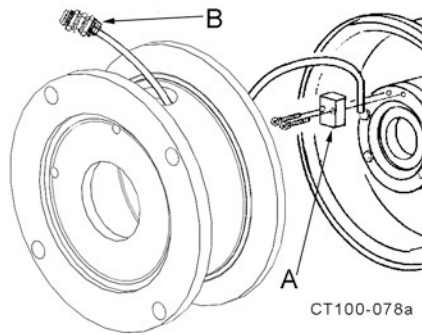

Figure 32 - Installing Water Cascade System

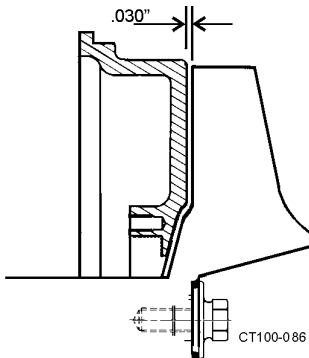

Figure 33 - Clearance Between Impeller and Backplate

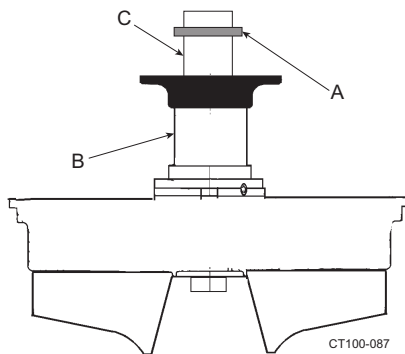

Figure 34 - Locations of Shims

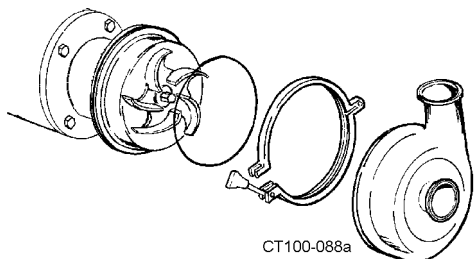

Figure 35 - Install Casing

10. If your system has a water cascade, thread the water cascade hose through the adapter and install the cascade block on the backplate (Figure 32, items A and B).
11. Slide the motor shims onto the shaft. Use the same number of shims that were removed when the pump was disassembled.
12. Install the impeller assembly on the stub shaft of the motor.
13. Hand-tighten the impeller retainer bolt on the shaft.

14. Check the space between the back of the impeller and the backplate with a feeler gauge (0.030" nominal) while holding the backplate tight against the bearing housing flange. (Any axial movement of the shaft should not be added to the 0.030" nominal clearance) (Figure 33). If needed, change this clearance by adding or removing shims. Shims (Figure 34, item A) are added on the drive shaft (Figure 34, item C) behind the impeller shaft (Figure 34, item B).

15. Confirm the operating clearances by clamping the casing to the bearing housing flange and rotating the shaft/impeller manually to be sure the impeller does not touch the casing or backplate.

16. When the proper shim pack is confirmed, remove the casing, impeller, and backplate, leaving the shim pack on the shaft.

17. Remove the backplate/impeller assembly and apply anti-seize or equal compound to the motor shaft and install the key.

NOTE: Always replace the O-rings and L-gasket when reassembling the pump. If the area behind these seals becomes soiled, contact SPX FLOW Application Engineering for a specific cleaning and sanitizing procedure validated to remove bacteria.

18. Install the casing O-ring on the backplate and clamp the casing in place (Figure 35).

NOTE: Rotate the impeller manually to ensure it does not rub on the backplate or casing.

Disassembly of Pump with a Type 4 Double Seal

The Type 4 Seal is essentially two Type 1 seals assembled back to back in a chamber which bolts to the backplate in place of the stationary seat retainer. Except for the additional components (chamber, seals), Type 1 and Type 4 components are interchangeable (Figure 36).

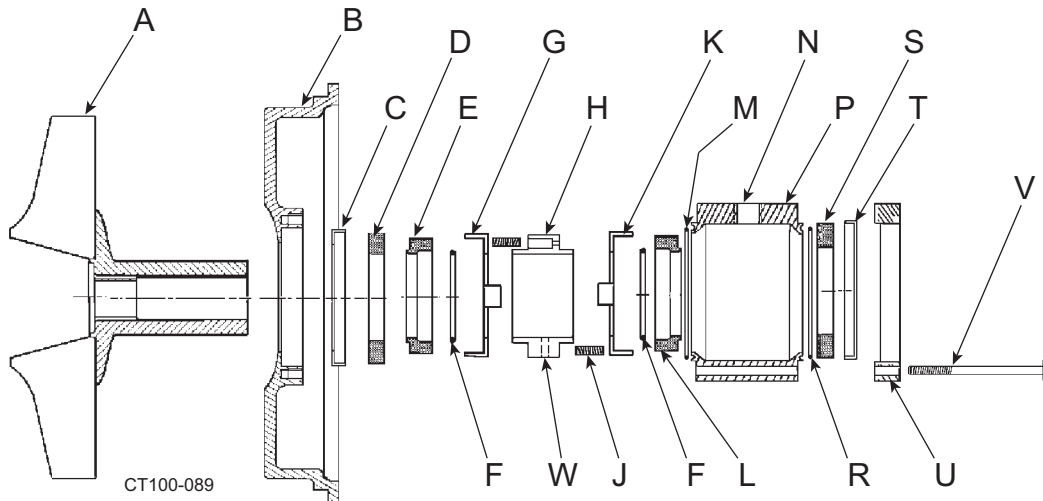

Figure 36 - Type 4 Seal Components

A. Impeller	F. O-ring	L. Rotary Seal	S. Stationary Seal
B. Backplate	G. Washer	M. O-ring	T. L-gasket
C. L-gasket	H. Spring Retainer	N. NPT Port	U. Seat Retainer
D. Stationary Seal	J. Spring	P. Flush Housing	V. Hex Head Screw (4)
E. Rotary Seal	K. Washer	R. O-ring	W. Setscrew

⚠ CAUTION

Handle the impeller/backplate assembly with care to prevent damage to the seal components.

1. Shut off the product flow to the pump and relieve any product pressure.
2. Shut off and lock out power to the pump.
3. Disconnect the suction and discharge pipe fittings.
4. Remove flush piping from the flush housing.
5. Remove the casing clamp and casing. Slide the O-ring off the backplate.
6. Remove the impeller retainer bolt and shaft O-ring.

NOTE: The retainer bolt has standard right-hand threads.

7. Pull off the impeller/backplate assembly and place it on a clean flat surface with the impeller shaft facing up.

NOTE: If the assembly cannot be removed from the motor shaft by hand, contact Customer Service.

8. Locate the shims on the motor shaft and remove them.

NOTE: Motor shaft shims may fall off the motor shaft or hang up inside the deflector. **Be sure to place all shims back on the motor shaft.**

⚠ CAUTION

Handle the impeller/backplate assembly with care to prevent damage to the seal components.

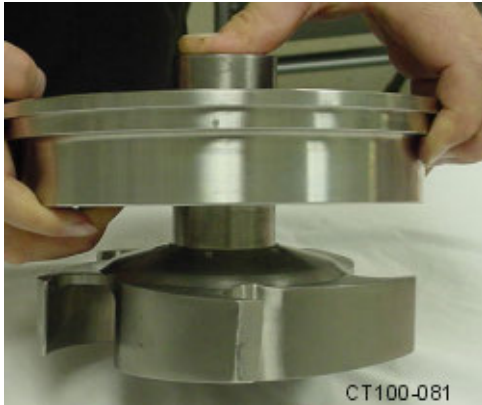

Figure 37 - Move Rotary Seal Up Shaft

9. Place the impeller assembly **face down** (on impeller vanes) and remove the hex head screws (Figure 36, item V) from the back of the seal assembly.
 10. Carefully lift off the seat retainer, O-ring, L-gasket, stationary seal, and flush housing (Figure 36, items P, R, T, S and U).
 11. Loosen (2) setscrews in the spring retainer (Figure 36, items W and H).
 12. Lift off rotating seal components. See Figure 38 on page 31:
 - Rotary Seal (item L)
 - O-ring (item M)
 - Washer (item K)
 - Spring Retainer (item H)
 - Springs (there are six springs, 3 up and 3 down) (item J)
 - Washer (item G)
 13. Use the backplate to slide the rotary seal up the impeller shaft approximately 1-1/2 inches (Figure 37).
 14. With the backplate resting on the impeller, push the rotary seal toward the backplate until the O-ring is free.
 15. See Figure 38 on page 31. Remove the stationary seal (item D) and L-gasket (item C) from the backplate.
- NOTE:** The stationary seal is brittle. Prying or hammering on the seal plate can shatter the seal. If the stationary seal cannot be removed by hand, place a 2-1/4 inch diameter plastic or wood rod on the impeller side of the seal and apply even pressure to dislodge the seal.
16. Inspect and replace all damaged and worn parts.

Assembly of Pump with Type 4 Seal

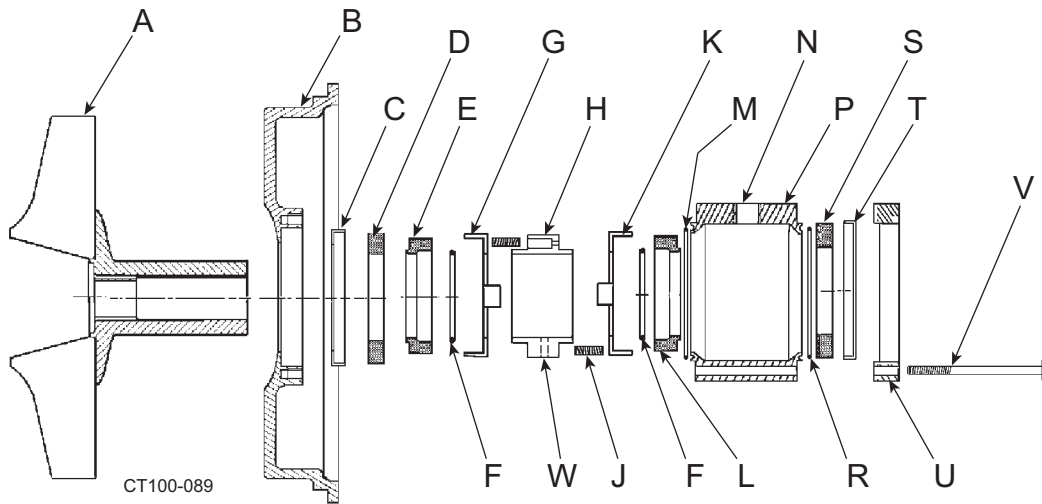

Figure 38 - Type 4 Seal Components

A. Impeller	F. O-ring	L. Rotary Seal	S. Stationary Seal
B. Backplate	G. Washer	M. O-ring	T. L-gasket
C. L-gasket	H. Spring Retainer	N. NPT Port	U. Seat Retainer
D. Stationary Seal	J. Spring	P. Flush Housing	V. Hex Head Screw (4)
E. Rotary Seal	K. Washer	R. O-ring	W. Setscrew

CAUTION

Handle the impeller/backplate assembly with care to prevent damage to the seal components.

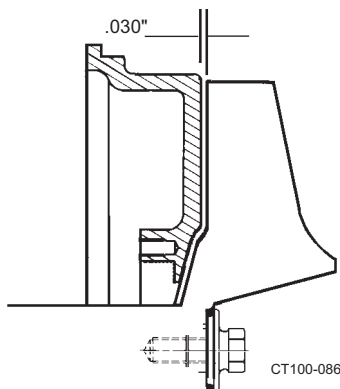

Figure 39 - Shim Placement

1. Clean all parts and lubricate all elastomer (rubber-like) parts.
2. Install the L-gasket in the backplate (Figure 38, items B and C).
3. Install the L-gasket in the seat retainer (Figure 38, item T).
4. Install the stationary seals (Figure 38, item S) in the L-gaskets.
5. Place the backplate and rotary seal onto the impeller shaft.
6. Temporarily put 0.03" shims between the impeller vane and back plate to a preset clearance. **Be sure to remove the shims before final assembly** (Figure 39).
7. Place the O-ring (Figure 38, item F) on the shaft and use the spring retainer to push the O-ring into the rotary seal (Figure 40).
8. Place the washer (Figure 38, item G) over the rotary seal with tabs in the outside diameter notches.
9. Place three springs (Figure 38, item J) in one side of the spring retainer (item H). Hold them in place with silicone sealer, and slide the spring retainer (with the springs down) onto the impeller shaft the against the washer.

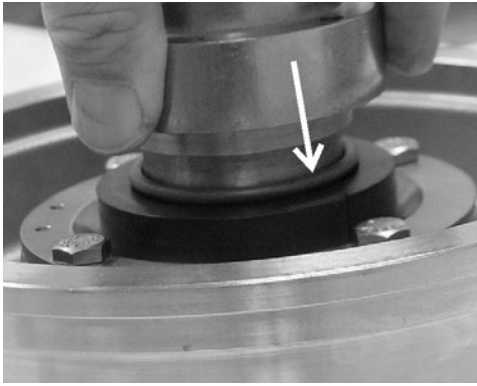

Figure 40 - Installing O-ring Using Spring Retainer

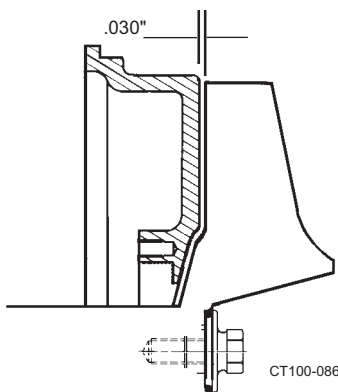

Figure 41 - Clearance Between Impeller and Backplate

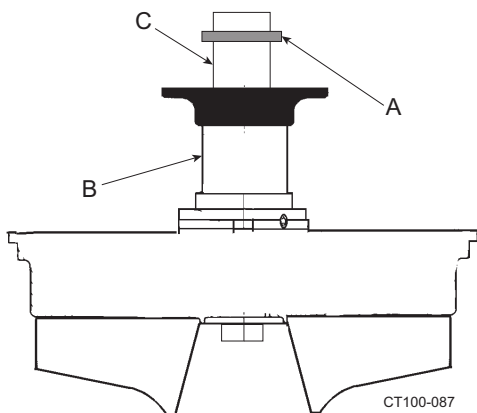

Figure 42 - Locations of Shims

10. Place the remaining three (3) springs in the spring retainer.
11. Slide the washer and O-ring (Figure 38, items K and F) onto the shaft against the spring retainer.
12. Use the spring retainer to press the O-ring into the rotary seal.
13. Remove the 1/4 NPT plug from the center port on the flush housing (Figure 38, item N).
14. Install an O-ring (Figure 38, items M and R) in both ends of the housing.
15. Install the L-gasket in the seat retainer (Figure 38, items T and U).
16. Install the stationary seal (Figure 38, item S) in the L-gasket.
17. Install the housing over the seal assembly.
18. With flush ports facing away from the backplate, place the seat retainer (Figure 38, item U) on the housing.
19. Tighten the seat retainer in place with four (4) hex screws (Figure 38, item V).

NOTE: Be sure to tighten the screws evenly until full metal-to-metal contact is made on the backplate and seat retainer.

20. Install the original shims on the motor adapter shaft.
21. Install the backplate with the seal assembly and impeller on the motor shaft.
22. Check the impeller/backplate clearance with the backplate held firmly in position against the motor adapter. Check the space between the back of the impeller and the backplate with a feeler gauge (0.030" nominal) while holding the backplate tight against the bearing housing flange. Any axial movement of the shaft should not be added to the 0.030" nominal clearance (Figure 41). If needed, change this clearance by adding or removing shims. Shims (Figure 42, item A) are added on the drive shaft (Figure 42, item C) behind the impeller shaft (Figure 42, item B).
23. Confirm the operating clearances by clamping the casing to the bearing housing flange and rotating the shaft/impeller manually to be sure the impeller does not touch the casing or backplate.
24. Tighten the setscrews in the spring retainer through the 1/4" NPT center port in the flush housing (Figure 38, item N).
25. Insert the plug in the port in the flush housing (item N) and tighten it.
26. Remove the backplate/impeller assembly and apply anti-seize or equal compound to the motor shaft and install the key.
27. Install the backplate/impeller assembly and lock it in place using the O-ring and impeller retainer bolt.
28. Rotate the flush housing until a flush port is accessible from the top of the motor adapter.

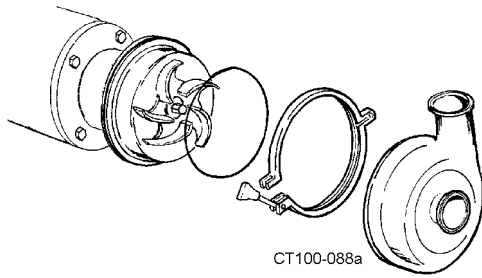

Figure 43 - Install Casing

NOTE: Always replace the O-rings and L-gasket when reassembling the pump. If the area behind these seals becomes soiled, contact SPX FLOW Application Engineering for a specific cleaning and sanitizing procedure validated to remove bacteria.

29. Install the casing O-ring on the backplate and clamp the casing in place (Figure 43).

NOTE: Rotate the impeller manually to ensure it does not rub on the backplate or casing.

30. Install the flush piping.

Disassembly of Modular Base-Mounted Pumps

Refer to “Disassembly of Pump with a Type 1 Seal” on page 25 and “Disassembly of Pump with a Type 4 Double Seal” on page 29 for information on disassembling the pump seal items.

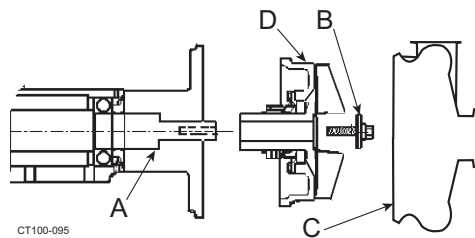

Figure 44 - Removing the Impeller Assembly

1. Shut off the product flow to the pump and relieve any product pressure.

2. Shut off and lock out power to the pump.

3. Disconnect the suction and discharge pipe fittings.

4. Remove the casing clamp and casing (Figure 44, item C). Slide the O-ring off of the backplate

5. Remove the impeller retainer bolt and shaft O-ring (Figure 44, item B).

6. Pull the impeller/backplate assembly off the bearing housing shaft (Figure 44, items D and A).

7. Remove the coupling cover cap screws (Figure 45, item B).

8. Loosen the setscrews on the pump coupling (Figure 45, item A).

9. Remove the stand/housing assembly, then remove the end cap (Figure 49, item C on page 34).

10. Push the shaft and bearing assembly out of the housing from the impeller end. (Figure 46).

11. Remove the retaining ring and press the bearings off the shaft (Figure 46, items A and B).

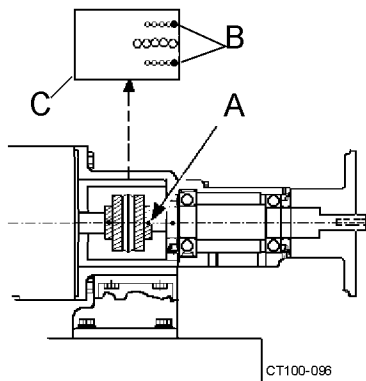

Figure 45 - Removing Coupling Covers

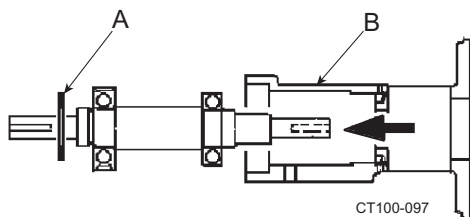

Figure 46 - Bearing Shaft Assembly Removal

Disassembling the Outer Seal Assemblies

1. Using an 1/8" hex wrench, loosen the setscrews (Figure 47, item A).

NOTE: The setscrews are located opposite the grease fittings in the adapter or end cap.

2. Remove the impeller end of the bearing housing (Figure 47, item B).
3. Remove the outer seal ring assemblies (the inner seal ring and O-rings). See Figure 47 and Figure 48.

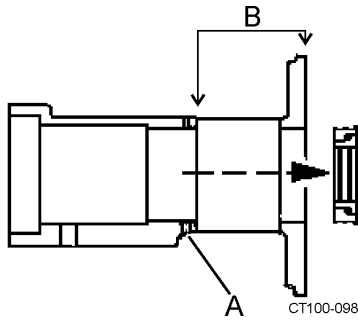

Figure 47 - Remove Setscrews

Assembling the Outer Seal Assemblies

Reverse the disassembly procedure (above) with the added step of installing new O-rings in the seal rings.

NOTE: Figure 47 shows the seal position at the motor end. Seals at the pump end face inward. Make sure to tighten the setscrews when installing the outer seal assemblies (Figure 49).

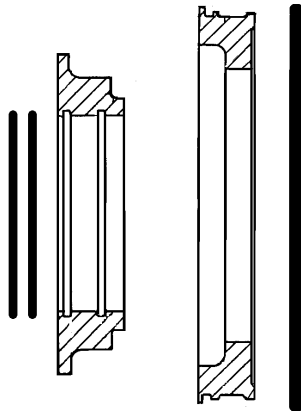

Figure 48 - Seal Configuration

NOTE: Replace all rubber parts whenever a unit is dismantled for inspection or repair. Lubricate the rubber parts with an approved/sanitary lubricant prior to assembly.

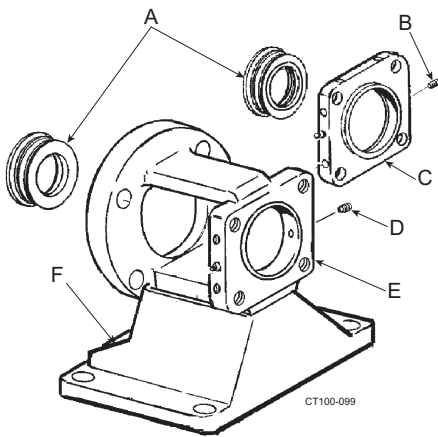

Figure 49 - Outer Seal Assemblies

- | | |
|------------------------|-------------|
| A. Outer Seal Assembly | D. Setscrew |
| B. Setscrew | E. Adapter |
| C. End Cap | F. Stand |

Pre-assembled (Cartridge) Seals

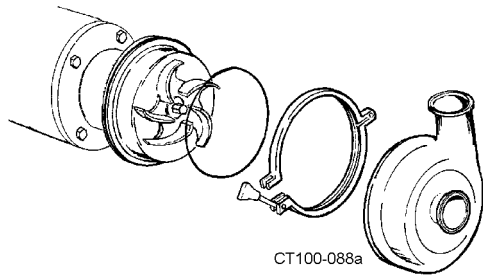

Figure 50 - Remove Casing Clamp, Casing and O-ring

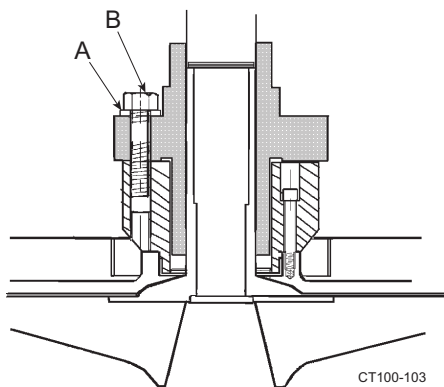

Figure 51 - Removal of Wet End

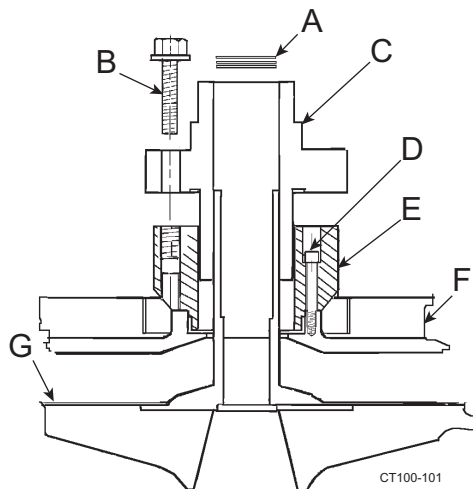

Figure 52 - Remove Seal Assembly.

- | | |
|----------------------|--------------|
| A. Shims | E. Adapter |
| B. Cap Screw | F. Backplate |
| C. Cartridge Seal | G. Impeller |
| D. Socket Head Screw | |

Pre-assembled (Cartridge) seals have all of the seal components mounted to a flange, and are pre-adjusted at the factory. Follow the seal manufacturer's (John Crane, A.W. Chesterton, etc.) recommendations regarding application, operation and maintenance.

NOTE: The cartridge seal comes with a set of removable lugs/spacers in place that are used to hold the assembly together until installation is final. Do not remove these lugs until installation is complete and you are instructed to do so in step 17 on page 38.

Disassembly of a Pump with Pre-assembled (Cartridge) Seals

1. Remove all flush connections and fittings.
2. Remove the casing clamp, casing, and O-ring from the housing flange (Figure 50).
3. Remove the impeller retainer bolt and O-ring; then loosen the seal setscrews (Figure 51, item A).
4. Pull the impeller, backplate, and seal off the bearing shaft as a unit. Set the assembly face down (on the impeller).

NOTE: The clearance shims that position the impeller within the casing are at the end of the impeller hub (inside the seal.) Keep the shims together as a set for reassembly (Figure 52).

5. Remove the cap screws (Figure 52, item B) holding the cartridge seal to the seal adapter (Figure 52, items C and E).
6. Remove the seal unit from the backplate assembly.
7. Pull the seal from the seal adapter. (Figure 52, items C and E)
8. Remove the seal adapter by removing the socket head cap screws (Figure 52, item D) holding the adapter to the backplate.

Assembly of a Pump with Pre-assembled (Cartridge) seals

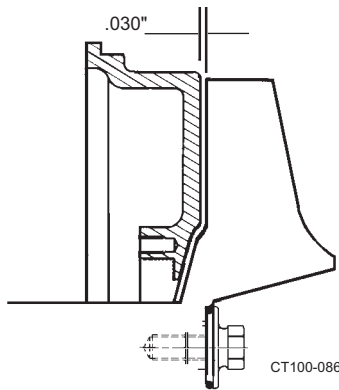

Figure 53 - Clearance Between Impeller and Backplate

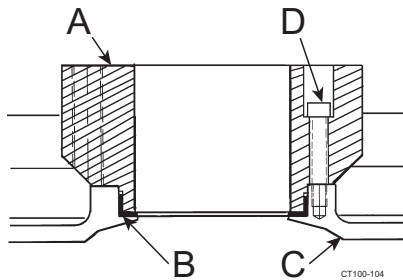

Figure 54 - Insert L-gasket, Fasten Adapter in Place

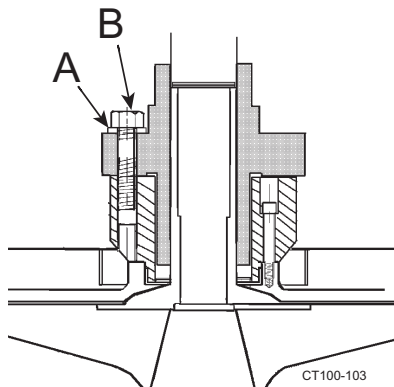

Figure 55 - Fastening Seal Unit in Place

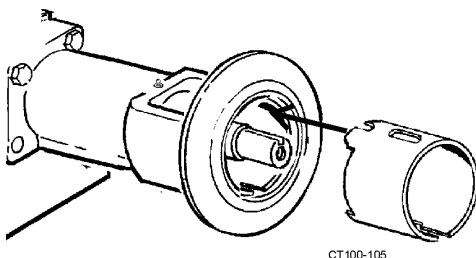

Figure 56 - Installing the Guard

1. Place the shims, backplate and impeller on the shaft assembly. Hand-tighten the impeller retainer bolt on the shaft.
2. Check the impeller/backplate clearance with the backplate held firmly in position against the motor adapter. Check the space between the back of the impeller and the backplate with a feeler gauge (0.030" nominal) while holding the backplate tight against the bearing housing flange. Any axial movement of the shaft should not be added to the 0.030" nominal clearance (Figure 53). If needed, change this clearance by adding or removing shims. Shims (Figure 52, item A) are added on the drive shaft behind the impeller shaft (Figure 52, item G).
3. Confirm the operating clearances by clamping the casing to the bearing housing flange and rotating the shaft/impeller manually to be sure the impeller does not touch the casing or backplate.
4. When the proper shim pack is confirmed, remove the casing, impeller and backplate, leaving the shim pack on the shaft.
5. Insert the L-gasket into the backplate (Figure 54, items B and C).
6. Insert the cartridge adapter (Figure 54, item A) into the backplate (Figure 54, item C) and tighten with four socket head cap screws (Figure 54, item D).
7. Install the cartridge seal unit and use the retaining bolts (Figure 55, item B) and flat washers (Figure 55, item A) to secure the unit to the cartridge adapter. Do not tighten the retaining bolts yet.

CAUTION

Be sure the removable lugs/spacers that position the rotating part of the seal in the housing are in place at this time.

8. Apply FDA-approved anti-seize compound to the shaft.

9. (Pedestal Pump only) Install and position the seal guard (Figure 56).

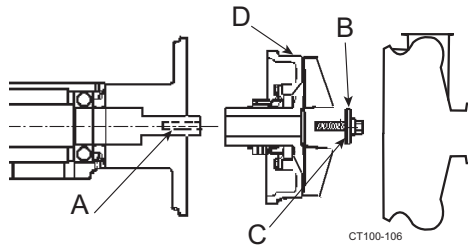

Figure 57 - Installing Impeller Assembly

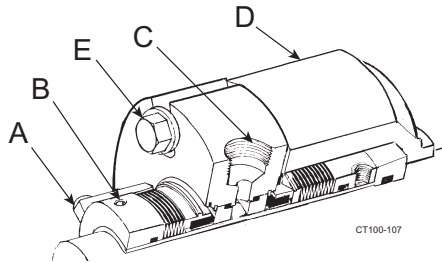

Figure 58 - Typical Cartridge Seal

- | | |
|-----------------|-----------------|
| A. Lugs/Spacers | D. Seal Adapter |
| B. Setscrew (2) | E. Cap Screws |
| C. Flush Pots | |

10. Slide the impeller, backplate and seal unit onto the shaft.

NOTE: Be sure the flushing ports in the cartridge seal are positioned with the inlet toward the bottom and the outlet toward the top (Figure 58, item C).

11. Install the impeller key (Figure 57, item A).

12. Install the O-ring on the impeller retainer bolt (Figure 57, item C).

13. Install the impeller retainer bolt and tighten it (Figure 57, item B).

14. Hold the backplate in place and tighten the cartridge seal into the cartridge adapter by tightening the cap screws (Figure 58, item E).

NOTE: The backplate and seal can be rotated to give access to the bolts through the holes in the guard.

15. Install the O-ring and casing; clamp in place (Figure 59).

16. Tighten the two setscrews to the shaft (Figure 58, item B).

17. Remove the lugs/spacers (Figure 58, item A).

NOTE: Keep the lugs/spacers to reinstall on the seal cartridge if removal is ever required.

18. Connect the flushing fluid and flood seal.

19. Turn the shaft manually to be sure the shaft rotates without the impeller hitting or binding.

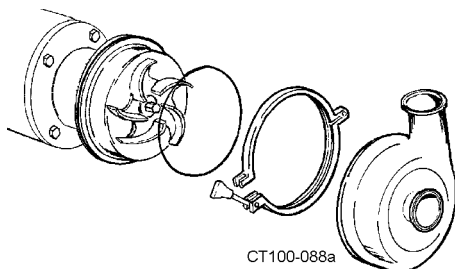

Figure 59 - Install O-ring, Casing, Clamp

Pedestal Base-Mounted Pump Housing Lubrication

Waukesha Cherry-Burrell brand Series 200 Pedestal Pumps are lubricated with NLGI grade 2 Lithium Complex Grease. Use only NLGI grade 2 Lithium Complex thickened greases to replenish the bearing grease supply. The location of the grease fittings is indicated in Figure 60.

NOTE: Combining greases that will not mix with the products above can change the viscosity/consistency of the grease, resulting in bearing damage. If there is doubt, remove the bearings, clean, and re-pack them.

For compatible lubricants, contact SPX FLOW Application Engineering at 1-800-252-5200 or 262-728-1900.

Lubrication Schedule

Size/RPM	Hours
Small Bore/1750 RPM	4400
Small Bore/3500 RPM	2000
Large Bore/1750 RPM	2000
Large Bore/3500 RPM	1000

NOTE: If operating temperatures are over 158°F (70°C), reduce hours by half for every 27°F (15°C) over the operating temperature.

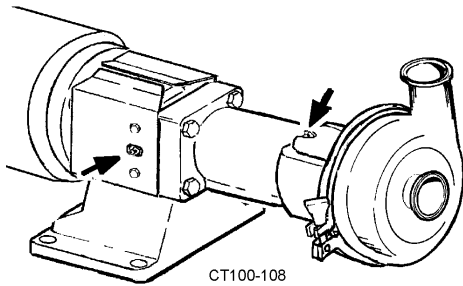

Figure 60 - Grease Fittings on the Pedestal Pump

Pump Alignment

A flexible coupling is used to compensate for end play and small differences in alignment. The pump and drive shaft should be aligned as closely as possible.

Checking Angular Alignment

Using feeler gauges or taper gauges, adjust to get equal dimension at all points. At the same time, set space between the coupling halves to the manufacturer's recommended distance.

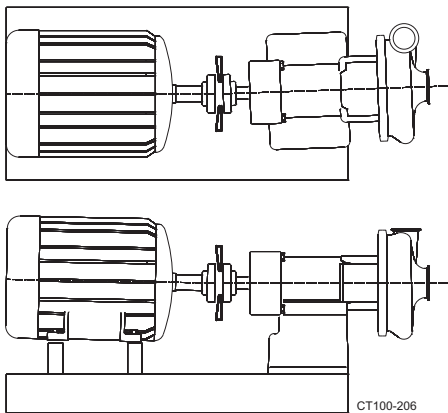

Figure 61 - Checking Angular Alignment

Checking Parallel Alignment

Using straight edges and shims, move the drive and shim height as needed.

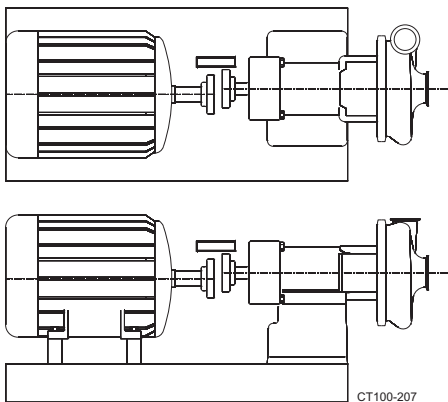

Figure 62 - Checking Parallel Alignment

Servicing the Electric Motor

CAUTION

Do not over-grease. Excessive lubrication may damage the unit.

DANGER

Disconnect all power sources to the unit and discharge all parts which may retain an electrical charge before attempting any maintenance or repair. Screens and covers must be maintained in place when the unit is in operation.

Replacing the Impeller stud and nut

Size	Dim. "A"
2045	0.375"
2065-2105 Small Bore	0.375"
2065-2105 Large Bore	0.437

See the motor manufacturer's instructions for specific service information.

General Service Information

Inspect units at regular intervals. Keep units clean and ventilation openings clear of dust, dirt or other debris.

Lubricate the units per the manufacturer's instructions and the instruction plate on the unit.

Motor Lubrication Instructions

Some small motors have sealed-for-life bearings which require no lubrication.

Greasable bearings are shipped with a high-quality, wide-temperature-range grease in the bearings.

Some motors can be greased. Refer to the motor manufacturer's instructions for more information regarding lubrication procedures and additional service procedures.

As of 11/1/04, there was a design change and the one-piece impeller retainer bolt was replaced by a stud and nut assembly. See Figure 63.

1. Remove the impeller retainer nut (or for older pumps, the impeller retainer bolt).
2. Pumps newer than 11/1/04: Remove the stud.
3. Insert the new stud, making sure to position it according to the dimension "A" shown. Secure it with Loctite®.
4. Screw on the impeller retainer nut.

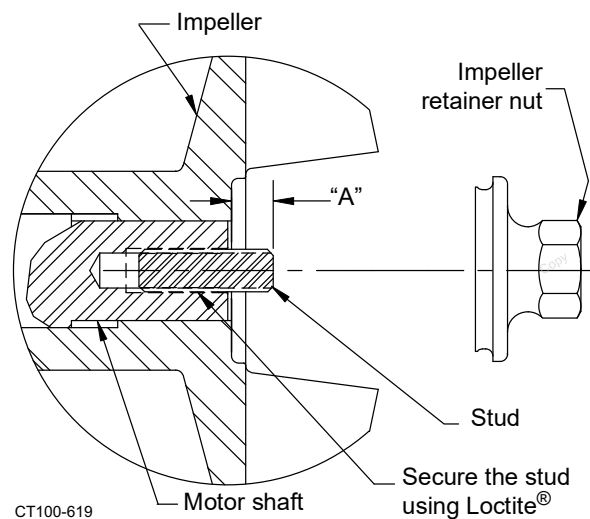
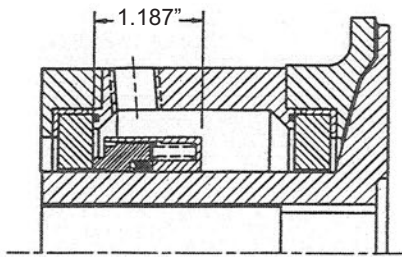

Figure 63 - Replacing the Impeller stud and nut

Standard Seal Dimensions

The following seal assemblies are available with the 200 Series Pumps. These sketches provide the installed length dimension for each seal to facilitate assembly.



John Crane Type 8-1
Inside Mounted Seal

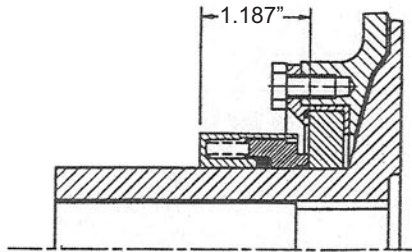

John Crane Type 8B2
Outside Mounted Seal

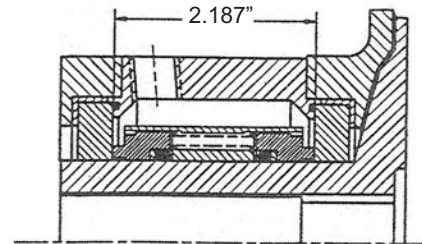

John Crane Type 8-1 Double Seal
(Length is set by seal chamber)

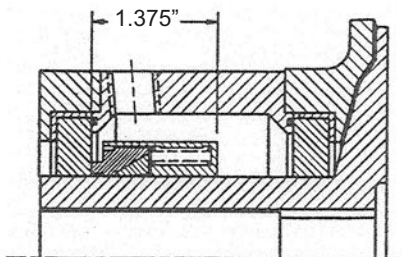

John Crane Type 9
Inside Mounted Seal

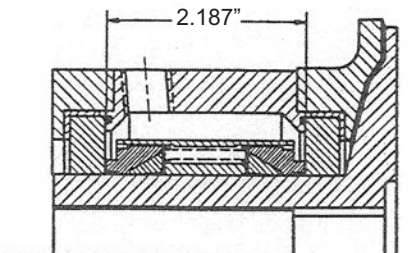

John Crane Type 9 Double Seal
(Length is set by seal chamber)

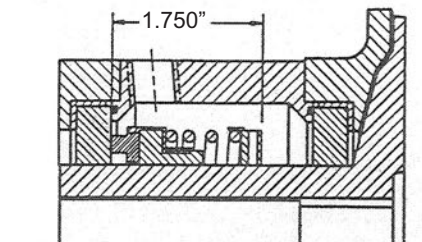

John Crane Type 21
Inside Mounted Seal

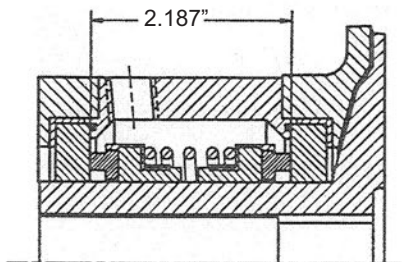

John Crane Type 21 Double Seal
(Length is set by seal chamber)

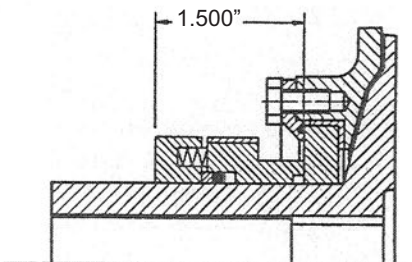

Chesterton 440
Outside Mounted Seal

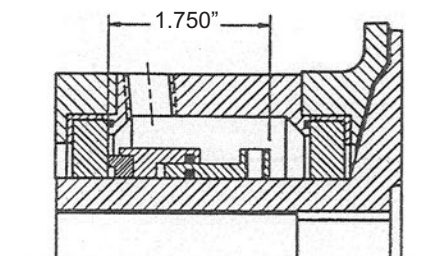

Chesterton 880
Inside Mounted Seal

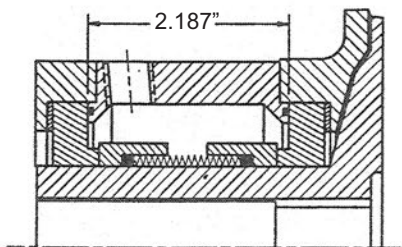

Durametallic Type "CRO"
Double Seal

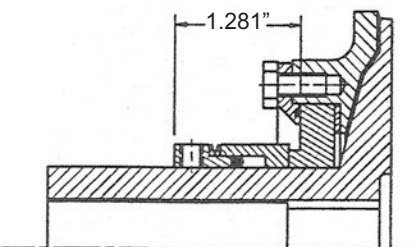

Durametallic Type "RA"
Externally Mounted

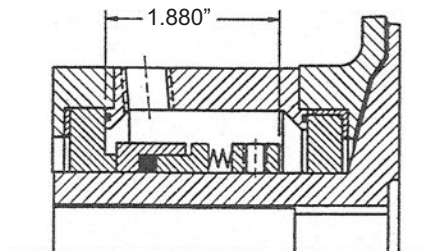

Durametallic Type "RO"
Internally Mounted

Figure 64 - Installed Standard Seals (length provided for aid of assembly)

Cartridge Seal Identification

The following pictorial list of cartridge seals is provided to assist in identifying some of the seals provided with the Model 200 centrifugal pumps. Use of these cartridges requires a cartridge seal adapter.

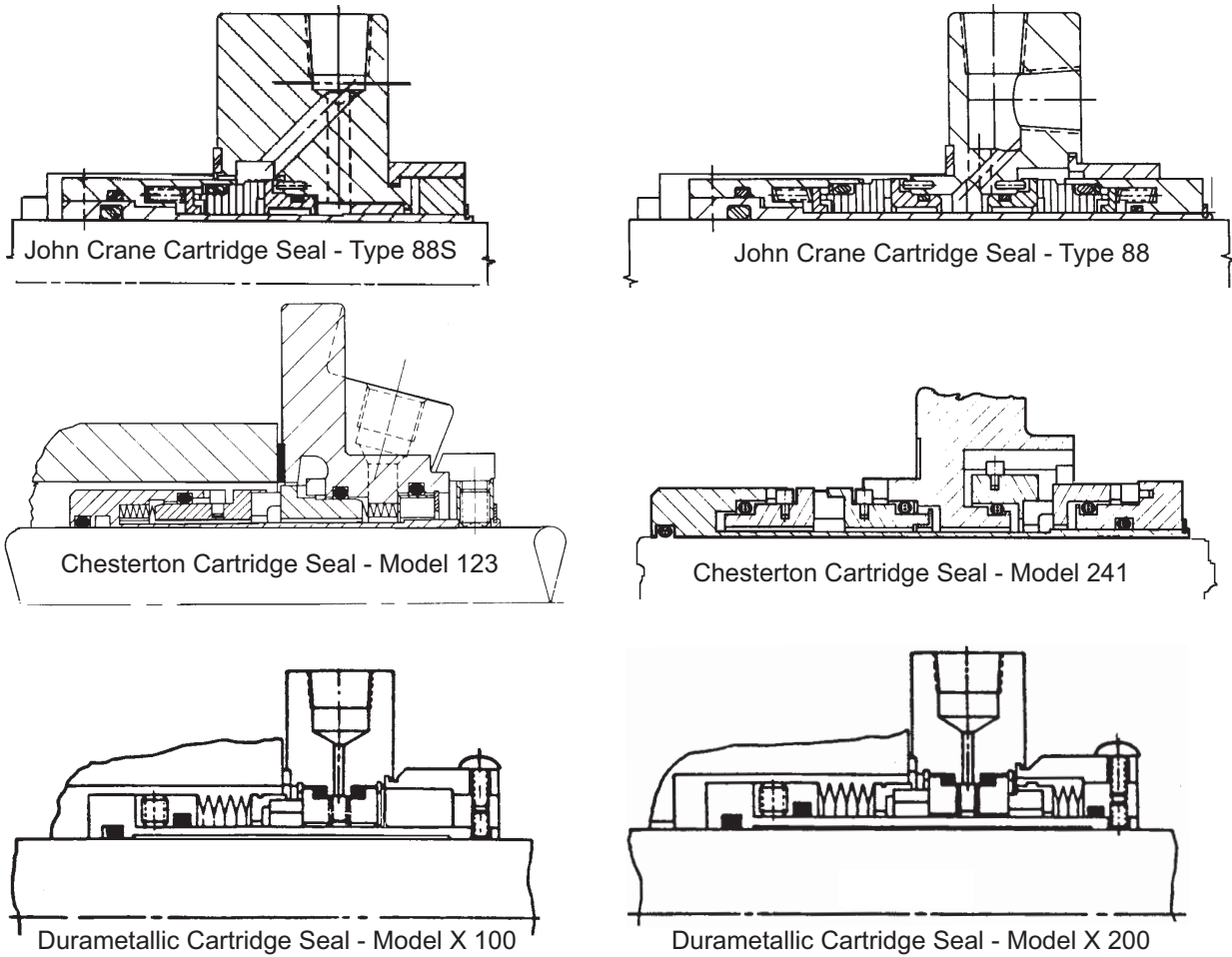

Figure 65 - Installed Cartridge Seals

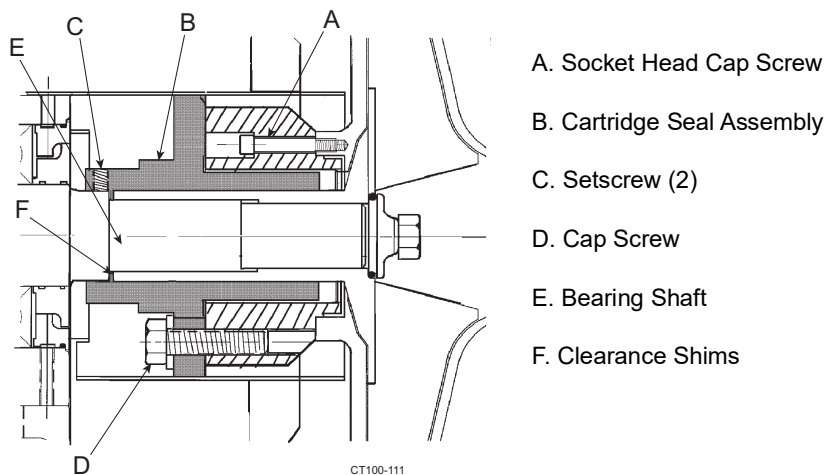
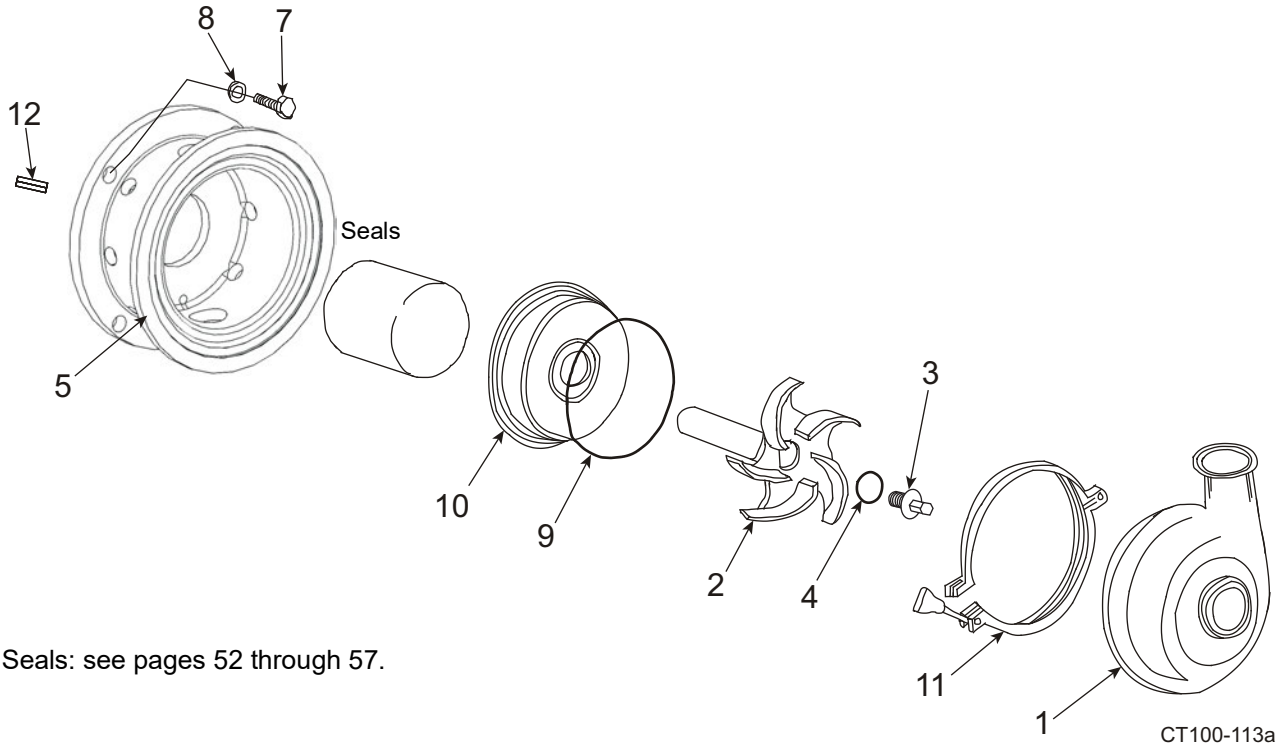

Figure 66 - Typical Cartridge Seal Installation

Parts Lists

2045 Pump Parts



Seals: see pages 52 through 57.

2045 Casing Parts

FITTING TYPE	SANITARY		NOTES
	1.5 x 1.5	2 x 1.5	
S-Line	CENTCASE00033	CENTCASE00034	
Bevel Seat	CENTCASE00035	CENTCASE00036	
I-Line; Female	CENTCASE00037	CENTCASE00038	
I-Line; Male	CENTCASE00039	CENTCASE00040	
Weld	CENTCASE00041	CENTCASE00042	
NPT; Male	CENTCASE00043	CENTCASE00044	1
NPT; Female	CENTCASE00045	CENTCASE00046	1
150 lb. Flange	CENTCASE00047	CENTCASE00048	1

PL5030-CH2

Notes:

1. These casings do not meet the requirements of 3-A Sanitary Standards.

2045 Pump Parts

ITEM NO.	DESCRIPTION	QTY. PER PUMP	PART NO.	NOTES
1	Casing (see 2045 Casing Parts List)	1	see prev. page	
2	Impeller, Full 4.5" Diameter	1	5-80X	1
3	Impeller Retainer Assembly	1	129-773X	3
	Assembly contains:			
	Impeller Retainer Nut, 2045	1	122456+	
	Stud, .375-16x1.25"LG 2A 18-8	1	123845+	
	Loctite® (not shown)	1	120723+	
* 4	Impeller O-Ring, FKM	1	V70214	
	Impeller O-Ring, EPDM	1	E70214	
	Impeller O-Ring, Silicone	1	S75214	
	Impeller O-Ring, FFKM	1	K70214	
	Impeller O-Ring, PTFE Encapsulated	1	T80214	
5	Adapter, 143JM - 184JM Frame, SS	1	122059+	2
7	3/8 - 16 x 3/4" Hex Screw	4	30-50	
8	3/8" Lockwasher	4	43-28	
* 9	Casing O-Ring, FKM	1	V70252	
	Casing O-Ring, EPDM	1	E70252	
	Casing O-Ring, Silicone	1	S75252	
	Casing O-Ring, FFKM	1	K70252	
	Casing O-Ring, PTFE Encapsulated	1	T80252	
10	Backplate	1	1-59X	
11	Casing Clamp	1	119-71	
12	Key - 3/16"	1	65-3	

PL5030-CH1

Notes:

- * Recommended Spare Parts - some available as kits for standard seals-see pages 52 through 57.
- 1. Trimmed impellers use the same part number; specify the diameter required in 1/8" increments on order.
- 2. Previously supplied as 2 pieces, an adapter and a seal guard; now a single piece.
- 3. Previously supplied as 1 piece; as of 11/1/04, now a stud and nut assembly, secured with Loctite®

2065LV - 2065 - 2065HV Pump Parts

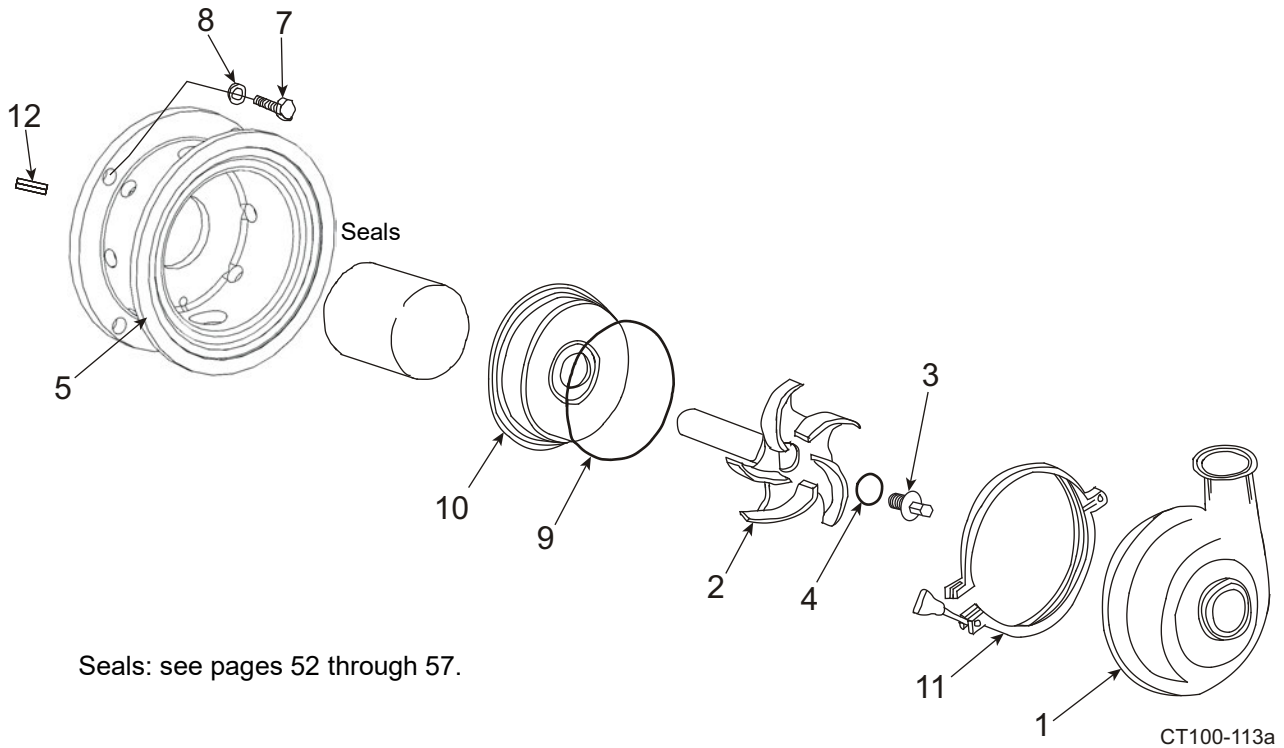

Seals: see pages 52 through 57.

2065LV - 2065 - 2065HV Casing Parts

FITTING TYPE	2065LV SANITARY			NOTES
	1.5 x 1.5	2 x 1.5	2.5 x 1.5	
S-Line	CENTCASE00049	CENTCASE00050	CENTCASE00051	
Bevel Seat	CENTCASE00054	CENTCASE00055	CENTCASE00056	
I-Line; Female	CENTCASE00061	CENTCASE00062	CENTCASE00063	
I-Line; Male	CENTCASE00066	CENTCASE00067	CENTCASE00068	
Weld	CENTCASE00071	CENTCASE00072	CENTCASE00073	
NPT; Male	CENTCASE00076	CENTCASE00077	CENTCASE00078	1
NPT; Female	CENTCASE00081	CENTCASE00082	CENTCASE00083	1
150 lb. Flange	CENTCASE00086	CENTCASE00087	CENTCASE00088	1

FITTING TYPE	2065 SANITARY	2065HV SANITARY	NOTES
	2.5 x 2	3 X 2	
S-Line	CENTCASE00052	CENTCASE00053	
Bevel Seat	CENTCASE00057	CENTCASE00058	
I-Line; Female	CENTCASE00064	CENTCASE00065	
I-Line; Male	CENTCASE00069	CENTCASE00070	
Weld	CENTCASE00074	CENTCASE00075	
NPT; Male	CENTCASE00079	CENTCASE00080	1
NPT; Female	CENTCASE00084	CENTCASE00085	1
150 lb. Flange	CENTCASE00089	CENTCASE00090	1

PL5030-CH4

Notes:

1. These casings do not meet the requirements of 3-A Sanitary Standards.

2065LV - 2065 - 2065HV Pump Parts

ITEM NO.	DESCRIPTION	QTY. PER PUMP	PART NO.	NOTES
1	Casing (see 2065LV-2065-2065HV Casing Parts List)	1	see prev. page	
2	2065LV Impeller, 6.5" Dia., 143-215JM, SM Bore	1	109256+	1
	2065LV Impeller, 6.5" Dia., 254-326JM, LG Bore	1	109258+	1
	2065 Impeller, 6.5" Dia., 143-215JM, SM Bore	1	109260+	1
	2065 Impeller, 6.5" Dia., 254-326JM, LG Bore	1	109262+	1
	2065HV Impeller, 6.5" Dia., 143-215JM, SM Bore	1	109264+	1
	2065HV Impeller, 6.5" Dia., 254-326JM, LG Bore	1	109266+	1
3	Impeller Retainer Assembly, 143-215JM, SM Bore	1	129-771X	3
	Assembly contains:			
	Impeller Retainer Nut, SM Bore	1	122453+	
	Stud, .375-16x1.25"LG 2A 18-8	1	123845+	
	Loctite® (not shown)	1	120723+	
	Impeller Retainer Assembly, 254-326JM, LG Bore	1	129-772X	3
	Assembly contains:			
	Impeller Retainer Nut, LG Bore	1	122454+	
* 4	Impeller O-Ring, FKM	1	V70220	
	Impeller O-Ring, EPDM	1	E70220	
	Impeller O-Ring, Silicone	1	S75220	
	Impeller O-Ring, FFKM	1	K70220	
	Impeller O-Ring, PTFE Encapsulated	1	T80220	
	5	Adapter, 143-184JM Frame, SS	1	122045+
Adapter, 213-215JM Frame, SS		1	122035+	2
Adapter, 254-256JM Frame, SS		1	121888+	2
Adapter, 284-326JM Frame, SS		1	122069+	2
7	3/8-16 x 1" Hex Screw, 143-184JM Frame	4	30-30	
	1/2-13 x 1-1/4" Hex Screw, 213-256JM Frame	4	30-36X	
	5/8-11 x 1-1/2" Hex Screw, 284-326JM Frame	4	30-105	
8	3/8" Lockwasher	4	43-28	
	1/2" Lockwasher	4	43-16	
	5/8" Lockwasher	4	43-33	
* 9	Casing O-Ring, FKM	1	V70439	
	Casing O-Ring, EPDM	1	E70439	
	Casing O-Ring, Silicone	1	S75439	
	Casing O-Ring, FFKM	1	K70439	
	Casing O-Ring, PTFE Encapsulated	1	T80439	
10	Backplate	1	1-60X	
11	Casing Clamp	1	119-70	
12	Key-3/16", 143-215JM, SM Bore	1	65-3	
	Key-1/4", 254-326JM, LG Bore	1	65-4	

PL5030-CH3

Notes:

* Recommended Spare Parts - some available as kits for standard seals-see pages 52 through 57.

1. Trimmed impellers use the same part number and price; specify the diameter required in 1/8" increments on order.
2. Previously supplied as 2 pieces: an adapter and a seal guard; now a single piece.
3. Previously supplied as 1 piece; as of 11/1/04, now a stud and nut assembly, secured with Loctite®

2075 Pump Parts

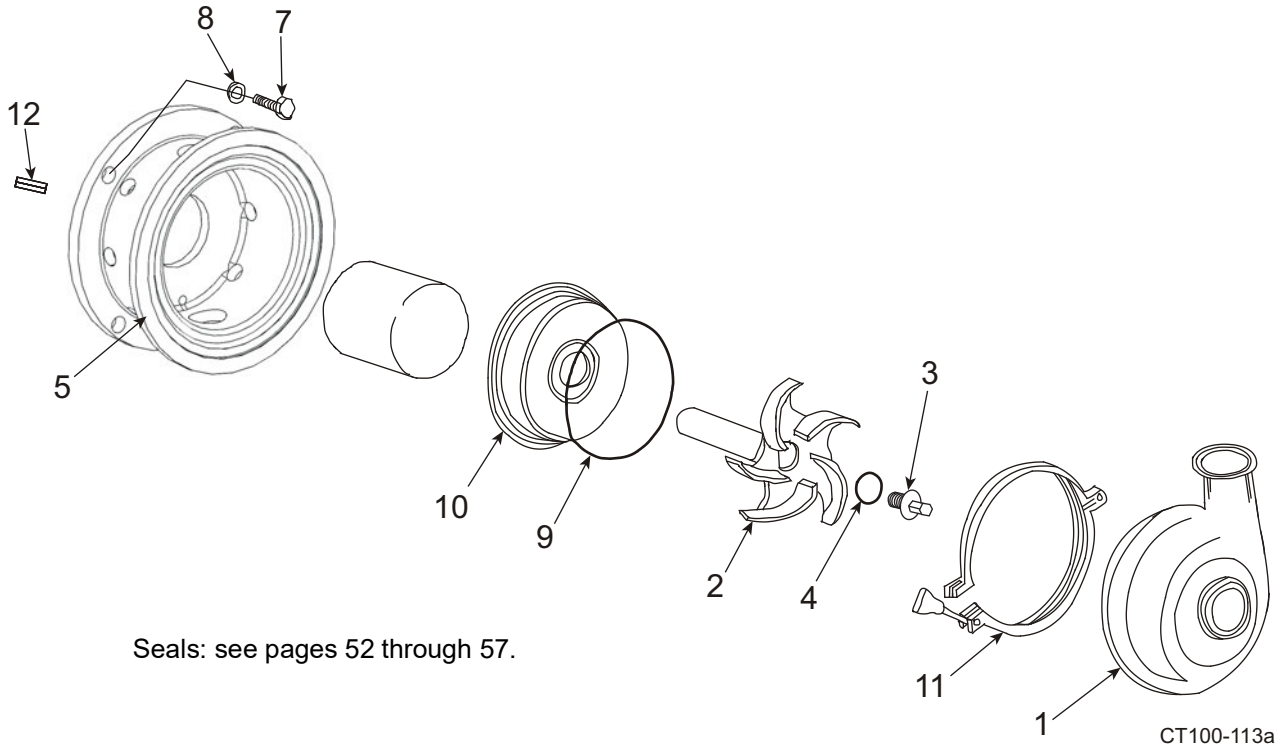

2075 Casing Parts

FITTING TYPE	SANITARY	NOTES
	3 x 1-1/2	
S-Line	CENTCASE00091	
Bevel Seat	CENTCASE00092	
I-Line; Female	CENTCASE00093	
I-Line; Male	CENTCASE00094	
Weld	CENTCASE00095	
NPT; Male	CENTCASE00096	1
NPT; Female	CENTCASE00097	1
150 lb. Flange	CENTCASE00098	1

PL5030-CH6

Notes:

- 1. These casings do not meet the requirements of 3-A Sanitary Standards.

2075 Pump Parts

ITEM NO.	DESCRIPTION	QTY. PER PUMP	PART NO.	NOTES
1	Casing (see 2075 Casing Parts List)	1		
2	2075 Impeller, 8.7" Dia., 143-215JM, SM Bore	1	109723+	1
	2075 Impeller, 8.7" Dia., 254-326JM, LG Bore	1	109741+	1
3	Impeller Retainer Assembly, 143-215JM, SM Bore	1	129-771X	3
	Assembly contains:			
	Impeller Retainer Nut, SM Bore	1	122453+	
	Stud, .375-16x1.25"LG 2A 18-8	1	123845+	
	Loctite® (not shown)	1	120723+	
	Impeller Retainer Assembly, 254-326JM, LG Bore	1	129-772X	3
	Assembly contains:			
	Impeller Retainer Nut, LG Bore	1	122454+	
	Stud, .50-13x1.50"LG 2A 18-8	1	123846+	
Loctite® (not shown)	1	120723+		
* 4	Impeller O-Ring, FKM	1	V70220	
	Impeller O-Ring, EPDM	1	E70220	
	Impeller O-Ring, Silicone	1	S75220	
	Impeller O-Ring, FFKM	1	K70220	
	Impeller O-Ring, PTFE Encapsulated	1	T80220	
5	Adapter, 143-184JM Frame, SS	1	122053+	2
	Adapter, 213-215JM Frame, SS	1	122055+	2
	Adapter, 254-256JM Frame, SS	1	122096+	2
	Adapter, 284-326JM Frame, SS	1	122057+	2
7	3/8-16 x 1" Hex Screw, 143-184JM Frame	4	30-30	
	1/2-13 x 1-1/4" Hex Screw, 213-256JM Frame	4	30-36X	
	5/8-11 x 1-1/2" Hex Screw, 284-326JM Frame	4	30-105	
8	3/8" Lockwasher	4	43-28	
	1/2" Lockwasher	4	43-16	
	5/8" Lockwasher	4	43-33	
* 9	Casing O-Ring, FKM	1	V70446	
	Casing O-Ring, EPDM	1	E70446	
	Casing O-Ring, Silicone	1	S75446	
	Casing O-Ring, FFKM	1	K70446	
	Casing O-Ring, PTFE Ecapsulated	1	T80446	
10	Backplate	1	1-61X	
11	Casing Clamp	1	119-69	
12	Key-3/16", 143-215JM, SM Bore	1	65-3	
	Key-1/4", 254-326JM, LG Bore	1	65-4	

PL5030-CH5

Notes:

- * Recommended Spare Parts - some available as kits for standard seals-see pages 52 through 57.
1. Trimmed impellers use the same part number and price; specify the diameter required in 1/8" increments on order.
 2. Previously supplied as 2 pieces: an adapter and a seal guard; now a single piece.
 3. Previously supplied as 1 piece; as of 11/1/04, now a stud and nut assembly, secured with Loctite®

2085LV - 2085 Pump Parts

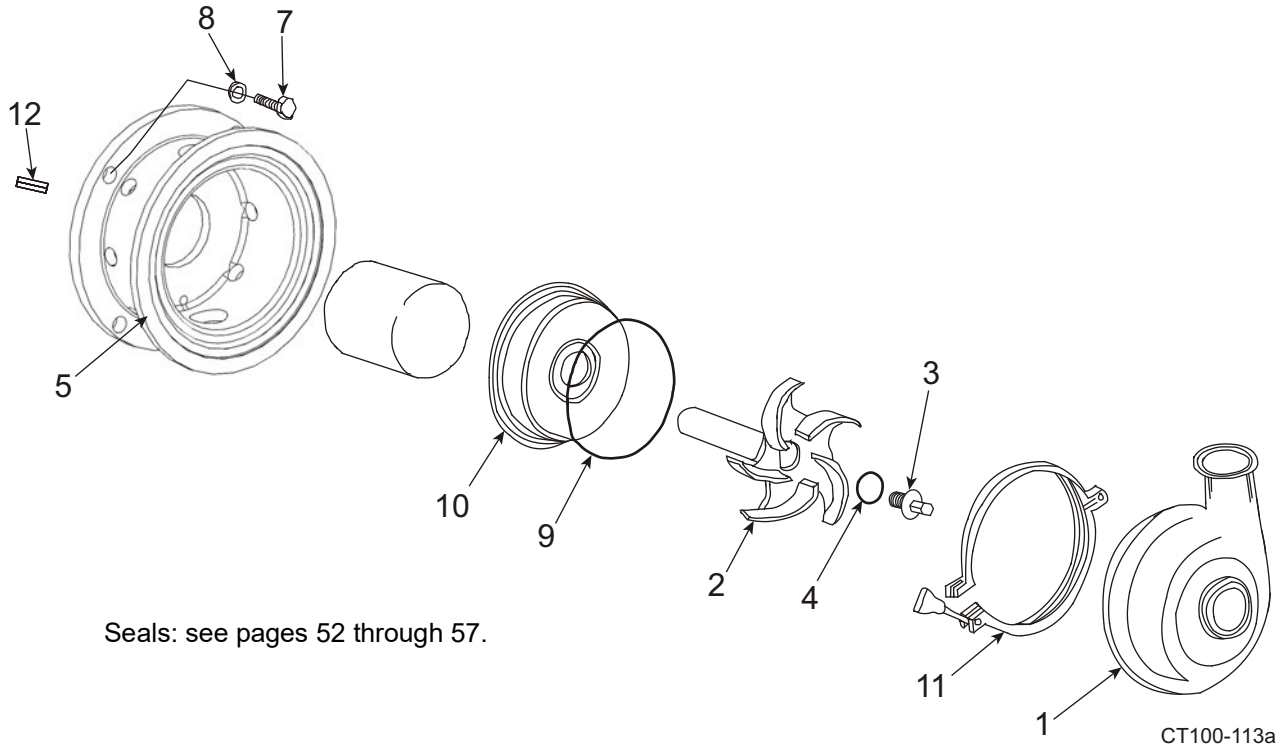

2085LV - 2085 Casing Parts

FITTING TYPE	2085LV SANITARY	2085 SANITARY		NOTES
	2 X 1.5	3 x 2.5	4 x 2.5	
S-Line	CENTCASE00099	CENTCASE00100	CENTCASE00101	
Bevel Seat	CENTCASE00102	CENTCASE00103	CENTCASE00104	
I-Line; Female	CENTCASE00105	CENTCASE00106	CENTCASE00107	
I-Line; Male	CENTCASE00108	CENTCASE00109	CENTCASE00110	
Weld	CENTCASE00111	CENTCASE00112	CENTCASE00113	
NPT; Male	CENTCASE00114	CENTCASE00115	CENTCASE00117	1
NPT; Female	CENTCASE00116	CENTCASE00118	CENTCASE00119	1
150 lb. Flange	CENTCASE00120	CENTCASE00121	CENTCASE00122	1

PL5030-CH8

Notes:

1. These casings do not meet the requirements of 3-A Sanitary Standards.

2085LV - 2085 Pump Parts

ITEM NO.	DESCRIPTION	QTY. PER PUMP	PART NO.	NOTES
1	Casing (see 2085LV-2085 Casing Parts List)	1		
2	2085LV Impeller, 8.7" Dia., 143-215JM, SM Bore	1	109723+	1
	2085LV Impeller, 8.7" Dia., 254-326JM, LG Bore	1	109741+	1
	2085 Impeller, 8.7" Dia., 143-215JM, SM Bore	1	109248+	1
	2085 Impeller, 8.7" Dia., 254-326JM, LG Bore	1	109249+	1
3	Impeller Retainer Assembly, 143-215JM, SM Bore	1	129-771X	3
	Assembly contains:			
	Impeller Retainer Nut, SM Bore	1	124453+	
	Stud, .375-16x1.25"LG 2A 18-8	1	123845+	
	Loctite® (not shown)	1	120723+	
	Impeller Retainer Assembly, 254-326JM, LG Bore	1	129-772X	3
	Assembly contains:			
	Impeller Retainer Nut, LG Bore	1	124454+	
	Stud, .50-13x1.50"LG 2A 18-8	1	123846+	
Loctite® (not shown)	1	120723+		
* 4	Impeller O-Ring, FKM	1	V70220	
	Impeller O-Ring, EPDM	1	E70220	
	Impeller O-Ring, Silicone	1	S75220	
	Impeller O-Ring, FFKM	1	K70220	
	Impeller O-Ring, PTFE Encapsulated	1	T80220	
5	Adapter, 143-184JM Frame, SS	1	122053+	2
	Adapter, 213-215JM Frame, SS	1	122055+	2
	Adapter, 254-256JM Frame, SS	1	122096+	2
	Adapter, 284-326JM Frame, SS	1	122057+	2
7	3/8-16 x 1" Hex Screw, 143-184JM Frame	4	30-30	
	1/2-13 x 1-1/4" Hex Screw, 213-256JM Frame	4	30-36X	
	5/8-11 x 1-1/2" Hex Screw, 284-326JM Frame	4	30-105	
8	3/8" Lockwasher	4	43-28	
	1/2" Lockwasher	4	43-16	
	5/8" Lockwasher	4	43-33	
* 9	Casing O-Ring, FKM	1	V70446	
	Casing O-Ring, EPDM	1	E70446	
	Casing O-Ring, Silicone	1	S75446	
	Casing O-Ring, FFKM	1	K70446	
	Casing O-Ring, PTFE Encapsulated	1	T80446	
10	Backplate	1	1-61X	
11	Casing Clamp	1	119-69	
12	Key-3/16", 143-215JM, SM Bore	1	65-3	
	Key-1/4", 254-326JM, LG Bore	1	65-4	

PL5030-CH7

Notes:

- * Recommended Spare Parts - some available as kits for standard seals-see pages 52 through 57.
- 1. Trimmed impellers use the same part number and price; specify the diameter required in 1/8" increments on order.
- 2. Previously supplied as 2 pieces: an adapter and a seal guard; now a single piece.
- 3. Previously supplied as 1 piece; as of 11/1/04, now a stud and nut assembly, secured with Loctite®

2105 Pump Parts

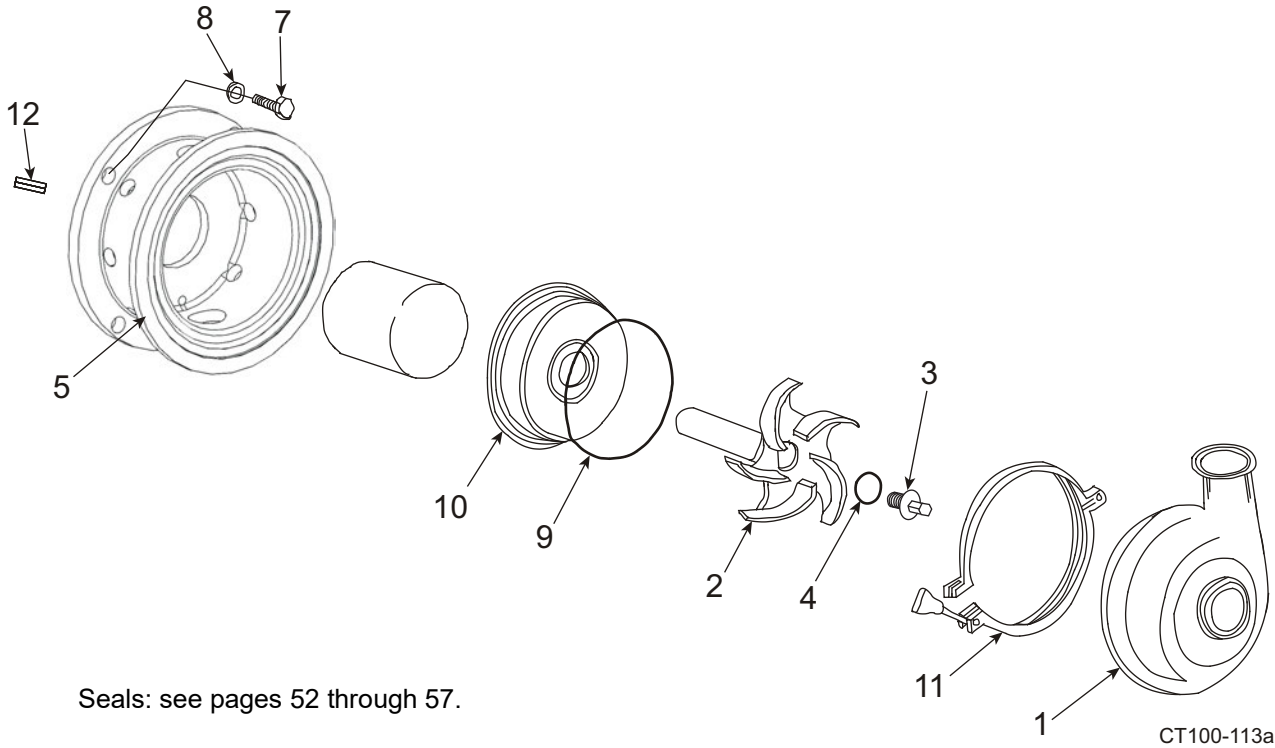

Seals: see pages 52 through 57.

2105 Casing Parts

FITTING TYPE	SANITARY		NOTES
	4 X 4	6 X 4	
S-Line	CENTCASE00123	CENTCASE00124	
Bevel Seat	CENTCASE00125	NA	
I-Line; Female	CENTCASE00126	CENTCASE00127	
I-Line; Male	CENTCASE00128	CENTCASE00129	
Weld	CENTCASE00130	CENTCASE00131	
NPT; Male	CENTCASE00132	CENTCASE00133	1
NPT; Female	CENTCASE00024	CENTCASE00134	1
150 lb. Flange	CENTCASE00135	CENTCASE00136	1

PL5030-CH10

Notes:

- 1. These casings do not meet the requirements of 3-A Sanitary Standards.

2105 Pump Parts

ITEM NO.	DESCRIPTION	QTY. PER PUMP	PART NO.	NOTES
1	Casing (see 2105 Casing Parts List)	1		
2	Impeller, 10.5" Dia., 184-215JM Frame SM Bore	1	5-72X	1
	Impeller, 10.5" Dia., 254-326JM Frame LG Bore	1	5-70X	1
3	Impeller Retainer Assembly, 143-215JM, SM Bore	1	129-771X	3
	Assembly contains:			
	Impeller Retainer Nut, SM Bore	1	124453+	
	Stud, .375-16x1.25"LG 2A 18-8	1	123845+	
	Loctite® (not shown)	1	120723+	
	Impeller Retainer Assembly, 254-326JM, LG Bore	1	129-772X	3
	Assembly contains:			
	Impeller Retainer Nut, LG Bore	1	124454+	
	Stud, .50-13x1.50"LG 2A 18-8	1	123846+	
Loctite® (not shown)	1	120723+		
4	Impeller O-Ring, FKM	1	V70220	
	Impeller O-Ring, EPDM	1	E70220	
	Impeller O-Ring, Silicone	1	S75220	
	Impeller O-Ring, FFKM	1	K70220	
	Impeller O-Ring, PTFE Encapsulated	1	T80220	
5	Adapter, 184JM Frame, SS	1	122059+	2
	Adapter, 213-215JM Frame, SS	1	122063+	2
	Adapter, 254-256JM Frame, SS	1	122065+	2
	Adapter, 284-326JM Frame, SS	1	122067+	2
7	3/8-16 x 1" Hex Screw, 184JM Frame	4	30-30	
	1/2-13 x 1-1/4" Hex Screw, 213-256JM Frame	4	30-36X	
	5/8-11 x 1-1/2" Hex Screw, 284-326JM Frame	4	30-105	
8	3/8" Lockwasher	4	43-28	
	1/2" Lockwasher	4	43-16	
	5/8" Lockwasher	4	43-33	
9	Casing O-Ring, FKM	1	V70450	
	Casing O-Ring, EPDM	1	E70450	
	Casing O-Ring, Silicone	1	S75450	
	Casing O-Ring, FFKM	1	K70450	
	Casing O-Ring, PTFE Encapsulated	1	T80450	
10	Backplate	1	1-29X	
11	Casing Clamp	1	119-223	
12	Key-3/16", 184-215JM, SM Bore	1	65-3	
	Key-1/4", 254-326JM, LG Bore	1	65-4	

PL5030-CH9

Notes:

- * Recommended Spare Parts - some available as kits for standard seals-see pages 52 through 57.
1. Trimmed impellers use the same part number and price; specify the diameter required in 1/8" increments on order.
 2. Previously supplied as 2 pieces: an adapter and a seal guard; now a single piece.
 3. Previously supplied as 1 piece; as of 11/1/04, now a stud and nut assembly, secured with Loctite®

Type 1 Seal Components and Common Parts

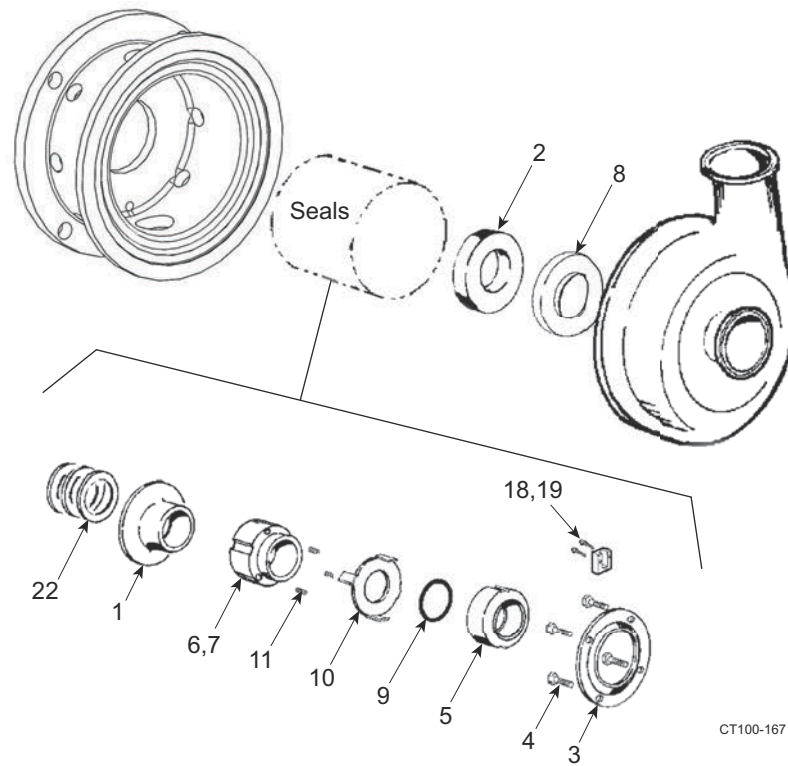

For shims, item 22, see "Motor Shaft Shims" on page 62.

Type 1 Seal Components and Common Parts

ITEM NO.	DESCRIPTION	QTY. PER PUMP	PART NO.	NOTES
1	Deflector	1	69-1	
* 2	Stationary Seal, Siliconized Graphite	1	23-17	
	Stationary Seal, Ceramic		23-17E	
	Stationary Seal, Silicon Carbide		23-17A	
	Stationary Seal, Sintered Silicon Carbide		23-17G	
	Stationary Seal, Tungsten Carbide		23-17F	2
	Stationary Seal, Silicon Carbide USP VI		23-17H	2
3	Stationary Seal Retainer	1	23-78	
4	1/4-20 x 1/2 Bolt	4	30-62	
* 5	Rotary Seal, Carbon	1	9-225A	
	Rotary Seal, Siliconized Graphite		9-225B	
	Rotary Seal, Silicon Carbide		9-225C	
	Rotary Seal, Tungsten Carbide		9-225F	
	Rotary Seal, Sintered Silicon Carbide		9-225G	
	Rotary Seal, Silicon Carbide USP VI		9-225H	2
	Rotary Seal, Carbon, USP VI		9-225D	2
6	1/4-20 x 3/8 Set Screw	2	30-178	
7	Spring Retainer	1	23-77	
* 8	L-Gasket, FKM	2	9-37	
	L-Gasket, EPDM		9-37E	
	L-Gasket, Silicone		9-37R	
	L-Gasket, FFKM		9-37K	
	L-Gasket, FKM USP Class VI		USP9-37V	2
	L-Gasket, EPDM USP Class VI		USP9-37E	2
	Flat Gasket, substitute, Gore-Tex®	2	20-278	1
	O-ring, PTFE Encaps. (used with 20-278)	2	T80041	1
* 9	Seal O-Ring, FKM	1	V70224	
	Seal O-Ring, EPDM		E70224	
	Seal O-Ring, Silicone		S75224	
	Seal O-Ring, FFKM		K70224	
	Seal O-Ring, FKM USP Class VI		USPV70224	2
	Seal O-Ring, EPDM USP Class VI		USPE70224	2
10	Washer, tabbed	1	43-87	
11	Spring	3	24-65	
18	Block, Water (For type 1 cascade)	1	134-2	
19	8-32 x 1/4 Screw (For type 1 cascade)	1	30-176	
20	1/4" Plastic Hose (For type 1 cascade, not shown)	12 (in.)	74-1	
21	1/4" Hose Fitting (For type 1 cascade, not shown)	1	78-18	
	Cascade Assembly (not shown)	1	334-2	

PL5030-CH11

Notes:

* Recommended spare parts

1. T80041 must be used in conjunction with 20-278 if 20-278 is selected. Assemble the flat gaskets (20-278) in the backplate. Assemble the stationary seal (item 2) with the encapsulated O-ring (T80041, not shown) and press it in.

2. USP Class VI seals can only be used with Class VI elastomers.

For shims, item 22, see "Motor Shaft Shims" on page 62.

For seal kits, see page 56.

Type 4 Seal Components and Common Parts

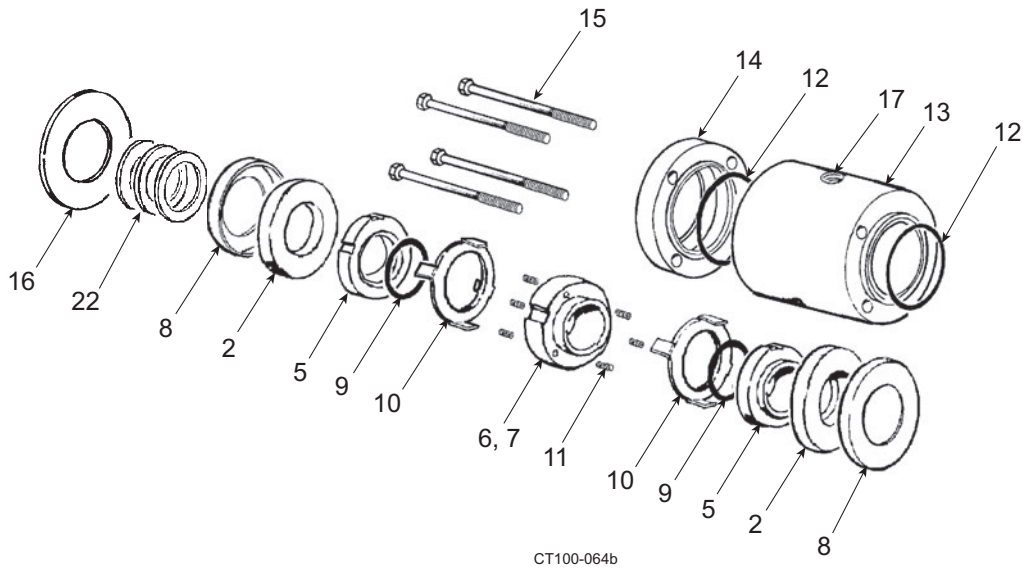

For shims, item 22, see "Motor Shaft Shims" on page 62.

Type 4 Seal Components and Common Parts

ITEM NO.	DESCRIPTION	QTY. PER PUMP	PART NO.	NOTES	Qty needed to convert Type 1 to Type 4
2	Stationary Seal, Siliconized Graphite	1	23-17		1
	Stationary Seal, Ceramic		23-17E		
	Stationary Seal, Silicon Carbide		23-17A		
	Stationary Seal, Sintered Silicon Carbide		23-17G		
	Stationary Seal, Tungsten Carbide		23-17F		
	Stationary Seal, Silicon Carbide USP Class VI		23-17H	2	
5	Rotary Seal, Carbon	1	9-225A		1
	Rotary Seal, Siliconized Graphite		9-225B		
	Rotary Seal, Silicon Carbide		9-225C		
	Rotary Seal, Tungsten Carbide		9-225F		
	Rotary Seal, Sintered Silicon Carbide		9-225G		
	Rotary Seal, Silicon Carbide USP Class VI		9-225H	2	
	Rotary Seal, Carbon, USP Class VI		9-225D	2	
6	1/4-20 x 3/8 Set Screw	2	30-178		
7	Spring Retainer	1	23-77		
8	L-Gasket, FKM	2	9-37		1
	L-Gasket, EPDM		9-37E		
	L-Gasket, Silicone		9-37R		
	L-Gasket, FFKM		9-37K		
	L-Gasket, FKM USP Class VI		USP9-37V	2	
	L-Gasket, EPDM USP Class VI		USP9-37E	2	
	Flat Gasket, substitute, Gore-Tex®	2	20-278	1	
	O-ring, PTFE Encaps. (used with 20-278)	2	T80041	1	
9	Seal O-Ring, FKM	2	V70224		1
	Seal O-Ring, EPDM		E70224		
	Seal O-Ring, Silicone		S75224		
	Seal O-Ring, FFKM		K70224		
	Seal O-Ring, FKM USP Class VI		USPV70224	2	
	Seal O-Ring, EPDM USP Class VI		USPE70224	2	
10	Washer, tabbed	2	43-87		1
11	Spring	6	24-65		
12	O-Ring, Housing, FKM	2	V70039		2
13	Housing, Seal	1	23-80		1
14	Retainer, Seal	1	23-79		1
15	1/4-20 x 3 Cap Screw	4	30-175		4
16	Deflector, 143-215JM	1	69-4		
	Deflector, 254-326JM	1	69-1		
17	1/4" NPT Plug	2	78-155		1

PL5030-CH12

Notes:

* Recommended spare parts

- T80041 must be used in conjunction with 20-278 if 20-278 is selected. Assemble the flat gaskets (20-278) in the backplate. Assemble the stationary seal (item 2) with the encapsulated O-ring (T80041, not shown) and press it in.
- USP Class VI seals can only be used with Class VI elastomers.
- To convert a Type 1 to a Type 4 seal, you will need: items 2, 5, 8, 9, 10, 11, 12, 13, 14, 15, and 17 in the quantities listed in the "Qty needed to convert Type 1 to Type 4" column.

For shims, item 22, see "Motor Shaft Shims" on page 62.

For seal kits, see page 57.

Type 1 Seal Kits

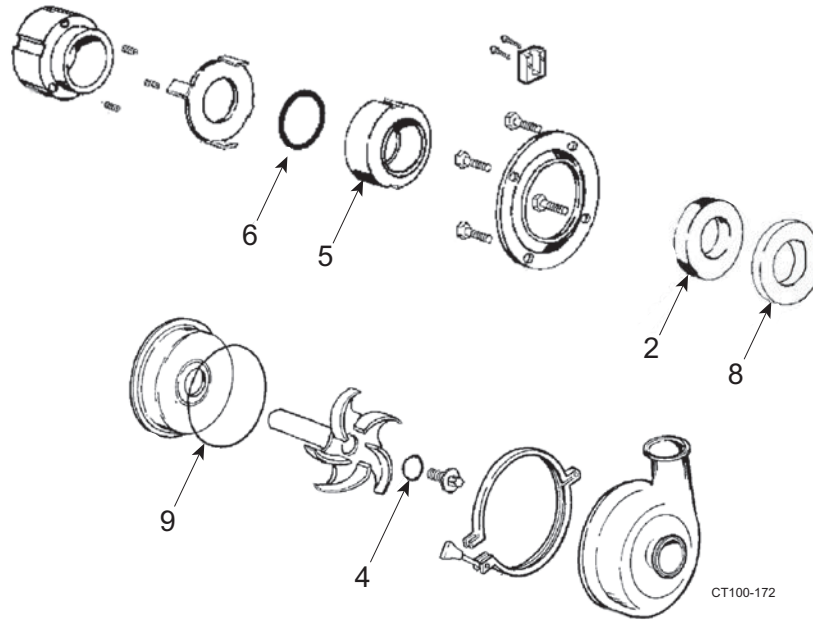

CT100-172

ITEM NO.	DESCRIPTION	QTY.	2045	2065LV 2065 2065HV	2075	2085LV 2085	2105
2	Stationary Seal, Siliconized Graphite	1	23-17	23-17	23-17	23-17	23-17
4	Impeller Retainer O-Ring, FKM	1	V70214	V70220	V70220	V70220	V70220
	Impeller Retainer O-Ring, EPDM		E70214	E70220	E70220	E70220	E70220
	Impeller Retainer O-Ring, Silicone		S75214	S75220	S75220	S75220	S75220
5	Rotary Seal, Carbon	1	9-225A	9-225A	9-225A	9-225A	9-225A
6	Seal O-Ring, FKM	1	V70224	V70224	V70224	V70224	V70224
	Seal O-Ring, EPDM		E70224	E70224	E70224	E70224	E70224
	Seal O-Ring, Silicone		S75224	S75224	S75224	S75224	S75224
8	L-Gasket, FKM	1	9-37	9-37	9-37	9-37	9-37
	L-Gasket, EPDM		9-37E	9-37E	9-37E	9-37E	9-37E
	L-Gasket, Silicone		9-37R	9-37R	9-37R	9-37R	9-37R
9	Casing O-Ring, FKM	1	V70252	V70439	V70446	V70446	V70450
	Casing O-Ring, EPDM		E70252	E70439	E70446	E70446	E70450
	Casing O-Ring, Silicone		S75252	S75439	S75446	S75446	S75450
Basic Seal Kit, contains items 4, 5, 6, 9 above	FKM		309-241	309-242	309-243	309-243	309-244
	EPDM		309-241E	309-242E	309-243E	309-243E	309-244E
	Silicone		309-241R	309-242R	309-243R	309-243R	309-244R
Complete Seal Kit, contains all items above	FKM		309-245	309-246	309-247	309-247	309-248
	EPDM		309-245E	309-246E	309-247E	309-247E	309-248E
	Silicone		309-245R	309-246R	309-247R	309-247R	309-248R

PL5030-CH14

Type 4 Seal Kits

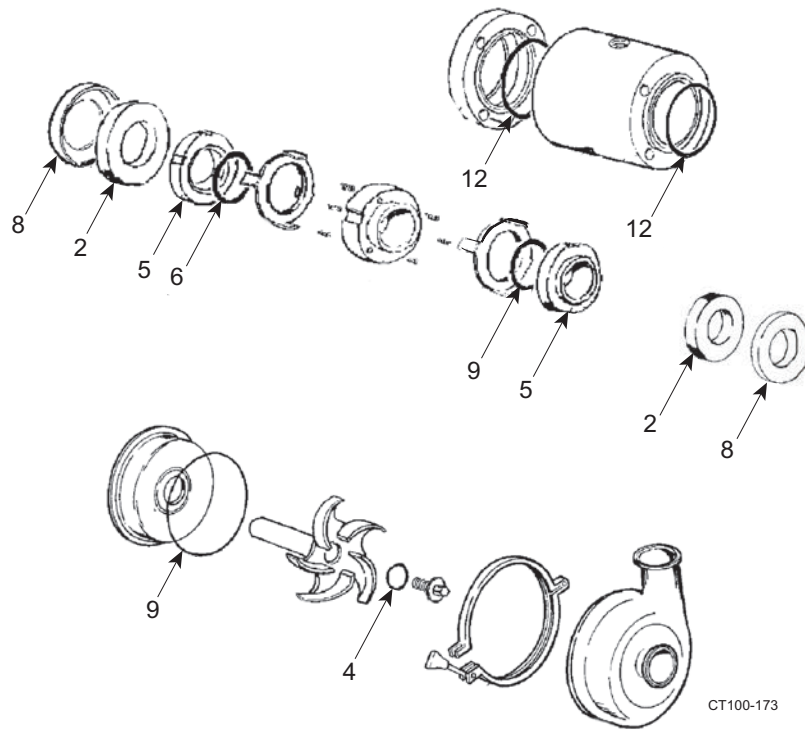

CT100-173

ITEM NO.	DESCRIPTION	QTY.	2045	2065LV 2065 2065HV	2075	2085LV 2085	2105
2	Stationary Seal, Siliconized Graphite	2	23-17	23-17	23-17	23-17	23-17
4	Impeller Retainer O-Ring, FKM	1	V70214	V70220	V70220	V70220	V70220
	Impeller Retainer O-Ring, EPDM		E70214	E70220	E70220	E70220	E70220
	Impeller Retainer O-Ring, Silicone		S75214	S75220	S75220	S75220	S75220
5	Rotary Seal, Carbon	2	9-225A	9-225A	9-225A	9-225A	9-225A
6	Seal O-Ring, FKM	2	V70224	V70224	V70224	V70224	V70224
	Seal O-Ring, EPDM		E70224	E70224	E70224	E70224	E70224
	Seal O-Ring, Silicone		S75224	S75224	S75224	S75224	S75224
8	L-Gasket, FKM	2	9-37	9-37	9-37	9-37	9-37
	L-Gasket, EPDM		9-37E	9-37E	9-37E	9-37E	9-37E
	L-Gasket, Silicone		9-37R	9-37R	9-37R	9-37R	9-37R
9	Casing O-Ring, FKM	1	V70252	V70439	V70446	V70446	V70450
	Casing O-Ring, EPDM		E70252	E70439	E70446	E70446	E70450
	Casing O-Ring, Silicone		S75252	S75439	S75446	S75446	S75450
12	Seal Housing O-Ring, FKM	2	V70039	V70039	V70039	V70039	V70039
	Seal Housing O-Ring, EPDM		E70039	E70039	E70039	E70039	E70039
	Seal Housing O-Ring, Silicone		S75039	S75039	S75039	S75039	S75039
Basic Seal Kit, contains items 4, 5, 6, 9, 12 above	FKM		309-249	309-250	309-251	309-251	309-252
	EPDM		309-249E	309-250E	309-251E	309-251E	309-252E
	Silicone		309-249R	309-250R	309-251R	309-251R	309-252R
Complete Seal Kit, contains all items above	FKM		309-253	309-254	309-255	309-255	309-256
	EPDM		309-253E	309-254E	309-255E	309-255E	309-256E
	Silicone		309-253R	309-254R	309-255R	309-255R	309-256R

PL5030-CH16

Style "C" Small Bore Pedestal Mount Parts

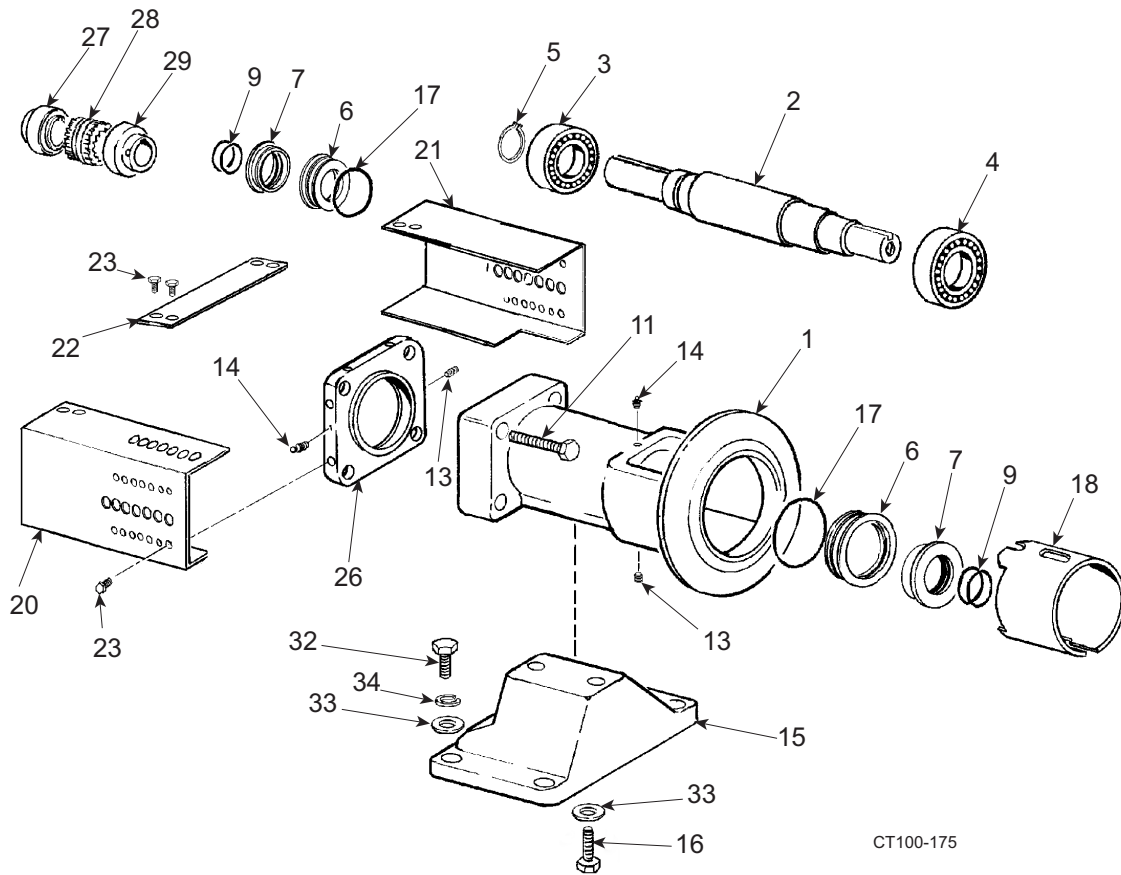

CT100-175

SMALL BORE PEDESTAL FOR:
MP2045 FOR MOTOR FRAME SIZE UP TO 215JM
MP2065LV FOR MOTOR FRAME SIZE UP TO 215T
MP2065 FOR MOTOR FRAME SIZE UP TO 215T
MP2065HV FOR MOTOR FRAME SIZE UP TO 215T
MP2085LV FOR MOTOR FRAME SIZE UP TO 215T
MP2085 FOR MOTOR FRAME SIZE UP TO 215T

Style "C" Small Bore Pedestal Mount Parts

ITEM NO.	DESCRIPTION	QTY. PER PUMP	PART NO.	NOTES
1	Bearing Housing, 2045, painted blue	1	131482+	
	Bearing Housing, 2065, painted blue	1	141027+	
	Bearing Housing, 2075 - 2085, painted blue	1	141028+	
2	Shaft	1	62-528X	
* 3	Rear Bearing	1	23-101	
* 4	Front Bearing	1	23-100	
* 5	Retaining Ring	1	43-139	
6	Seal, Outer	2	23-90	
7	Seal, Inner	1	23-89	
* 9	O-Ring, Inner	2	N70031	
11	1/2-13 x 2 HHCS	4	30-138X	
13	1/4-20 x 3/8" SHSS	2	30-178	
14	Grease Fitting	2	BD0092000	
15	Stand, painted blue	1	141029+	
16	1/2-13 x 1" HHCS	2	30-78X	
* 17	O-Ring, Outer	2	N70041	
18	Seal Guard, 2045	1	70-32	
	Seal Guard, 2065 / 2085, Small Bore	1	70-33	
20	Cover Coupling, L.H.	1	70-29	
21	Cover Coupling, R.H.	1	70-30	
22	Brace, Cover Coupling	1	2-251	
23	1/4-20 x 1/2" HHCS	8	30-62	
26	End Cap Housing, Small Bore, painted blue	1	141030+	
27	56 Frame Coupling Half .625W	1	11-37	
	143T-145T Frame Coupling Half .875" 5S	1	11-101	
	182T-184T Frame Coupling Half 1.125" 5S	1	11-102	
	213T-215T Frame Coupling Half 1.375" 6S	1	11-103	
	254T-256T Frame Coupling Half 1.625" 7S	1	11-41	
28	56 Frame Coupling Sleeve 4J	1	11-29	
	143T-184T Frame Coupling Sleeve 5JE	1	11-30	
	213T-215T Frame Coupling Sleeve 6JE	1	11-31	
	254T-256T Frame Coupling Sleeve 7JE	1	11-32	
29	56 Frame Coupling Half 1.0" 4J	1	11-95	
	143T-184T Frame Coupling Half 1.0" 5S	1	11-94	
	213T-215T Frame Coupling Half 1.0" 6S	1	11-96	
	254T-256T Frame Coupling Half 1.0" 7S	1	11-97	
32	1/2-13 x 1-1/2" HHCS	4	30-103	
33	1/2" Washer	6	43-31	
34	1/2" Lockwasher	4	43-16	

PL5030-CH17

Notes:

* Recommended spare part

Style “C” Large Bore Pedestal Mount Parts

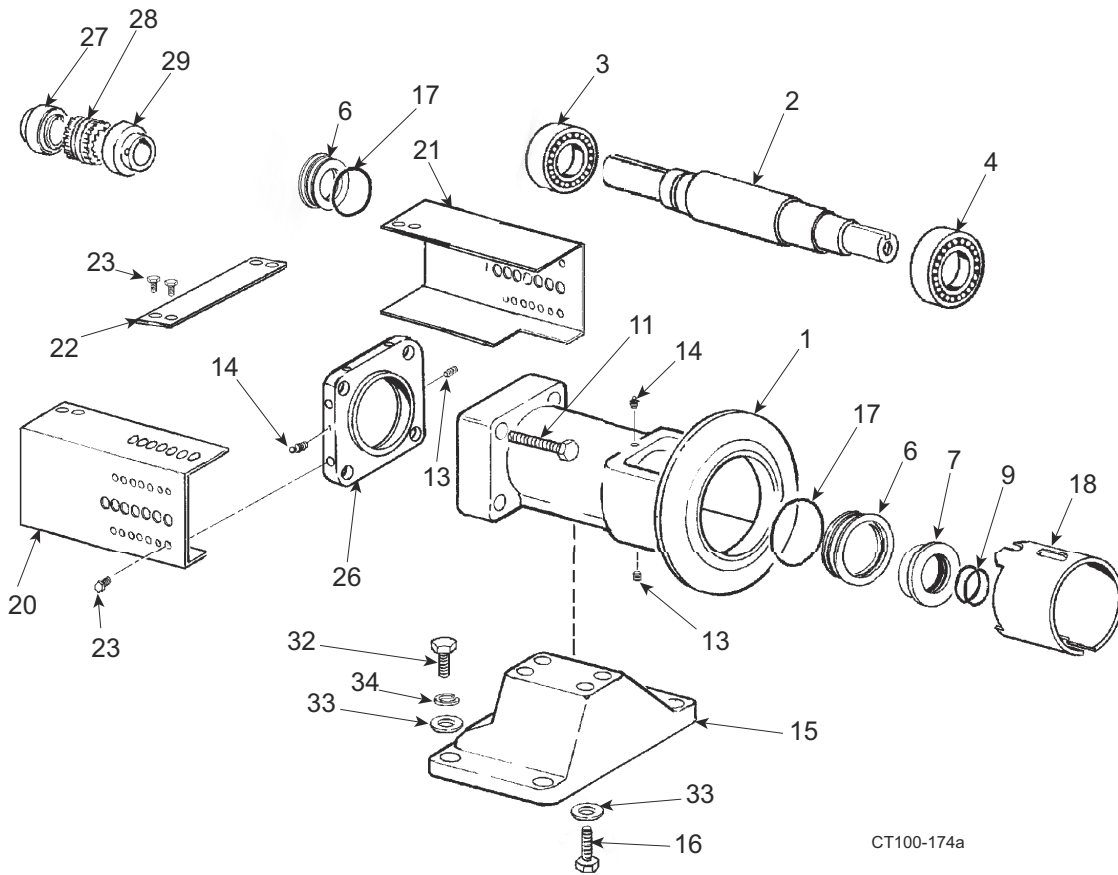

LARGE BORE PEDESTAL FOR:
MP2065 FOR MOTOR FRAME SIZE 254T THROUGH 365T
MP2065HV FOR MOTOR FRAME SIZE 254T THROUGH 365T
MP2085LV FOR MOTOR FRAME SIZE 254T THROUGH 365T
MP2085 FOR MOTOR FRAME SIZE 254T THROUGH 365T
MP2105 FOR MOTOR FRAME SIZE 254T THROUGH 365T

Style "C" Large Bore Pedestal Mount Parts

ITEM NO.	DESCRIPTION	QTY. PER PUMP	PART NO.	NOTES
1	Bearing Housing, 2065, painted blue	1	141033+	
	Bearing Housing, 2075 - 2085, painted blue	1	141034+	
	Bearing Housing, 2105, painted blue	1	141035+	
2	Shaft	1	126985+	
* 3	Rear Bearing	1	23-98	
* 4	Front Bearing	1	CD0036300	
6	Seal, Outer	2	23-95	
7	Seal, Inner	1	23-93	
* 9	O-Ring, Buna N, Inner	2	N70033	
11	1/2-13 x 3-1/4" HHCS	4	30-221X	
13	1/4-20 x 3/8" SHSS	2	30-178	
14	Grease Fitting	2	BD0092000	
15	Stand, painted blue	1	141032+	
16	1/2-13 x 1-1/4" HHCS	4	30-36X	
* 17	O-Ring, Buna N, Outer	2	N70045	
18	Seal Guard, 2065 / 2085	1	70-33	
	Seal Guard, 2105	1	70-37	
20	Cover Coupling, L.H.	1	70-35	
21	Cover Coupling, R.H.	1	70-36	
22	Brace, Cover Coupling	1	2-252	
23	1/4-20 x 1/2" HHCS	8	30-62	
26	End Cap Housing, Large Bore, painted blue	1	141031+	
27	213T-215T Frame Coupling Half 1.375" 6S	1	11-103	
	254T-256T Frame Coupling Half 1.625" 7S	1	11-41	
	284T-286T Frame Coupling Half 1.875" 7S	1	11-105	
	324T-326T Frame Coupling Half 2.125" 8S	1	11-106	
	364T-365T Frame Coupling Half 2.375" 8S	1	11-107	
28	213T-215T Frame Coupling Sleeve 6JE	1	11-31	
	254T-286T Frame Coupling Sleeve 7JE	1	11-32	
	324T-326T Frame Coupling Sleeve 8JE	1	11-33	
	364T-365T Frame Coupling Sleeve 8H	1	11-108	
29	213T-215T Coupling Half 1.250" 6S	1	11-98	
	254T-286T Coupling Half 1.250" 7S	1	11-99	
	324T-365T Coupling Half 1.250" 8S	1	11-100	
32	1/2-13 x 1-1/2" HHCS	4	30-103X	
33	1/2" Washer	4	43-31	
34	1/2" Lockwasher	4	43-16	

PL5030-CH18

Notes:

* Recommended spare part

Motor Mounts

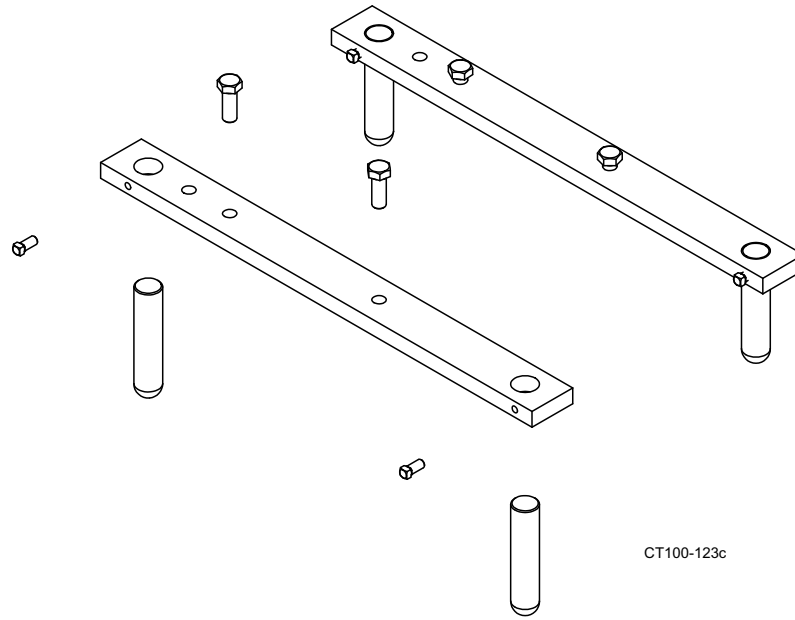

Description	Part Number
LEG KIT, NEMA 56C	114365+
LEG KIT, NEMA 143/145	110256+
LEG KIT, NEMA 182/184	110255+
LEG KIT, NEMA 213/215	110254+
LEG KIT, NEMA 254/256	110253+
LEG KIT, NEMA 284/286	110252+
LEG KIT, NEMA 324/326	110251+
LEG KIT, NEMA 364	110251A

PL5050-CH14

Motor Shaft Shims

NEMA FRAME SIZE	MOTOR SHAFT SHIM DIMENSIONS	PART #	QTY.
142 - 215	1.730" x 1.031" x 0.005"	35-1	AS REQUIRED
	1.730" x 1.031" x 0.010"	35-2	
	1.730" x 1.031" x 0.020"	35-3	
254 - 326	1.730" x 1.405" x 0.005"	35-4	AS REQUIRED
	1.730" x 1.405" x 0.010"	35-5	
	1.730" x 1.405" x 0.020"	35-6	

PL5030-CH27

Troubleshooting

PROBLEM	POSSIBLE CAUSE	SUGGESTED ACTION
Not Enough Liquid Delivered	Pump not primed	Prime pump. Install a priming system if possible.
	Suction or discharge plugged or closed	Open suction. If plugged, shut down pump and remove blockage.
	Air leak in supply or at seal area	Check system for air leaks and repair as necessary. Replace seals if required.
	Wrong direction of rotation	Adjust motor electrical wiring to correct rotation.
	Discharge head too high	Lower discharge head until pump can move material without turning to freely, causing overload.
	Suction lift too high	Lower pump in system until the pump is easily supplied with material.
	Speed too slow (low voltage, wrong frequency, wrong motor)	Adjust voltage and frequency. Change motor if necessary.
	Excessive air in material	Adjust system to remove excess air from material before it reaches the pump.
	Insufficient NPSH (Net Positive Suction Head) available	Adjust system to provide correct NPSH.
	Impeller diameter too small for duty	Contact your SPX FLOW Customer service representative for sizing information. 1-800-252-5200 or 262-728-1900
Not Enough Pressure	Air leak in supply or at seal area	Check system for air leaks and repair as necessary. Replace seals if required.
	Wrong direction of rotation	Adjust motor electrical wiring to correct rotation.
	Speed too slow (low voltage, wrong frequency, wrong motor)	Adjust voltage and frequency. Change motor if necessary.
	Excessive air in material	Adjust system to remove excess air from material before it reaches the pump.
	Impeller diameter too small for duty	Contact your SPX FLOW Customer service representative for sizing information. 1-800-252-5200 or 262-728-1900
Motor Overload	Faulty electrical connections	Check wiring and repair/replace as necessary.
	Unrestricted discharge resulting in too high a flow rate	Add discharge restriction to lower flow rate.
	Impeller interference	Disassemble pump and inspect for damage. Remove interference if still present. Replace worn/damaged parts.
	Seal binding	Disassemble pump and inspect for damage. Check for material crystallization on seals.
	Discharge head too low allowing pump to deliver too much liquid	Raise discharge head until pump achieves proper resistance to flow.

PROBLEM	POSSIBLE CAUSE	SUGGESTED ACTION
Motor Overload	Liquid heavier or more viscous than rating	Contact your SPX FLOW Customer service representative for sizing information. 1-800-252-5200 or 262-728-1900
	Overload heaters too small for motor	Inspect and replace as necessary.
	Electrical supply, voltage, frequency, incorrect	Adjust voltage and frequency. Change motor if necessary.
	Impeller diameter too large for duty	Contact your SPX FLOW Customer service representative for sizing information. 1-800-252-5200 or 262-728-1900
	Defective motor	Replace motor.
Vibration/Noise	Pump not level	Make sure all legs are touching the floor. Level pump.
	Piping not supported	Support all piping as described in the installation section.
	Starved suction/Supply line blocked	Shut down pump and remove blockage.
	Foreign material in pump	Disassemble pump, remove all foreign material and inspect for damage. Replace worn/damaged parts.
	Starved suction/Insufficient NPSH (Net Positive Suction Head) available	Adjust system to provide correct NPSH.
	Impeller hub/impeller shaft worn	Disassemble pump and inspect for damage. Replace worn parts.
	Impeller shaft loose or bent	Disassemble pump and inspect for damage.
	Impeller out of balance	Disassemble pump and inspect for damage. Replace impeller.
	Motor bearings worn	Disassemble motor and inspect for damage. Replace worn parts.
	Starved suction/supply line too long	Shorten system supply line.
	Starved suction/supply line too small	Install larger supply lines.
	Excessive air in material	Adjust system to remove excess air from material before it reaches the pump.
	Rapid Seal Wear	Incorrect impeller shaft location; excessive spring loading
Water hammer		Adjust system to reduce air in system and sudden starts or stops in flow.
Impeller shaft loose or bent		Disassemble pump and inspect for damage. Replace worn/damaged parts.
Abrasive product		Contact your SPX FLOW Customer service representative for sizing information. 1-800-252-5200 or 262-728-1900
Prolonged “dry” running		Adjust process to insure pump has a continual fresh supply of product during operation.
Abrasive solids (unfiltered) in flush water supplied to seal		Use only filtered water in seal flush system.

PROBLEM	POSSIBLE CAUSE	SUGGESTED ACTION
Seal Leaks	Gasket damaged or worn	Disassemble pump and inspect for damage.
	Seal not installed correctly	Disassemble pump and inspect seal for damage (replace if necessary). Install seal correctly and assemble pump.
	Carbon seal worn or damaged	Disassemble pump and inspect seal for damage (replace if necessary).
	Inlet/Outlet connection loose or no gasket	Inspect Inlet/outlet connection for gasket and tighten connection.
	Casing clamp loose	Tighten clamp.

Notes

200 Series

CENTRIFUGAL PUMP

SPXFLOW

Provided by:



SPX FLOW, INC.

611 Sugar Creek Road

Delavan, WI 53115

P: (262) 728-1900 or (800) 252-5200

F: (262) 728-4904 or (800) 252-5012

E: wcb@spxflow.com

SPX FLOW, Inc. reserves the right to incorporate our latest design and material changes without notice or obligation.

Design features, materials of construction and dimensional data, as described in this bulletin, are provided for your information only and should not be relied upon unless confirmed in writing.

Please contact your local sales representative for product availability in your region. For more information visit www.spxflow.com.

The green ">" is a trademark of SPX FLOW, Inc..

ISSUED: 12/2018

COPYRIGHT © 2018 SPX FLOW, Inc.